

# Broward Complete Streets Guidelines



Providing Guidance for Developing Safer  
and Healthier Streets Accommodating **ALL** Users





## Broward Attribution Statement

The *Broward Complete Streets Guidelines* represent six months of work to transform the 2011 *Los Angeles County Model Design Manual for Living Streets* into a customized document for use by all of Broward's local jurisdictions.

This work was made possible through a Centers for Disease Control and Prevention (CDC) grant, the Transforming Our Community's Health (TOUCH) Initiative, administered by the Broward Regional Health Planning Council (BRHPC). To help execute this project, Urban Health Partnerships, a South Florida not-for-profit organization, partnered with the Broward Metropolitan Planning Organization (MPO) and the Smart Growth Partnership. Efforts were guided with the assistance of the Broward MPO's Broward Complete Streets Technical Advisory Committee.



Customization of the *Broward Complete Streets Guidelines* to reflect local conditions, Florida State Statutes, Florida design criteria, and Broward County standards was conducted by:



*This publication was supported by the Cooperative Agreement Award Number U58DP003661-01 from the Centers for Disease Control and Prevention. Its contents are solely the responsibility of the authors and do not necessarily reflect the official views of the Centers for Disease Control and Prevention.*

## ATTRIBUTION STATEMENT

This manual is made possible by funding from the Department of Health and Human Services through the Los Angeles County Department of Public Health.

The sponsors include the following groups:



**UCLA** Luskin School *of* Public Affairs  

---

Luskin Center for Innovation

With support from:

**UCLA** Luskin School *of* Public Affairs  

---

Lewis Center

**UCLA** Luskin School *of* Public Affairs  

---

Institute of Transportation Studies

Creation of the manual was managed by:





## TABLE OF CONTENTS

TABLE OF CONTENTS.....	i
BROWARD ACKNOWLEDGEMENTS.....	ii
LOS ANGELES ACKNOWLEDGEMENTS .....	iv
RIGHT TO USE THIS MANUAL .....	ix
INDEX TABLE .....	x

<b>CHAPTER 1.</b>	<b>INTRODUCTION</b>
<b>CHAPTER 2.</b>	<b>VISION, GOALS, POLICIES, AND BENCHMARKS</b>
<b>CHAPTER 3.</b>	<b>COMMUNITY ENGAGEMENT FOR STREET DESIGN</b>
<b>CHAPTER 4.</b>	<b>STREET NETWORKS AND CLASSIFICATIONS</b>
<b>CHAPTER 5.</b>	<b>TRAVELED WAY DESIGN</b>
<b>CHAPTER 6.</b>	<b>INTERSECTION DESIGN</b>
<b>CHAPTER 7.</b>	<b>UNIVERSAL PEDESTRIAN ACCESS</b>
<b>CHAPTER 8.</b>	<b>PEDESTRIAN CROSSINGS</b>
<b>CHAPTER 9.</b>	<b>BIKEWAY DESIGN</b>
<b>CHAPTER 10.</b>	<b>TRANSIT ACCOMMODATIONS</b>
<b>CHAPTER 11.</b>	<b>TRAFFIC CALMING</b>
<b>CHAPTER 12.</b>	<b>STREETScape ECOSYSTEM</b>
<b>CHAPTER 13.</b>	<b>RE-PLACING STREETS: PUTTING THE PLACE BACK IN STREETS</b>
<b>CHAPTER 14.</b>	<b>DESIGNING LAND USE ALONG COMPLETE STREETS</b>
<b>CHAPTER 15.</b>	<b>RETROFITTING SUBURBIA</b>
<b>APPENDIX A.</b>	<b>BROWARD COMPLETE STREETS COMMUNITY ENGAGEMENT REPORT</b>
<b>APPENDIX B.</b>	<b>BROWARD COMPLETE STREETS POLICY SCAN</b>
<b>APPENDIX C.</b>	<b>MODEL SMART GROWTH ORDINANCE</b>
<b>APPENDIX D.</b>	<b>VISIONS OF TRANSFORMING STREETS</b>
<b>APPENDIX E.</b>	<b>HELPFUL LINKS</b>



## BROWARD ACKNOWLEDGEMENTS

The *Broward Complete Streets Guidelines* document is based on the original work of the *Los Angeles County Model Design Manual for Living Streets*. The *Broward Complete Streets Guidelines* document is funded through a Transforming Our Community’s Health (TOUCH) grant, which is part of the U.S. Department of Health and Human Services’ Community Transformation Grants to support public health efforts to reduce chronic diseases, promote healthier lifestyles, reduce health disparities, and control health care spending.

Local officials in Broward County have modified this manual as appropriate for Broward-specific conditions, laws, regulations, standards, and policies. The Broward Complete Streets Technical Advisory Committee (TAC) was assembled to provide the technical assistance in preparing the document.

A complete list of the Broward Complete Streets Initiative Technical Advisory Committee (TAC) members is listed below:

- Alena Alberani, Sustainable Community Partners
- Scott Brunner, Broward County Traffic Engineering
- Paul Carpenter, City of Coral Springs
- Aylin Costa, Broward County Highway Construction and Engineering
- Andi Crawford, Broward YMCA
- Bill Cross, South Florida Regional Transportation Authority
- Heslop Daley, City of Fort Lauderdale
- Arlene Davis, Port Everglades
- Eric Dumbaugh, Florida Atlantic University
- Ellen Feiler, Broward County Department of Health
- Maribel Feliciano, Broward County Air Quality
- Jerry Ferguson, City of Deerfield Beach
- Pattie Gertenbach, Broward Bicycle/Pedestrian Advisory Committee
- Carolina Gutierrez, University of Miami – Miller School of Medicine
- Lori Hall, City of Miramar
- Ronald Kareiva, FDOT
- Gloria Katz, Smart Growth Partnerships
- Lynn Kunins, Florida Introduces Physical Activity and Nutrition to Youth (FLIPANY)
- Rick Labinsky, Hallandale Beach
- Michael Madfis, Community Involvement Roundtable/Smart Growth Partnership
- Amanda Martinez, City of Deerfield Beach
- John-Mark Palacios, FDOT Office of Modal Development
- Teina Phillips, Broward Regional Health Planning Council
- John Ramos, Broward County Transit
- Joy Riddell, AARP



- Jonathan Roberson, Broward County Transit
- John Rude, Broward Urban River Trails
- Peter Schwarz, Broward County Planning Council
- Richard Tornese, Broward County Highway Construction and Engineering
- Kevin Walford, City of Fort Lauderdale
- Ben Ziskal, City of Margate

Staff:

- Priscila Clawges, Broward MPO
- Anamarie Garces, Urban Health Partnerships
- Patrice Gillespie Smith, Urban Health Partnerships
- Mark Horowitz, Broward MPO
- Stewart Robertson, Kimley-Horn and Associates
- Christopher Ryan, Broward MPO



*Broward Complete Streets TAC Meeting  
(Credit: Kimley-Horn and Associates, Inc.)*



## LOS ANGELES ACKNOWLEDGEMENTS

---

**Suzanne Bogert**, Director of RENEW, Los Angeles County Department of Public Health.

**Ryan Snyder**, President of Ryan Snyder Associates, Federal Highway Administration Pedestrian Safety Design Instructor, Complete Streets Instructor, National Safe Routes to School Instructor. National Sustainable Building Program Instructor. UCLA Urban Planning Instructor. Coordinated street manual project, worked on all chapters, and contributed many of the photos.

**Colleen Callahan**, Deputy Director of the UCLA Luskin Center for Innovation. Managed “Streetscape Ecosystem” chapter.

**Michael Ronkin**, Owner, Designing Streets for People LLC. Complete Streets Instructor, Federal Highway Administration Pedestrian Safety Design Instructor. Provided content editing for entire manual.

---

**Jean Armbruster**, Director of the Policies for Livable, Active Communities and Environments (PLACE) program for the Los Angeles County Department of Public Health. Contributed to “Universal Pedestrian Access” chapter.

**Edward Belden, LEED-AP**. Senior Scientist at the Council for Watershed Health. Contributed to “Streetscape Ecosystem” chapter.

**Pippa Brashear**, Project Manager at Project for Public Spaces. Contributed to “Re-Placing Streets” chapter.

**Madeline Brozen**, Program Director for the UCLA Complete Streets Initiative, UCLA Luskin School of Public Affairs. Contributed to “Vision, Goals, Policies, and Benchmarks” chapter.

**Marty Bruinsma**, Graphic Designer and Artist. Illustrated numerous graphics throughout this manual.

**Dan Burden**, Executive Director of the Walkable and Livable Communities Institute, internationally recognized authority on bicycle and pedestrian facilities and creating livable communities. Contributed to all chapters and contributed many of the pictures.

**Julia Campbell, LEED AP, EIT**. Master of Urban and Regional Planning student at the UCLA Luskin School of Public Affairs; graduate student researcher for the UCLA Luskin Center for Innovation and formerly a hydraulic engineer focusing on stormwater management. Contributed to and edited “Streetscape Ecosystem” chapter.



**Lisa Cirill, M.S., P.A.P.H.S.** Chief of California Active Communities, a joint unit of the California Department of Health and the University of California, San Francisco. Contributed to “Vision, Goals, Policies, and Benchmarks” chapter.

**Art Cueto**, Planning Manager at Transtech. Contributed to “Transit Accommodations” chapter.

**J.R. DeShazo**, Director of the UCLA Luskin Center for Innovation. Contributed to “Streetscape Ecosystem” chapter.

**Peter Eun**, Member, Federal Highway Administration Resource Center Safety and Design Team. Federal Highway Administration Pedestrian Safety Design Instructor. Contributed to “Pedestrian Crossings” chapter.

**Charlie Gandy**, Mobility Coordinator for the City of Long Beach, California. Contributed to “Vision, Goals, Policies, and Benchmarks” chapter.

**Norman Garrick, Ph.D.** Associate Professor at the University of Connecticut in the Department of Civil and Environmental Engineering. Board member of the Congress for New Urbanism. Contributed to “Street Networks and Classifications” chapter.

**Said Gharbieh, BSc, MSc, FCIHT, FCIT, MBIM.** Principal at Arup. Leads Arup’s transportation planning business in Southern California. Contributed to “Street Networks and Classifications” chapter.

**Ellen Greenberg, PE.** Associate Principal at Arup; heads the Integrated Planning department. A lead author of *Context Sensitive Design Solutions for Major Urban Thoroughfares for Walkable Communities*. Contributed to “Street Networks and Classifications” chapter.

**Gayle Haberman**, Policy Analyst of the Policies for Livable, Active Communities and Environments (PLACE) program for the Los Angeles County Department of Public Health. Contributed to “Vision, Goals, Policies, and Benchmarks” chapter.

**Andre Haghverdian, PE.** President of Pivot Group, Inc., a civil engineering and construction firm. Contributed to “Streetscape Ecosystem” chapter.

**Holly Harper**, Architect and Initiative Coordinator for Calles Para la Gente Boyle Heights. Contributed to “Streetscape Ecosystem” chapter.

**Billy Hattaway**, Managing Director of Transportation, Florida, with VHB Miller Sellen. Author of the new “Traditional Neighborhood Development” chapter of the Florida GreenBook. Contributed to “Traveled Way Design” chapter and “Intersection Design” chapter.

**Brett Hondorp, AICP.** Vice President, Association of Pedestrian and Bicycle Professionals. Principal with Alta Planning + Design. Contributed to “Bikeway Design” chapter.



**Julia Lave Johnston**, Director of the Land Use and Natural Resources Program at the University of California, Davis, Extension. Formerly Deputy Director for Planning Policy in the California Governor's Office of Planning and Research. Contributed to "Vision, Goals, Policies, and Benchmarks" chapter.

**Peter Lagerwey**, Senior Planner and Regional Office Director for Toole Design Group in Seattle, Washington. Federal Highway Administration Pedestrian Safety Design Instructor, Complete Streets Instructor, National Safe Routes to School Instructor. Contributed to "Pedestrian Crossings" chapter.

**Brad Lancaster**, Author of *Rainwater Harvesting for Drylands and Beyond*. Conducts permaculture consulting, design, and education. Contributed to "Streetscape Ecosystem" chapter.

**Stephanie Landregan, FASLA, LEED-AP**. Director for the Landscape Architecture Program at UCLA Extension. City of Glendale Planning Commissioner. Contributed to "Streetscape Ecosystem" chapter.

**Ian Lockwood, PE, Loeb Fellow**. Principal at AECOM. Widely recognized as one of the leading traffic engineers in North America. Contributed to "Street Networks and Classifications" chapter, "Traffic Calming" chapter, and "Community Engagement" chapter.

**Jana Lynott, AICP**. Senior Strategic Policy Advisor for Transportation and Livable Communities at the Public Policy Institute of AARP. Author of *Planning Complete Streets for an Aging America*. Contributed to "Universal Pedestrian Access" chapter and "Designing Land Use" chapter.

**Mukul Malhotra**, Principal at MIG, Inc. Coordinator of 2011 Streets Project Conference in Berkeley, California. Contributed to "Traveled Way Design" chapter and "Intersection Design" chapter.

**Tim Mann, RLA**. Principal at Lynn Capouya, Inc. Landscape Architects. Contributed to "Streetscape Ecosystem" chapter.

**Barbara McCann**, Executive Director of the National Complete Streets Coalition. Contributed to "Vision, Goals, Policies, and Benchmarks" chapter.

**Cullen McCormick**, UCLA Urban Planning Masters Student. Contributed to manual design.

**Jessica Meaney**, California Policy Manager for the Safe Routes to School National Partnership. National Safe Routes to School Instructor. Contributed to "Vision, Goals, Policies, and Benchmarks" chapter.



**Lys Mendez**, master's student of urban planning at UCLA. Contributed preliminary editing.

**Rock Miller, PE**. President-elect of the Institute of Transportation Engineers. Principal at Stantec. Contributed to Chapters 1, 5, 6, and 9.

**Kelly Morphy**, Director of Outreach and Communications, Walkable and Livable Communities Institute. Contributed to "Community Engagement" chapter.

**Michael Moule, PE, TE, PTOE**. Principal at Nelson\Nygaard Consulting Associates. Past president of the Association of Pedestrian and Bicycle Professionals. Co-author of the 2011 AASHTO Bike Guide, co-author of *Roundabouts: An Informational Guide*, 2010. Federal Highway Administration Pedestrian Safety Design Instructor, Complete Streets Instructor, Contributed to "Traveled Way Design" chapter, "Intersection Design" chapter, and "Bikeway Design" chapter.

**Deborah Murphy, Associate AIA**. Principal of Deborah Murphy Urban Design + Planning and Founder of Los Angeles Walks. Contributed to "Streetscape Ecosystem" chapter.

**Narasimha Murthy, Ph.D., TE**. President of Murthy Transportation Consultants. Contributed to "Traveled Way Design" chapter and "Intersection Design" chapter.

**Margot Ocañas**, Policy Analyst with the Renewing Environments for Nutrition, Exercise, and Wellness (RENEW) program for the Los Angeles County Department of Public Health. Assisted on several chapters.

**Lisa Padilla, AIA, LEED-AP**. Architect and Urban Designer. Principal of Cityworks Design. Contributed to "Designing Land Use" chapter.

**Simon Pastucha**, Chief Urban Designer for the City of Los Angeles. Contributed to "Designing Land Use" chapter and "Community Engagement" chapter.

**Jen Petersen, Ph.D.** Urban sociologist. Chief Officer of Ideas and Operations at Creative Commercial Real Estate in New York City. Contributed to "Re-Placing Streets" chapter.

**Grace Phillips**, Principal of Gracescapes. Sustainable landscape professional. Master's of Urban Planning student. Contributed to "Streetscape Ecosystem" chapter.

**Francis Reilly**, Urban Planner. Prepared the InDesign layout for the manual.

**James Rojas**, Urban Planner. Founder of the Latino Urban Forum. Contributed to "Transit Accommodations" chapter.

**David Sargent**, Principal at Sargent Town Planning. Contributed to "Designing Land Use" chapter.



**Will Schroeer**, Director of Policy and Research for Smart Growth America. Wrote “Retrofitting Suburbia” chapter.

**Jessica Scully**, Writer and Editor. Former technical communication instructor at the University of California, Irvine. Edited the entire manual.

**Chanda Singh**, Transportation Planner with Ryan Snyder Associates. Contributed to “Street Networks and Classifications” chapter and “Universal Pedestrian Access” chapter.

**Heather Smith**, Planning Director of the Congress for New Urbanism. Played a significant role in producing the *Context Sensitive Design Solutions for Major Urban Thoroughfares for Walkable Communities*. Contributed to “Street Networks and Classifications” chapter.

**Pat Smith, ASLA, AICP, Certified Arborist**. Principal of Patricia Smith Landscape Architecture. Contributed to “Streetscape Ecosystem” chapter.

**Gary Toth**, Senior Director, Transportation Initiatives for the Project for Public Spaces. Primary author of the Pennsylvania and New Jersey State Departments of Transportation *Smart Transportation Guide*. Contributed to “Transit Accommodations” chapter.

**Michael Wallwork, PE**. President of Alternate Street Design. Traffic engineer and nationally renowned roundabout and traffic calming designer. Contributed to “Traveled Way Design” chapter, “Intersection Design” chapter, and “Traffic Calming” chapter.

**Michele Weisbart**, Graphic and Web Designer. Created most of the graphics in the manual as well as the layout.

**Scott Windley**, Accessibility Specialist, U.S. Access Board. Contributed to “Universal Pedestrian Access” chapter.

**Will Wright**, Director of Government and Public Affairs for the American Institute of Architects in Los Angeles. Contributed to “Vision, Goals, Policies, and Benchmarks” chapter.

**Sky Yim**, Sky Yim Photography. Contributed many of the photos.

**Paul Zykofsky, AICP, Associate AIA**. Associate Director, Local Government Commission. Federal Highway Administration Pedestrian Safety Design Instructor, Complete Streets Instructor, National Safe Routes to School Instructor. Contributed content editing.



## RIGHT TO USE THIS MANUAL

The *Los Angeles County Model Design Manual for Living Streets* is available for any jurisdiction to use. Jurisdictions may adopt, customize, or modify the manual to meet their needs. The manual's sponsors ask only two things:

1. That jurisdictions maintain the acknowledgements to credit the individuals who worked so hard to produce the manual.
2. That jurisdictions notify the manual's website ([www.modelstreetdesignmanual.com](http://www.modelstreetdesignmanual.com)) to allow the sponsors to track which communities have adopted the manual at least in substantial part.

Thank you.



# INDEX TABLE

COMPLETE STREET CONCEPT	CHAPTER														
	1. Introduction	2. Vision	3. Public Engagement	4. Street Networks	5. Traveled Way	6. Intersections	7. Pedestrian Access	8. Pedestrian Crossings	9. Bikeway Design	10. Transit Accommodations	11. Traffic Calming	12. Streetscape Ecosystem	13. Re-Placing Streets	14. Designing Land Use	15. Retrofitting Suburbia
AASHTO	0				0	0	0	0	0						
Active Transportation	0		0	0									0		0
ADA Access	0						0			0		0			
Bicycle Boulevards				0					0		0				
Bicycle Detector									0						
Bicycle Parking								0	0	0					
Bus Stops					0		0			0			0		0
Capacity	0			0	0	0					0			0	0
Clear Zone					0										
Context Sensitive Design	0	0		0	0						0				
Cross Sections					0		0								
Crosswalks						0	0	0			0	0			0
Curb Extensions					0	0	0	0		0	0	0	0		0
Curb Ramps						0	0	0				0			
Curb Zone							0								
Detectable Warning Surface							0								
Design Speed					0										
Economic Activity	0		0	0								0	0		0
Emergency Response			0	0	0						0				



COMPLETE STREET CONCEPT	CHAPTER														
	1. Introduction	2. Vision	3. Public Engagement	4. Street Networks	5. Traveled Way	6. Intersections	7. Pedestrian Access	8. Pedestrian Crossings	9. Bikeway Design	10. Transit Accommodations	11. Traffic Calming	12. Streetscape Ecosystem	13. Re-Placing Streets	14. Designing Land Use	15. Retrofitting Suburbia
Equity	o	o	o	o									o		
Festival Streets	o			o									o		
Florida Greenbook	o								o						
Frontage Zone							o			o					
Furniture Zone (Amenity Zone)							o			o					
Grid Street Networks				o											o
Health	o	o	o	o			o		o				o	o	o
Healthy Communities	o	o		o										o	
Intersections				o	o	o	o	o	o		o				
Land Use	o	o		o			o							o	o
Landscaping	o	o			o	o	o		o		o	o		o	o
Lane Widths	o				o				o						o
Leading Pedestrian Interval						o									
Lighting					o			o	o	o	o	o		o	
Livability	o													o	o
Medians					o	o		o	o	o	o	o			
Median Islands					o	o		o			o	o			o
Mode Choice				o						o					
MUTCD	o					o	o	o	o						
On-Street Parking		o		o	o	o	o	o	o	o	o	o		o	o



COMPLETE STREET CONCEPT	CHAPTER														
	1. Introduction	2. Vision	3. Public Engagement	4. Street Networks	5. Traveled Way	6. Intersections	7. Pedestrian Access	8. Pedestrian Crossings	9. Bikeway Design	10. Transit Accommodations	11. Traffic Calming	12. Streetscape Ecosystem	13. Re-Placing Streets	14. Designing Land Use	15. Retrofitting Suburbia
Pedestrian Refuge					o	o		o			o				o
Pedestrian Zone							o								
Public Art												o	o		
Public Engagement			o												
Road Diets			o		o			o	o		o				o
Roundabouts			o			o					o	o			
Safety	o	o	o	o	o	o	o	o	o	o	o	o	o	o	o
Shading / Trees		o	o		o		o			o	o	o	o	o	
Shared Space Streets				o	o						o		o		
Smart Growth	o	o	o								o			o	o
Street Furniture					o	o	o					o			
Street Types				o						o					
Sustainability	o		o	o								o	o	o	
Sustainable Street Network				o											
Technical Advisory Committee	o	o													
Transect				o	o			o							
Transit Signal Priority										o					
Travel Lanes					o										
Turn Lanes					o	o			o		o				o



## 1. INTRODUCTION

CONTEXT .....	1
WHAT ARE COMPLETE STREETS? .....	2
Why Complete Streets? .....	2
PURPOSE OF THE COMPLETE STREETS GUIDELINES .....	6
LEGAL STANDING OF STREET MANUALS .....	7
American Association of State Highway Transportation Officials (AASHTO) Green Book .....	7
Florida Greenbook .....	8
Broward County Public Works Guidelines .....	8
Florida Department of Transportation (FDOT) Plans Preparation Manual (PPM) .....	8
Manual on Uniform Traffic Control Devices (MUTCD) .....	9
Americans with Disabilities Act (ADA) Regulations And Standards .....	11
Local Street Manuals .....	12
HOW TO USE THE COMPLETE STREETS GUIDELINES MANUAL .....	14
ADOPTION AND IMPLEMENTATION .....	15
HOW THE BROWARD COMPLETE STREETS GUIDELINES DOCUMENT WAS CREATED .....	16
Broward Complete Streets Technical Advisory Committee .....	16
HOW THE ORIGINAL L.A. LIVING STREETS MODEL MANUAL WAS CREATED .....	20



*(Credit: Kimley-Horn and Associates, Inc.)*



## CONTEXT

A growing number of communities are discovering the value of their streets as important public spaces for many aspects of daily life. People want streets that accommodate all modes of transportation, are safe to cross or walk along, link healthy neighborhoods, offer places to meet people, connect us to daily needs, and have a vibrant mix of land uses. More people are enjoying the value of farmers' markets, street festivals, and gathering places, and are expressing the desire to walk and ride bicycles throughout their neighborhoods.



*Complete Streets accommodate all users  
 (Credit: City of Portsmouth, VA, and Urban Advantage)*

People from a wide variety of backgrounds are forming partnerships with schools, parks, health agencies, neighborhood associations, environmental organizations, and other groups in asking their local governments to create streets and neighborhoods that fit this vision. In Broward County, municipalities are pursuing Smart Growth policies, which encompass Complete Streets. In fact, the Smart Growth America organization recently incorporated Complete Streets into its mission. Complete Streets are an essential ingredient in creating livable, walkable neighborhoods.

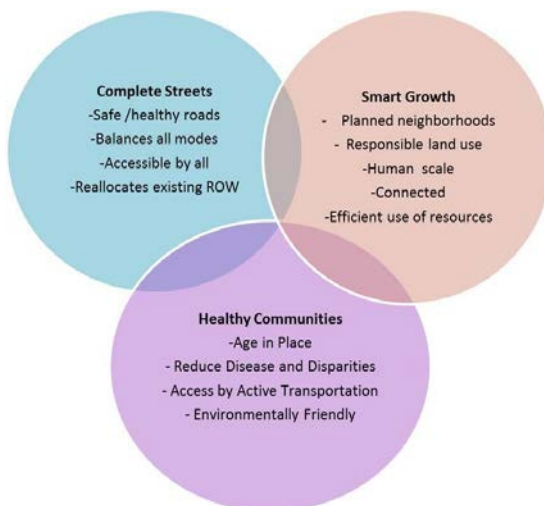

*The Complete Streets, Smart Growth, and  
 Healthy Communities partnership  
 (Credit: Urban Health Partnerships, Inc.)*

As a result, an increasing number of local governments are looking to modify the way they design their streets. They are often stifled by standards and guidelines that prevent them from making the changes they seek. Some want to modify their standards and manuals, but don't know how, or don't have the resources. The *Broward Complete Streets Guidelines* manual presents an opportunity for communities to design their streets for smart growth, health, safety, livability, sustainability, and more. It also provides a template that can be adopted to replace existing local manuals. The sponsors of this manual make it freely available to any community that wants to use



all or any part of it. This manual may be modified, customized, or expanded upon at the pleasure of the end user. The manual will be made widely available in hopes that many more communities will fulfill their objectives in making and remaking their streets as valuable public space that serves many needs.

## WHAT ARE COMPLETE STREETS?

**A Complete Street, as defined by the National Complete Streets Coalition (NCSC), is a street where the entire right-of-way is planned, designed, and operated for all modes of transportation and all users regardless of age or ability. Pedestrians, bicyclists, transit riders, and motorists of all ages and abilities must be able to safely move along and across a Complete Street. Complete Streets make it easy to cross the street, walk to shops, catch the bus, bike to work, and enjoy many other healthy activities.**

As described by the NCSC, there is no singular design prescription for complete streets – each one is unique and responds to its community context (*Complete Streets FAQ*, National Complete Streets Coalition, [www.completestreets.org](http://www.completestreets.org)). Some features that a complete street may include are sidewalks, bike lanes (or other innovative bicycle facilities), special bus lanes, comfortable and accessible public transportation stops, frequent and safe crossing opportunities, median refuges, accessible pedestrian signals, landscaped curb extensions, bioswales, roundabouts, on-street parking, and secure bicycle parking, among others. A complete street in a suburban area may look different than a complete street in the urban core, but both are designed with the same principles in mind to balance safety and convenience for everyone using the road.



*Comfortable public transportation stop  
(Credit: Human Transit)*

## WHY COMPLETE STREETS?

Incomplete streets – those designed with only cars in mind – limit transportation choices by making walking, bicycling, and taking public transportation inconvenient and unattractive.

Conventional street design solely to move motor vehicle traffic must be modified to conform to the complete streets goal. Incomplete streets either directly or indirectly cause a number of problems for communities, including the following:

***“Currently, everyone drives. I’ll end up moving to a city with higher walkability if we can’t change this.”***

- (24-year old North Lauderdale Broward Complete Streets Public Workshop participant)



- Lack of opportunity to be active as part of daily life; therefore increasing probability of chronic diseases and other negative health outcomes attributed to sedentary lifestyles.
- Lack of viable transportation choices.
- Senior citizens being geographically limited because they cannot cross streets.
- Children becoming overweight, unnecessary neighborhood congestion, and air pollution around schools, all due to children being driven to school rather than walking.
- Unnecessary driving for short trips.
- Overconsumption of energy.
- Unnecessary emission of greenhouse gases.
- Economic hardship and recession when energy prices rise.
- Streets that do not support neighborhood retail.
- Neighborhoods that lack livability.
- Polluted waterways.
- Underground water aquifers drying up.
- Dehydrated streetscapes causing unnecessary importation of water for landscaping.
- Uplifted sidewalks.

However, complete streets reverse this outcome by providing the following benefits among others.

**Capacity.** Complete streets can improve the efficiency and capacity of existing roads by moving more people in the same amount of space. Complete streets can maintain volume, reduce speeds, and conveniently accommodate bicyclists and pedestrians. Increasing productivity out of the existing road and public transportation system is vital to reducing congestion.

**Equity.** Complete streets are for everyone. People of all ages, abilities, and income will have more options when making essential trips such as to work, school, the grocery store, or for healthy recreation. Walking, bicycling, and taking public transportation are less expensive forms of personal transportation than relying on automobiles.

**Public Health.** Complete streets promote active transportation, which is human-powered transport (walking, bicycling, accessing public transit). Currently, one-third of our nation's children are overweight or obese according to the Centers for Disease Control and Prevention (CDC). The CDC identified a strong correlation between planning and investments in infrastructure and some of the most serious health concerns facing the United States, including heart disease, obesity, and diabetes.

**Safety.** Making these travel choices more convenient and attractive means making them safer. Half of Haddon's ten strategies for road traffic injury prevention mirror Complete Streets principles (*Road Traffic Injury Prevention Training Manual, TRIPP, 2006*). Roadway improvements that have been recommended to reduce the annual toll of injuries and fatalities to pedestrians and bicyclists are well documented (Zegeer, C., et al, "*Analysis of Elderly Pedestrian Accidents and Recommended Countermeasures*", 1993). Adding complete streets



*Image of a complete street within a main street corridor context  
(Credit: AARP)*

elements to existing roadways improves safety for all users (Hallett, I., et al, “*Evaluation of On-Street Bicycle Facilities Added to Existing Roadways*”, 2006).

**Sustainability.** The Broward Metropolitan Planning Organization (MPO) 2035 *Long Range Transportation Plan* (LRTP) calls for a shift from investment in automobile-centric projects to transit and other modes that support transit. Complete streets support this sustainable transportation vision established by the MPO and its constituencies.

**The Time is Right.** Many interests are aligning for safer, healthier streets. AARP, American Public Health Association (APHA), Safe Routes to School National Partnership, Smart Growth America, Institute of Transportation Engineers (ITE), American Planning Association (APA), American Society of Civil Engineers (ASCE), and many other national organizations have demonstrated being a strong supporter of complete streets. Locally, more than 1,800 Broward residents across many walks of life and employees from diverse professions participated in Complete Streets Phase 1 Public Involvement. Survey results from the Phase 1 Public Involvement indicate that two-thirds of residents who stated they would never travel without a car in current conditions, would consider walking and biking to nearby destinations if one or more Complete Streets elements were incorporated in the right-of-way. After an information session, 98 percent of the participants stated they wanted to see Complete Streets in their local communities.

More than 100 cities across the United States and at least three MPOs have adopted complete streets policies. Many local governments right here in Broward County are already beginning to redesign their streets to conveniently accommodate more modes of transportation. Furthermore, through the Centers for Disease Control and Prevention (CDC) Communities Transformation Grant, locally known as the Transforming Our Community’s Health (TOUCH) initiative, Broward County municipalities have the opportunity to receive technical assistance to pursue Smart Growth policies by encouraging supportive land use decisions. These policies will provide a strong framework for the implementation of complete streets based on the Smart Growth principles listed below.



- Provide a range of housing opportunities and choices.
- Aim to increase efficiency of utilizing water and energy resources.
- Preserve and create open space.
- Create distinctive buildings and neighborhoods with a strong sense of place.
- Promote mixed land uses serviced by a variety of transportation modes.
- Make development decisions more predictable, quicker and cost effective.
- Create walkable sites, neighborhoods and community designs.
- Encourage community and stakeholder collaboration.
- Promote regional collaboration.
- Strengthen and direct development towards existing communities.
- Take advantage of compact building design.



*The Promenade at Coconut Creek, which is the first project of Coconut Creek's Main Street Area vision for a sustainable, mixed-use downtown district that incorporates Smart Growth principles through adopted design standards.*

*(Credit: Kimley-Horn and Associates, Inc.)*



*Hillsboro Boulevard bike lane and streetscaping  
(Credit: City of Deerfield Beach)*

## PURPOSE OF THE COMPLETE STREETS GUIDELINES

Local governments depend on manuals for design guidance on new streets, as well as for retrofitting and modifying existing streets with new development, and when new subdivisions are being built. Along with land use planning, street manuals play a large role in determining urban form. Street manuals, in effect, serve as the “DNA” of streets. As such, they help to determine how walkable and bicycle-friendly neighborhoods and communities are, how conducive cities are to transit use, and how livable communities become.

The *Broward Complete Streets Guidelines* manual is based on complete streets principles that aim to design streets for people of all ages and physical abilities and accommodate all travel modes. The *Broward Complete Streets Guidelines* manual offers another way to design streets and provides guidance for those municipalities that decide to adopt these principles. The result will be more livable neighborhoods with healthier residents due to opportunities for increasing social capital (by interacting more regularly with neighbors) and for active transportation (walking, bicycling, and accessing public transportation).



*Roundabouts are a complete street strategy  
(Credit: Alena Alberani)*



## LEGAL STANDING OF STREET MANUALS

Local jurisdictions generally follow some established standards for designing streets. Much confusion exists as to what they must follow, what is merely guidance, when they can adopt their own standards, and when they can use designs that differ from existing standards. This section untangles the myriad of accepted design documents. It is critical for local jurisdictions to understand how adopting the *Broward Complete Streets Guidelines* meshes with other standards and guides. The most important of those standards and guides are the following.

- The American Association of State Highway and Transportation Officials’ (AASHTO) *A Policy on Geometric Design of Highways and Streets* (the “Green Book”)
- The *Manual of Uniform Minimum Standards for Design, Construction, and Maintenance for Streets and Highways* (the “Florida Greenbook”)
- Broward County Public Works Guidelines
- The Florida Department of Transportation’s (FDOT) *Plans Preparation Manual* (PPM)
- The Federal Highway Administration’s (FHWA) *Manual on Uniform Traffic Control Devices for Streets and Highways* (MUTCD)
- Americans with Disabilities Act (ADA) regulations and standards
- Local manuals or street design standards

A description of the federal-aid roadway classification system helps to frame the requirements of each of these documents. For the purposes of understanding design standards and guides, the federal roadway classification system is the existing system of street classification for federal funding. Local governments that wish to use certain federal funds allocated by the federal-aid system are required to use a streets classification system based on arterials, collectors, and local streets. The federal-aid system encourages cities to designate more of these larger streets and concentrate modifications along the larger streets. In Chapter 4, “Street Networks and Classifications,” an alternative system that is based on context is recommended. In order to maintain eligibility to access these funds, local jurisdictions can use both systems, for example, arterials/collectors and urban boulevards/avenues.

### AASHTO GREEN BOOK

*A Policy on the Geometric Design of Highways and Streets* (the AASHTO Green Book, 6<sup>th</sup> Edition, 2011) provides guidance for designing geometric alignment, street width, lane width, shoulder width, medians, and other street features. Design guidelines are given for intersections, freeways, arterials, collectors, and local roads. The intent of the Green Book is to provide guidance to designers by referencing a recommended range of values for dimensions; it is not intended to be a detailed design manual that could supersede the need for the application of sound engineering principles by the designer. Although the Green Book’s guidelines are generally organized by functional classification, some local

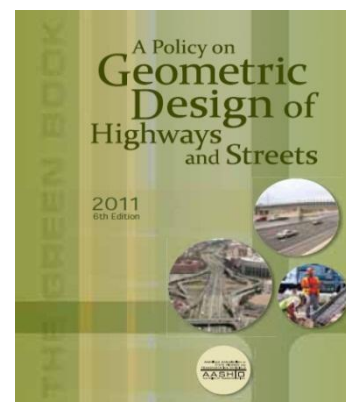



jurisdictions apply its guidelines uniformly to all streets.

Furthermore, the Green Book provides guidance that local jurisdictions often unnecessarily treat as standards. The Green Book encourages flexibility in design within certain parameters to permit independent designs tailored to particular situations. In addition, AASHTO published *A Guide for Achieving Flexibility in Highway Design* to further this context-sensitive approach. For example, 10-foot lanes, which local jurisdictions often avoid out of concerns of deviating from standards, are well within AASHTO guidelines.

#### FLORIDA GREENBOOK

The *Manual of Uniform Minimum Standards for Design, Construction, and Maintenance for Streets and Highways* (the Florida Greenbook) is intended to provide minimum standards for use on all public streets that are not part of the State Highway System. Florida Administrative Code Rule 14-15.002, which adopted the May 2011 Florida Greenbook, became effective June 4, 2012. Significant modifications are included in the May 2011 Florida Greenbook that expand Chapter 8 (Pedestrian Facilities) and Chapter 9 (Bicycle Facilities) to provide improved guidance. In addition, a new chapter on Traditional Neighborhood Development (TND) was added to the Florida Greenbook since the previous 2007 version. The Florida Greenbook is available on the FDOT website (<http://www.dot.state.fl.us/rddesign/FloridaGreenbook/FGB.shtm>).

#### BROWARD COUNTY PUBLIC WORKS GUIDELINES

The *Final Report on Alternative Roadway Design Guidelines for Broward County* (May 2008) outlines roadway design guidelines consistent with one of the County's priority goals of establishment of a "sense of place". The guidelines are consistent with the county-wide *Community Design Guidebook* (CDG), prepared by the local architecture firm Anthony Abbate Architect, P.A., which develops, promotes, and sets forth the basis for implementing urban design guidelines and principles for use within Broward County that are sensitive to emphasizing and reinforcing the distinctive character of the County and the unique charm of its various cities and places. As an example, the CDG's "Urban Main Street" illustrative street sections, developed with county engineering, transit, and transportation agencies, typically include 11-foot wide travel lanes, on-street parking, bicycle lanes, wide sidewalks, and small turning radii at street intersections.

#### FDOT PLANS PREPARATION MANUAL

The FDOT *Plans Preparation Manual* (PPM) Volume I outlines the design criteria and procedures for use on the State Highway System (SHS) and on FDOT projects. The criteria in the PPM represent requirements for the State Highway System, which must be met for the design of FDOT projects unless approved

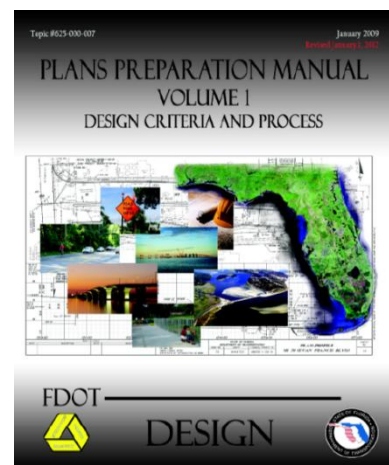



exceptions or variations are obtained in accordance with procedures outlined in the PPM. The PPM Volume I contains several chapters of interest to implementing complete streets on the SHS including Chapter 2 (Design Geometrics and Criteria), Chapter 8 (Pedestrian, Bicycle, and Public Transit Facilities), Chapter 21 (Transportation Design for Livable Communities), and Chapter 25 (Design Criteria for Resurfacing, Restoration, and Rehabilitation [RRR] projects).

The PPM Volume II sets forth requirements for the preparation and assembly of contract plans for FDOT projects. Of note is PPM Volume II Chapter 6, which includes typical cross sections.

## MUTCD

The Federal Highway Administration's (FHWA) *Manual on Uniform Traffic Control Devices for Streets and Highways* (MUTCD) provides standards and guidance for the application of all allowed traffic control devices including roadway markings, traffic signs, and signals. FHWA oversees application of the MUTCD. The State of Florida chooses to adopt the Federal MUTCD as its manual for signs, pavement markings, and traffic control devices.

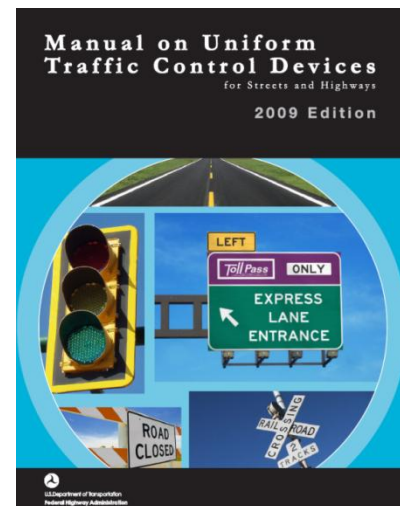

The rules and requirements for the use of traffic control devices are different than for street design criteria. Local agencies have limited flexibility to deviate from the provisions of the MUTCD in the use of traffic control devices due to the relationship between the MUTCD, the Code of Federal Regulations (CFR), and state law. The MUTCD does provide flexibility and options within its general provisions for items such as application of standard traffic control devices, use of custom signs for unique situations, traffic sign sizes, and sign placement specifics. However, agencies do not generally have the flexibility to develop signs that are similar in purpose to signs within the MUTCD while using different colors, shapes, or legends. Agencies also are not authorized to establish traffic regulations that are not specifically allowed or are in conflict with state law. The provisions of the MUTCD and related state laws thus make it cumbersome to deploy new traffic control devices. This can result in complications, especially in the areas of speed management, pedestrian crossings, and bikeway treatments.

### Request for Experimentation

The State of Florida and the Federal Highway Administration have procedures called "Request for Experimentation" (RFE) that allow local agencies to experiment with traffic control devices that are not included in the current MUTCD. Such demonstrations are not difficult to obtain from FHWA for testing of new devices, especially as they relate to pedestrian and bicycle facilities, but the requesting agency must agree to conduct adequate before-and-after studies, submit reports on the performance of the experimental device, and remove the device if early results are not promising (see FHWA flow chart on the following page). Once federal approval



is granted for the experiment, the local jurisdiction has been given some legal protection from liability suits.

The MUTCD is amended through experimentation. After one or more experiments have shown benefit, the new devices are sometimes adopted into the manual. A recent example of a successful amendment to the MUTCD is the shared lane bicycle marking (sharrow). More information on sharrows can be found in Chapter 9, "Bikeway Design."



*Sharrow pavement marking  
(Credit: Kimley-Horn and Associates, Inc.)*

**OBTAINING EXPERIMENTATION APPROVAL  
FOR NEW  
TRAFFIC CONTROL DEVICES**

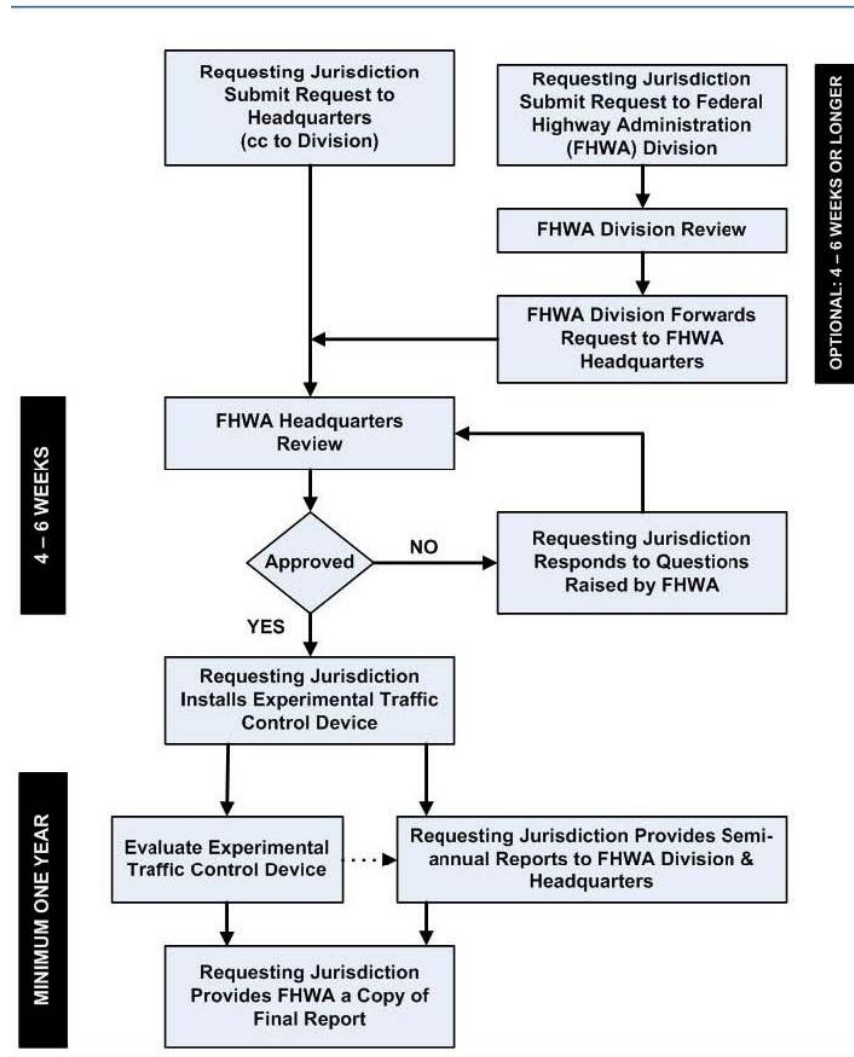

*MUTCD experimentation process  
(Source: Federal Highway Administration)*



## Warrants

The MUTCD establishes warrants for the use of some traffic control devices. For example, stop signs and traffic signals are expected to meet minimum thresholds before application. These thresholds include such criteria as number of vehicles, number of pedestrians or other users, distance to other devices, crash history, and more. These warrants are often viewed as preventing local engineers from applying devices that, in their opinion, may improve safety. For example, trail and/or pedestrian crossings of busy, high-speed, wide arterial streets may need signals for user safety, but signals may not meet the MUTCD warrants.

However, the MUTCD suggests that strict adherence to the warrants is not the only factor to evaluate when considering whether a traffic control device is justified. The warrants are a component of a broader engineering investigation, and are not a substitute for engineering judgment. The MUTCD lists the satisfying of a warrant as “guidance” for implementing an approved traffic control device. Guidance is defined in Section 1A.13 of the 2009 MUTCD as “a statement of recommended, but not mandatory, practice in typical situations, with deviations allowed if engineering judgment or engineering study indicates the deviation to be appropriate.” The MUTCD typically uses the verb “should” for guidance conditions, as differentiated from the verb “shall” for standards.

As with street design guidelines, local jurisdictions may establish their own warrants or modify those provided in the MUTCD to suit their context in order to use some traffic control devices. In special circumstances that deviate from the warrants, local jurisdictions need to document their reasons for the variation. For example, local jurisdictions may establish that trail crossings or school crossings qualify for certain traffic control devices.

## ADA REGULATIONS AND STANDARDS

Public rights-of-way and facilities are required by law to be accessible to persons with disabilities through Title II of the Americans with Disabilities Act of 1990 (ADA) (42 U.S.C. 12131-12164) and Section 504 of the Rehabilitation Act of 1973 (Section 504) (29 U.S.C. 794). Agencies must provide ADA accessibility wherever a pedestrian facility exists.

Regulations implement this requirement by imposing standards for accessible features such as curb cuts, ramps, continuous sidewalks, and detectable warnings. The Department of Justice (DOJ) ADA regulation is 28 C.F.R. Part 35. The DOT Section 504 regulation in 49 C.F.R. Part 27 governs public agencies, with the ADA incorporated in 49 C.F.R. 27.19. Any project for construction or alteration of a facility that provides access to pedestrians must be made accessible to persons with disabilities.

The U.S. Access Board is the federal agency responsible for developing ADA design standards. The Access Board’s ADA Accessibility Guidelines serve as the minimum baseline for the standards. The following publications on accessible pedestrian design are available on the Board’s website ([www.access-board.gov](http://www.access-board.gov)).



- ADA Standards for Transportation Facilities
- Accessibility Guidelines (ADAAG)
- Proposed Public Rights-of-Way Accessibility Guidelines (PROWAG)
- Pedestrian Access to Modern Roundabouts
- Detectable Warnings: Synthesis of U.S. and International Practice
- Accessible Pedestrian Signals

The *Broward Complete Streets Guidelines* manual includes design information regarding ADA accessibility in Chapter 7, “Universal Pedestrian Access.”

## LOCAL STREET MANUALS

Local jurisdictions follow the AASHTO Green Book, the Florida Greenbook, or design guidance from organizations such as the Institute of Transportation Engineers (ITE) out of the general need for a comprehensive set of street design guidelines and out of liability concerns. Neither federal nor state law mandates adoption or adherence to these guides. However, local jurisdictions often adopt them to protect themselves from lawsuits. Furthermore, many don’t have the resources to develop their own standards and practices, so they adopt those in the AASHTO Green Book or the Florida Greenbook, or another previously adopted manual, or those of other jurisdictions.

The manuals that many jurisdictions use today embody principles based on moving motor vehicle traffic at the highest speed efficiently practical as the primary role of streets. The result is many wide, high-speed streets that are designed to move cars but compromise other important community goals and may work against present day community needs. Common direct outcomes of existing manuals within urbanized areas can include the following:

- Streets that are nerve-racking and uncomfortable for pedestrians to cross
- Streets that are not safe for bicyclists
- Streets that encourage motor vehicle high speeds
- Streets that are not safe for the motorists they are designed to serve
- Narrow sidewalks with little or no buffer that are not comfortable to walk along
- Inconvenient street crossings for people in wheelchairs
- Unsightly and uninviting streets
- Auto-oriented land uses that are uninviting and intimidating to people walking, biking, and using transit
- Street water runoff systems that funnel rainwater to the storm drains and directly to waterways
- Poor selection of street trees, if any
- Excessive exposed hardscape leading to a rise in temperatures – the heat-island effect

A question often posed by plaintiffs’ attorneys in traffic-related crashes is, “Did the jurisdiction follow established or prevailing designs, standards, and guidance?” If the attorneys can prove



that the local jurisdiction deviated from these, they enhance their chances of winning a judgment against the jurisdiction. Therefore, protection from liability is paramount.

Local governments are authorized to adopt or modify their own practices, standards, and guidelines that may reflect differences from the AASHTO Green Book or the Florida Greenbook. If these changes generally fall within the range of acceptable practice allowed by nationally recognized design standards, the adopting agencies are protected from liability to the same extent they would be if they applied the AASHTO Green Book or the Florida Greenbook. Most changes to streets discussed in the *Broward Complete Streets Guidelines* fall within the range of the guidelines or recommended practices of nationally recognized organizations such as AASHTO, ITE, Urban Land Institute (ULI), and Congress for the New Urbanism (CNU).

Working within previously established urban guidelines generally should result in a design that is protected from liability. The AASHTO Green Book or the Florida Greenbook are silent on many design features, and do not always consider the needs within unique contexts. In these cases, local jurisdictions can develop their own guidelines and standards and incorporate international equivalents or practices from other jurisdictions. Local governments may adopt the guidance in these Guidelines, which compiles best practices in creating complete streets.



*Pedestrians enjoying a wide sidewalk with landscaping  
(Credit: Kimley-Horn and Associates, Inc.)*

Local jurisdictions can also utilize designs that fall outside the ranges specified by nationally accepted guidelines and standards, but these practices can potentially increase liability unless done with great care. When agencies elect to utilize designs that fall outside the guidelines of nationally recognized documents, they need to use additional care to ensure they do not expose themselves to liability.

To minimize liability, local jurisdictions either need to adopt their own standards (which should be based on rationale or evidence of reasonableness), or they can conduct an experimental project (Request for Experimentation) as discussed earlier in the MUTCD sub-section. When conducting an experimental project, agencies need to show that they are using the best information that is reasonably available to them at the time, document why they are doing what they are doing, use a logical process, and monitor the results and modify accordingly. This is because the agency may be required in the future to show that its design is reasonable, and the agency may not be able to cite a nationally published guideline or recommendation to support its local action. Often, these experimental projects are conducted because the design engineer has reason to believe that the new or evolved design will be safer or otherwise more effective for some purpose than if the prevailing standards and guides had been used. These



reasons or rationales are based on engineering judgment and should be documented to further minimize exposure to liability.

Unless otherwise noted, everything in these Guidelines can readily be adopted and incorporated. In addition, these Guidelines carry the credibility of the many transportation professionals who produced it.

In some cases, AASHTO design guidelines may not provide information on innovative or experimental treatments that have shown great promise in early experiments and applications. Since AASHTO is a design guide, agencies have some flexibility to use designs that fall outside the boundaries of the AASHTO guide. Deviation from the range of designs provided in the AASHTO guide requires agencies to use greater care and diligence to document their justification, precautions, and determination to deviate from the guidelines. In Florida, the precautions to establish “sovereign immunity” should be followed based on *Florida State Statute 768*.

Local agencies may currently use many other reports and documents to guide their roadway design and transportation planning. Other documents provide valuable procedure and reference data, but they do not set standards. They can be referred to and defined as standards by local agencies, but the local authority often has the flexibility to selectively endorse, modify, or define how these informational documents can be used or incorporated into its engineering and planning processes. Also, newer versions of these documents have additional information that can conflict with the local historical approach.

The expected results of the design approaches presented in this document are generally intended to improve safety and/or livability. As a result, implementation of these features should generally reduce liability and lawsuits. There is no way to prevent all collisions or lawsuits, but adopting policies, guidelines, and standards while performing experimental projects with reasonable precautions is a defensible approach.

## **HOW TO USE THE COMPLETE STREETS GUIDELINES MANUAL**

Since many local jurisdictions lack the resources to undertake a major revision of their manuals, this document offers a template for local jurisdictions to begin updating existing manuals. Local jurisdictions may use this document in any responsible way that helps them update their current practices, including adopting the entire *Broward Complete Streets Guidelines* and inserting the jurisdiction’s name into the text. They may also choose to adopt certain chapters in full or in part.

Local jurisdictions can use this document to assist with meeting the requirements of *Florida State Statute 335.065*, which requires transportation projects to consider bicycle and pedestrian improvements.



The *Broward Complete Streets Guidelines* manual is available to any local jurisdiction in Broward County that wishes to adopt or use it. The document is offered in a MS Word format to allow customization. The document’s sponsors ask local jurisdictions using it to do two things.

1. Keep the acknowledgements pages to recognize the people whose contribution made this manual possible and to carry the credibility of the authors with the document.
2. Inform the manual’s sponsors (via means described in the acknowledgements) that they have used the manual so the sponsors can track jurisdictions benefitting from it.

## ADOPTION AND IMPLEMENTATION

The *Broward Complete Streets Guidelines* is suitable for adoption by local and regional agencies to guide planning and design of streets. This adoption process allows agencies to indicate that the features and provisions of the plan are applicable for use by the adopting agency. This is a necessary first step in properly incorporating the provisions of the street manual. However, agencies will have to take additional steps to ensure that their implementation practices are modified to reflect the recommendations of this manual.

Local agencies will likely need to review their stepwise approach to street design through all stages of the process, from advance planning through preliminary design and construction. Critical points will include project identification, preliminary cost estimates for funding, and a multi-disciplinary approach to preparation of design drawings.

During adoption, as well as after adoption, local jurisdictions will need to ensure that their various departments are all operating with the same practices. These include entities such as but not limited to public works, traffic engineering, transportation planning, street services, maintenance, signal operations, street lighting, planning, redevelopment, fire, and other departments.

### Broward Complete Street Guideline Development Process

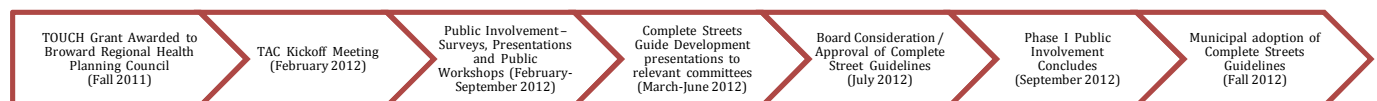

*Thanks to a Centers for Disease Control and Prevention (CDC) grant, the Broward Regional Health Planning Council and the Broward MPO have been able to support the development of the Broward Complete Streets Guidelines. Through intense community organization, it is hoped that these guidelines reflect Broward’s concerns, questions, and desires for Complete Streets. The above timeline illustrates the team’s timeline for adoptions of the Guidelines.*



## HOW THE BROWARD COMPLETE STREETS GUIDELINES DOCUMENT WAS CREATED

The *Broward Complete Streets Guidelines* document is based on the original work of the *Los Angeles County Model Design Manual for Living Streets*. The *Broward Complete Streets Guidelines* document is funded through a Transforming Our Community's Health (TOUCH) grant, which is part of the U.S. Department of Health and Human Services' Community Transformation Grants to support public health efforts to reduce chronic diseases, promote healthier lifestyles, reduce health disparities, and control health care spending. The Broward Regional Health Planning Council (BRHPC) is commended for their efforts as recipient and overall manager of the TOUCH initiative. The press release on the subsequent pages provides additional information and outlines the conditions and goals of the TOUCH initiative.

### BROWARD COMPLETE STREETS TECHNICAL ADVISORY COMMITTEE

Local officials in Broward County have modified this manual as appropriate for Broward-specific conditions, laws, regulations, standards, and policies. The Broward Complete Streets Technical Advisory Committee (TAC) was assembled to provide the technical assistance in preparing the document. In addition, the document was reviewed through the Broward Metropolitan Planning Organization (MPO) process.



*Broward Complete Streets TAC  
(Credit: Broward MPO)*



A complete list of the Broward Complete Streets Initiative Technical Advisory Committee (TAC) members is listed below:

- Alena Alberani, Sustainable Community Partners
- Scott Brunner, Broward County Traffic Engineering
- Paul Carpenter, City of Coral Springs
- Aylin Costa, Broward County Highway Construction and Engineering
- Andi Crawford, Broward YMCA
- Bill Cross, South Florida Regional Transportation Authority
- Heslop Daley, City of Fort Lauderdale
- Arlene Davis, Port Everglades
- Eric Dumbaugh, Florida Atlantic University
- Ellen Feiler, Broward County Department of Health
- Maribel Feliciano, Broward County Air Quality
- Jerry Ferguson, City of Deerfield Beach
- Pattie Gertenbach, Broward Bicycle/Pedestrian Advisory Committee
- Carolina Gutierrez, University of Miami – Miller School of Medicine
- Lori Hall, City of Miramar
- Ronald Kareiva, FDOT
- Gloria Katz, Smart Growth Partnerships
- Lynn Kunins, Florida Introduces Physical Activity and Nutrition to Youth (FLIPANY)
- Rick Labinsky, Hallandale Beach
- Michael Madfis, Community Involvement Roundtable/Smart Growth Partnership
- Amanda Martinez, City of Deerfield Beach
- John-Mark Palacios, FDOT Office of Modal Development
- Teina Phillips, Broward Regional Health Planning Council
- John Ramos, Broward County Transit
- Joy Riddell, AARP
- Jonathan Roberson, Broward County Transit
- John Rude, Broward Urban River Trails
- Peter Schwarz, Broward County Planning Council
- Richard Tornese, Broward County Highway Construction and Engineering
- Kevin Walford, City of Fort Lauderdale
- Ben Ziskal, City of Margate

Staff:

- Priscila Clawges, Broward MPO
- Anamarie Garces, Urban Health Partnerships
- Patrice Gillespie Smith, Urban Health Partnerships
- Mark Horowitz, Broward MPO
- Stewart Robertson, Kimley-Horn and Associates
- Christopher Ryan, Broward MPO



## Broward Regional Health Planning Council, Inc.

### CONTACT

Mike De Lucca, President and CEO

Office 954.561.9681

[MDeLucca@BRHPC.org](mailto:MDeLucca@BRHPC.org)

### FOR IMMEDIATE RELEASE

September 28, 2011

### **Broward Regional Health Planning Council Awarded \$1.76 Million to Help Create Healthier Communities in Broward County, Florida**

*Affordable Care Act to improve health in states and communities, which can control health care spending.*

Today, Broward Regional Health Planning Council (BRHPC) was awarded a grant of \$1.76 million for **Transforming Our Community's Health (TOUCH)** in Broward County, Florida.

This grant is part of the U.S. Department of Health and Human Services' (HHS's) Community Transformation Grants to support public health efforts to reduce chronic diseases, promote healthier lifestyles, reduce health disparities, and control health care spending.

Overall, HHS awarded approximately \$103 million in prevention grants to 61 states and communities, reaching more than 120 million Americans. The Community Transformation Grants will support the planning and implementation of state and community projects proven to reduce chronic diseases—such as diabetes, heart disease, stroke, and cancer.

**David Hughes, BRHPC Board Chair**, commented that “the efforts made by BRHPC and their partners to apply for a Community Transformation Grant demonstrates the level of support, collaboration and commitment our county has to address key health issues while serving the residents of Broward County.”

Nationwide, the Community Transformation Grants will focus on three priority areas: tobacco-free living; active living and healthy eating; and evidence-based quality clinical and other preventive services, specifically prevention and control of high blood pressure and high cholesterol. BRHPC will also address ways to create a safe built environment to complement active living and healthy eating. BRHPC is one of 35 across the country that was awarded an implementation grant. Broward County was the only grantee in Florida.

“Programs developed and supported through this Community Transformation Grant enforce the new realization that personal choice and action play a vital role in our long term health. Good health will only be attained by focusing on programs pertaining to prevention and healthy lifestyles thereby enabling individuals and families to experience a better quality of life” said **Sue Gunzburger, Mayor of Broward County**.



According to Health Foundation of South Florida **President and CEO, Dr. Steven E. Marcus**, “Health Foundation was actively involved in the BRHPC leadership team as we knew this award would help transform prevention to be at the forefront of impacting the health of the nearly 1.8 million residents.”

The grants are expected to run for **five years**, with projects expanding their scope and reach over time as resources permit. Specifically, the **TOUCH** initiative will include efforts to decrease exposure to tobacco use, improve policies and practices that increase access to healthy foods and physical activity across the County, increase the use of high-impact, quality clinical preventive services related to obesity, and implement strategies to create a safe built environment that supports many of the above strategies.

“This is great news that this crucial funding is on its way to South Florida,” said **U.S. Rep. Debbie Wasserman Schultz (FL-20)**. “In the United States, chronic diseases such as heart disease, cancer, and diabetes are some of the leading causes of death, disability, and health care costs, accounting for 75 percent of all medical costs each year. Although chronic diseases are among the most common and costly health problems in the country, they are also among the most preventable. I’m grateful to the Broward Regional Planning Council and all of its partners for their efforts to improve the health and well being of South Floridians.”

To learn more about Community Transformation Grants, visit [www.cdc.gov/communitytransformation](http://www.cdc.gov/communitytransformation).

###

---

Note: All HHS press releases, fact sheets and other press materials are available at [www.hhs.gov/news](http://www.hhs.gov/news)

915 Middle River Drive, Suite120, Fort Lauderdale, Florida 33304

[www.BRHPC.org](http://www.BRHPC.org)



## HOW THE ORIGINAL L.A. LIVING STREETS MODEL MANUAL WAS CREATED

As mentioned earlier, the original manual was a project of the Los Angeles County Department of Public Health called the *Los Angeles County Model Design Manual for Living Streets*. The department funded the production of this manual through a federal Communities Putting Prevention to Work grant to expand opportunities for people to bicycle and walk as an obesity prevention effort. The Luskin Center for Innovation at the University of California, Los Angeles, funded the chapter titled “Streetscape Ecosystem,” to address environmental sustainability issues related to streets.

A multidisciplinary team including many of the top street designers in the U.S. produced this manual. The team contained experts from traffic engineering, transportation planning, land use planning, architecture, landscape architecture, public health, sociology, and other backgrounds. The team also included experts serving in leadership roles for the following national and local organizations:

- AARP Public Policy Institute
- American Society of Landscape Architects
- Association of Pedestrian and Bicycle Professionals
- California Department of Health Services
- California Strategic Growth Council
- City of Long Beach
- City of Los Angeles Planning Department
- Council for Watershed Health
- Congress for the New Urbanism
- Federal Highway Administration
- Green Los Angeles Coalition
- Institute of Transportation Engineers
- Los Angeles Chapter of the American Institute of Architects
- Los Angeles County Department of Public Health
- National Complete Streets Coalition
- Project for Public Spaces
- Safe Routes to School National Partnership
- Smart Growth America
- UCLA Luskin Center for Innovation
- U.S. Access Board
- Walkable and Livable Communities Institute



*L.A. Living Streets Manual authors at charrette  
(Credit: Dan Burden)*

For a complete listing of all the contributors, please visit the Acknowledgements section of this manual.



## 2. VISION, GOALS, POLICIES, AND BENCHMARKS

INTRODUCTION.....	1
VISION.....	1
GOALS.....	2
POLICIES.....	2
CREATING A NEW SET OF BENCHMARKS .....	6
Benchmarks .....	6



*(Credit: Kimley-Horn and Associates, Inc.)*

## INTRODUCTION

The 31 municipalities of Broward County are a diverse collection of large cities and small towns, but each jurisdiction can benefit from safer, healthier streets that serve all users. This chapter establishes the vision, goals, policies, benchmarks, and performance measures for complete streets in Broward County.

## VISION

The intent of this manual is to describe how to properly design streets that adhere to a vision of complete streets in Broward County. It starts with the premise that any changes or improvements to streets should add value to the adjacent land and neighborhoods. Based on the feedback from the technical advisory committee members, the vision for Broward Complete Streets is outlined below. Complete streets...



*Ninth Avenue Complete Street in New York  
 (Credit: Bikes Belong Foundation)*

- Are designed for people of all ages and physical abilities whether they walk, bicycle, ride transit, or drive
- Integrate income, racial, and social equity into their design and function
- Integrate connectivity and traffic calming with pedestrian-oriented site and building design to create safe and inviting places
- Connect people through everyday interaction
- Engage their communities in designing “from the bottom up”
- Are inviting places with engaging architecture, landscaping, and public art that reflect the diversity and cultures of the neighborhood
- Foster healthy commerce
- Strengthen and enhance neighborhoods as envisioned by community members without displacing current residents
- Encourage active and healthy lifestyles
- Integrate environmental stewardship, water management, energy conservation, and preservation of plant life
- Vary in character by neighborhood, density, and function
- Are context sensitive
- Are intermodal
- Mitigate the climate of Southeast Florida



## GOALS

By establishing guidelines for local jurisdictions to create safer, healthier streets, the *Broward Complete Streets Guidelines* will promote the following goals.

- Provide transportation options for people of all ages, physical abilities, and income levels
- Serve the land uses that are adjacent to the street; mobility is a means, not an end
- Encourage people to travel by walking, bicycling, and transit, and to drive less
- Enhance the safety and security of streets, from both a traffic and personal perspective
- Provide increased opportunities for physical activity
- Create livable neighborhoods that connect communities, not divide them
- Reduce streetwater runoff into watersheds
- Maximize infiltration and reuse of stormwater
- Reduce greenhouse gas emissions and other air pollution
- Reduce energy consumption
- Promote the economic well-being of both businesses and residents
- Increase civic space and encourage human interaction
- Efficiently use the total amount of paved area to accomplish the above goals



*Walkable communities are livable communities*  
(Credit: Dan Burden)

***“Too much priority (is) given to cars and not enough to people. People should have the freedom to choose alternative modes of transportation and feel safe.”***

*-- (North Lauderdale Complete Streets Public Workshop participant)*

## POLICIES

Policies implement the vision and goals. Table 2.1 below aligns complete streets policies with the ten elements for complete streets established by the National Complete Streets Coalition. If local governments follow these policies, they will make progress toward meeting these goals and carrying out the vision of complete streets. Local governments should enact these policies through a complete streets ordinance or resolution.



*Multimodal street*  
(Credit: Toole Design Group)



**Table 2.1 Broward County Complete Streets Elements and Policies**

Complete Streets Elements	Complete Streets Policies
Vision	Local governments within the County will develop policies and practices that cause them to design their streets according to the Vision section in this Chapter.
All Users and All Modes	<p>Local governments will incorporate the full range of appropriate complete streets elements when planning and designing their transportation networks.</p> <p>Local governments will enhance the safety, access, convenience, and comfort of users of all ages and abilities. Local governments understand that children, elderly adults, and persons with disabilities will require special accommodations.</p> <p>Local governments will plan, design, and build high quality access and mobility for pedestrians, bicyclists, and transit passengers.</p>
Connectivity	<p>Local governments will design, operate, and maintain a transportation system that provides a highly connected network of streets that accommodate all modes of travel.</p> <p>Local governments will seek opportunities to repurpose rights-of-way, and to add new rights-of-way to enhance connectivity for pedestrians, bicyclists, and transit.</p> <p>Local governments will prioritize non-motorized connectivity improvements to services, schools, parks, civic uses, regional connections, and commercial uses.</p> <p>Local governments will require large, new developments to provide interconnected street networks with small blocks that connect to existing or planned streets on the perimeter of the development.</p>
Jurisdiction	<p>A local government’s complete streets policy document is intended to cover all roads, streets, and alleys in the jurisdiction.</p> <p>Every local government agency, including public works, planning, community development, street services, and others will follow the policies in this document.</p> <p>Local governments will require all developers to obtain and comply with their standards.</p>
Phases	<p>Local governments will apply their complete streets guidelines document to all appropriate roadway projects including those involving operations, maintenance, new construction, reconstruction, retrofits, repaving, rehabilitation, or changes in the allocation of pavement space on an existing roadway. This also includes privately built roads intended for public use.</p> <p>Complete streets may be achieved through single projects or incrementally through a series of smaller improvements or maintenance activities over time.</p> <p>Local governments will draw on all sources of transportation funding to implement complete streets.</p>



Complete Streets Elements	Complete Streets Policies
<p>Exceptions</p>	<p>Complete streets policies will affect all street construction, reconstruction, repaving, rehabilitation, and operations projects, except very specific conditions as established by an individual jurisdiction. Some suggested exceptions may include:</p> <ul style="list-style-type: none"> <li>A. A project involves only ordinary maintenance activities designed to keep assets in serviceable condition, such as mowing, cleaning, sweeping, spot repair, concrete joint repair, or pothole filling, or when interim measures are implemented on temporary detour or haul routes.</li> <li>B. The governing authority exempts a project due to an excessively disproportionate cost of establishing a bikeway, walkway, or transit enhancement as part of a project.</li> <li>C. The responsible employees within a local jurisdiction that manage engineering and planning jointly determine that the construction is not practically feasible or cost effective because of significant or adverse environmental impacts to waterways, flood plains, remnants of native vegetation, wetlands, natural features, or other critical areas, or due to impacts on neighboring land uses, including from right-of-way acquisitions.</li> <li>D. The responsible employee within a local jurisdiction that manages environmental resources issues a documented exception that application of complete streets principles is inappropriate for the surrounding environment.</li> <li>E. The responsible employee within a local jurisdiction that manages planning issues a documented exception where changes to the street may negatively impact the historical or cultural nature of the street or neighborhood.</li> <li>F. When a local jurisdiction is unable to influence the actions of the agency that has legal authority to operate and maintain the street.</li> </ul>
<p>Design</p>	<p>Local governments will adopt new complete streets design guidelines such as those contained within the <i>Broward Complete Streets Guidelines</i> to guide the planning, funding, design, construction, operation, and maintenance of new and modified streets while remaining flexible to the unique circumstances of different streets where sound engineering and planning judgment will produce context sensitive designs.</p> <p>Local governments will incorporate the street design guidelines' principles into all plans, manuals, rules, regulations, and programs as appropriate. As new and better practices evolve, local governments will incorporate those as applicable.</p> <p>Local governments will use street pavement widths as efficiently as possible to accommodate all modes of transportation, recognizing that allocating designated space by mode is preferred, but shared facilities may be the most practical solution in some cases.</p> <p>Local governments will provide well-designed pedestrian accommodation in the form of sidewalks or shared-use pathways on all arterial, collector, and local streets.</p> <p>Local governments will provide frequent, convenient, and safe street crossings. These may be at signalized intersections designed to be pedestrian friendly, or at locations not controlled by a traffic signal including unsignalized intersections and mid-block locations where needed and appropriate.</p>



Complete Streets Elements	Complete Streets Policies
	<p>Local governments will provide bicycle accommodation along all urban arterial and collector roadways with the goal of having a bicycle grid network with no more than ½ mile spacing between bicycle accommodations.</p> <p>Where physical conditions warrant, local governments will plant trees and manage streetwater whenever a street is newly constructed, reconstructed, or relocated.</p>
Context Sensitivity	<p>Local governments will plan their streets in harmony with the adjacent land uses and neighborhoods.</p> <p>Local governments will design their streets with full input from local stakeholders.</p> <p>Local governments will design their streets in harmony with natural features such as waterways, slopes, and preserves.</p> <p>Local governments will design their streets with a strong sense of place. They will use architecture, landscaping, streetscaping, public art, signage, etc. to reflect the community, neighborhood, history, and natural setting.</p> <p>Local governments will coordinate with merchants along Main Street corridors to develop vibrant retail districts.</p>
Performance Measures	<p>Street fatalities and injuries decrease for all age groups.</p> <p>The number and percentage of trips by walking, bicycling, and transit increases.</p> <p>Motor vehicle travel is reduced.</p> <p>Prevailing speeds of motor vehicles on urban streets decrease.</p> <p>Streetwater runoff is reduced.</p> <p>Water quality in rivers, canals, and the ocean improves.</p> <p>Retail sales and tourism increase.</p> <p>Resident satisfaction increases.</p>
Implementation Plan	<p>Broward County, municipalities, and local jurisdictions will adopt and apply a set of complete streets policies and the <i>Broward Complete Streets Guidelines</i>.</p> <p>Local governments will incorporate complete streets concepts into the next circulation element of their general plans.</p> <p>Local governments will either implement complete streets designs on every street, or initiate the process by preparing and adopting bicycle plans, pedestrian plans, green streets plans, Safe Routes to School plans, and an Americans with Disabilities Act transition plan.</p> <p>Local governments will prepare and adopt a storm water mitigation plan that intends to capture streetwater runoff on site.</p>



Complete Streets Elements	Complete Streets Policies
	In order to encourage the adoption of the <i>Broward Complete Streets Guidelines</i> , the Broward MPO will consider developing a policy giving priority to projects that follow complete streets principles.

## CREATING A NEW SET OF BENCHMARKS

Conventional street design applies auto-centric performance measures. The most common is the Level of Service (LOS), which seeks to maintain flow of motor vehicles and leads to widening streets and intersections, removing on-street parking, and other strategies to accommodate the flow of existing or future motor vehicle traffic. These techniques undermine the goals and tenets of complete streets.

To meet the goals and tenets of complete streets, Broward County and local jurisdictions should adopt the following benchmarks.

### BENCHMARKS

- Every street and neighborhood is comfortable for walking and bicycling.
- Every child can walk or bike to school safely.
- Seniors, children, and individuals with disabilities can cross all streets safely and comfortably.
- An active way of life is available to all.
- There are zero traffic fatalities.
- No unfiltered streetwater flows into local waterways or the ocean.
- Retail streets become one of the most popular destinations for tourists in the country.



*Crossing the street safely on a shopping trip  
(Credit: Kimley-Horn and Associates, Inc.)*



### 3. COMMUNITY ENGAGEMENT FOR STREET DESIGN

INTRODUCTION.....	1
COMMUNITY ENGAGEMENT AT THE BROWARD MPO.....	2
The Broward MPO Is Working With You .....	2
Please Get Involved.....	3
BROWARD COMPLETE STREETS INITIATIVE PUBLIC WORKSHOPS.....	3
ESSENTIAL PRINCIPLES OF COMMUNITY ENGAGEMENT.....	5
Develop a Plan .....	5
Accept Responsibility for Success .....	7
Start with a Base of Shared Values and Build Understanding.....	10
Broaden the List of Stakeholders.....	13
Foster Cultural Competence.....	18
Expect Emotional Connections—and Reactions—to the Built Environment.....	19
Approach Engagement as a Two-Way Conversation .....	19
Achieving Informed Consent .....	20
Carry the Momentum Forward.....	22
CONCLUSION .....	24
ADDITIONAL RESOURCES .....	24



*(Credit: Urban Health Partnerships, Inc.)*



## INTRODUCTION

Effective community engagement is critical when developing policies and projects that make a community’s built form more livable and more supportive of active transportation. There are many benefits of effective community engagement in projects influencing the built environment, be they urban, suburban, or redevelopment projects. The overall goal is meaningful community participation in the decision-making process.

Effective community engagement improves the success rates of policies and projects affecting the built environment because it helps the agencies and organizations leading a project understand and respond to local conditions. Agencies that create true community engagement are more successful at adapting to socio-economic changes that may influence the effort than those that do not conduct effective outreach (Cogan, E. and Faust, S., *Innovative Civic Engagement Tools and Practices in Land Use Decision-Making*, April 2010). When people affected by a project are involved from the beginning of the planning process, the likelihood of unexpected or significant opposition when it comes time to implement the project is reduced. Community members also have unique knowledge of local contexts, including political, cultural, and geographic settings. By interacting with the public and gaining local insight, project leaders can shape and direct the project in keeping with the community’s vision and needs.



*Public workshops should engage people in the planning process*  
 (Credit: Urban Health Partnerships, Inc.)

Effective community engagement also has the power to build social capital—the “social networks and interactions that inspire trust and reciprocity among citizens” (Leyden, K., “Social Capital and the Built Environment: The Importance of Walkable Neighborhoods,” *American Journal of Public Health*, 2003, 93[9]:1546–1551). A community with a high level of social capital is characterized by a culture of neighbors knowing each other, interest and participation in local politics, high rates of volunteerism, and diversity in social connections. These characteristics foster a sense of community, engender trust, enhance innovative problem solving, and increase the likelihood that stakeholders will support financial investments in community projects.

Research has demonstrated that a population can achieve long-term health improvements when people become involved in their community and work together to effect change (Hanson, P., “Citizen Involvement in Community Health Promotion: a Role Application of CDC’s PATCH Model,” *International Quarterly of Community Health Education*, 1988-89; 9[3]:177-186). Thus, even before projects are fully developed, creating a strong community engagement process



sets the community on a path toward improved health. Effective community outreach also helps address unequal access to health, including issues such as active living. Health equity, or the fair distribution of health determinates, outcomes, and resources regardless of social standing, is affected by factors such as poverty, housing, language, quality of education, and quality of healthcare. Through successful community outreach, people of all ages, backgrounds, and social standing are able to contribute to projects that support health and well-being. They also can help project leaders better understand how social, cultural, and economic barriers that impact historically disadvantaged communities are relevant to improving community health and well-being.

This chapter reviews principles and strategies to engage communities, including developing a plan for reaching out to communities, broadening the list of community stakeholders, fostering cultural competence, and achieving informed consent. It also provides an overview of the methods of community outreach used to garner input on these guidelines.

## **COMMUNITY ENGAGEMENT AT THE BROWARD MPO**

The Broward Metropolitan Planning Organization (MPO) conducts a thorough community engagement process about all aspects of metropolitan transportation planning. The MPO is a government agency responsible for transportation planning and funding allocation in Broward. The MPO works with the public, other governmental agencies, elected officials, and community groups to address transportation needs and develop funded transportation plans.

### **THE BROWARD MPO IS WORKING WITH YOU**

The Broward MPO wants to learn from your experiences, to help make the transportation decision making process the best it can be. The MPO knows that its decisions affect the future of all those who live, work, and play in our region. The MPO is committed to understanding your diverse transportation needs, concerns and ideas about what needs to be changed or be improved. Together we can make Broward County and the Southeast Florida region, a more livable place.

The Miami-Dade, Broward, and Palm Beach MPOs have developed an interactive web-based tool called the “**Transportation Outreach Planner**” available at the following website <http://mpotransportationoutreachplanner.org/> . The tool assists transportation planners and public involvement/information officers in the creation of effective public engagement programs and to accomplish Title VI goals by identifying the demographics of a community, selecting appropriate public outreach strategies based on that information, and learning about the area’s history and any challenges they may face.



## PLEASE GET INVOLVED

To learn more about Broward Complete Streets and other Transforming Our Community's Health (TOUCH) Initiatives, please visit [www.BrowardCompleteStreets.org](http://www.BrowardCompleteStreets.org).

Visit the MPO's website regularly at [www.BrowardMPO.org](http://www.BrowardMPO.org).

- Invite MPO staff to speak to your organization.
- Sign up to receive quarterly electronic newsletters.
- Complete a survey.
- Learn about the MPO Board and MPO Committees.

Or call and ask to speak to the Public Information Officer at [954-876-0033](tel:954-876-0033).

Plan to attend one of the MPO Board or Committee meetings. All meetings are open to the public and public participation is encouraged. Please visit the **Calendar Section** of the MPO website to see dates and times of upcoming meetings.

The Broward MPO Offices are located in the Trade Centre South Building at 100 West Cypress Creek Road, Suite 850, Ft. Lauderdale, FL 33309. For more information regarding directions and how to contact us, please visit the **Contact Us** section of the website.

For complaints, questions or concerns about civil rights or nondiscrimination; or for special requests under the Americans with Disabilities Act, please contact: Christopher Ryan, Public Information Officer/Title VI Coordinator at [954-876-0036](tel:954-876-0036) or [ryanc@browardmpo.org](mailto:ryanc@browardmpo.org).

## BROWARD COMPLETE STREETS INITIATIVE PUBLIC WORKSHOPS

The Broward Complete Streets Initiative held three public workshops in different areas of the county to generate public feedback on establishing complete streets community design standards to make our streets safe and healthy for all users. Concerned Broward citizens from all over the county attended to provide input to the process and learn more about how Broward County is joining communities across the country in rethinking road design and balancing rights-of-way for all users. Input received from the Broward Complete Streets Initiative workshops was incorporated throughout the *Broward Complete Streets Guidelines*. In addition, some of the key ideas and concepts heard from public workshop participants appear as notes in the individual chapters.

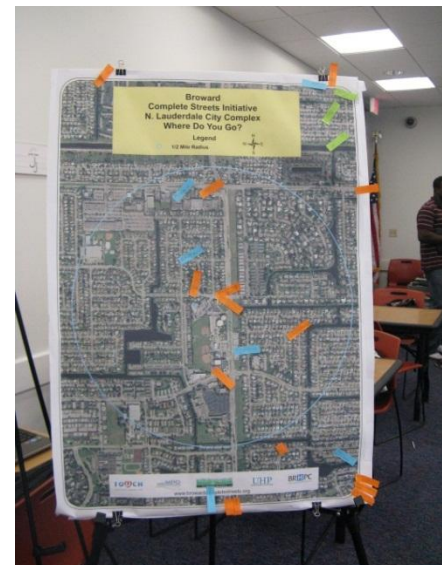

*Map from a Broward Complete Streets Initiative Workshop  
(Credit: Urban Health Partnerships, Inc.)*



Drop in for  
**FREE**  
Refreshments!

## BROWARD COMPLETE STREETS INITIATIVE

*Safer, Healthier Streets for ALL Users*

### Get Involved: Participate in a Public Workshop!

**Tuesday, April 17, 3-7 pm**  
*Northwest Broward*  
North Lauderdale City Complex  
701 SW 71st Avenue  
North Lauderdale, 33068

**Thursday, April 19, 1-3 pm**  
*Central Broward*  
NOVA University: Don Taft University Center  
3301 College Avenue  
Fort Lauderdale, 33068

**Wednesday, April 18, 6-8 pm**  
*Southeast Broward*  
Carver Ranches Public Library  
4735 SW 18 Street  
West Park, 33023



## BROWARD COMPLETE STREETS INITIATIVE

*Safer, Healthier Streets for ALL Users*



Do you like to bike?  
Do you like to walk?  
Wish you could walk and bike to more places in Broward?  
**Participate in the Complete Streets Initiative**  
Tell Us What You Think: Take our survey!  
Visit: [www.browardcompletestreets.org](http://www.browardcompletestreets.org) or scan this QR code.

Need more information? Visit [www.browardcompletestreets.org](http://www.browardcompletestreets.org)

This publication was supported by the Cooperative Agreement Award Number U58DP003661-01 from the Centers of Disease Control and Prevention. Its contents are solely the responsibility of the authors and do not necessarily reflect the official views of the Centers of Disease Control and Prevention.





## ESSENTIAL PRINCIPLES OF COMMUNITY ENGAGEMENT

A conventional model of “public involvement” has been built around complying with legal requirements for issuing public notices about projects and related events, holding public hearings to solicit feedback, and incorporating feedback into draft recommendations. The community has been invited in when project leaders have decided input is needed—or when it is mandated by law—and the public hearings, citizen advisory councils, and public comment sessions have formalized the effort. At many public meetings or events, a classroom structure communicates to people that they are to listen and not converse. This model fails to truly engage the public.

Given the many benefits offered by true community engagement, it is clear that project leaders, policy-making bodies, government agencies, health agencies, and community organizations have a special obligation to develop an inclusive approach to outreach. To engage communities, leaders must move from the conventional model to one that focuses on outreach, capacity-building, inclusiveness, and collaboration. Employing the following principles and strategies will help.

### DEVELOP A PLAN

Project leaders shouldn’t begin a public process without first developing a thoughtful and thorough community outreach plan that describes the desired outcomes of the project, and details the public process, including who the stakeholders and audiences are, how they should be reached, the messages to garner interest and tools that will be most effective in reaching them, and how the success of the effort will be measured. The plan should describe how outreach efforts will help build capacity, promote a shared language, illustrate project benefits, and inspire participation.

In general, community engagement activities need to address issues that the public perceives as important. Thus, while developing the community outreach plan, project developers should seek ways to explain to the public why the project matters. Additionally, efforts should be made to conduct workshops, events, or meetings in places that are comfortable and familiar to the audiences, and to use language that is clear. Each communication or event should contribute to the public’s understanding of the project and its purpose.

This chapter does not provide a template for a community outreach plan; it provides general guidance to help project leaders understand important principles and methods of achieving community engagement. With this guidance, a community outreach plan can be developed that utilizes best practices to accommodate local contexts and support community needs in working toward the goal of the project.

A community outreach plan should at the very least describe the project, the goals of the outreach effort (definition of success), identified issues, target audiences, messages that are



meaningful and relevant to the audiences, distribution channels, key messengers or speakers, resources available, tools, timelines, desired outcomes, and methods of evaluation and adjustment.

Specific outreach tools may include educational workshops, open houses, focus groups, citizen advisory committees, deliberative polling, media outreach, paid advertising, surveys, print materials (such as flyers and brochures), PSAs, educational videos, slide presentations, charrettes, newsletters, websites and other online communications, social media, direct mail, letters to the editor or guest commentaries, councils, speakers' bureaus, partnerships, coffeehouse chats, public meetings, multi-lingual comments cards, interviews, demonstrations, bulletin boards, and more.

***“Should have more workshops County-wide with more advertisement of the event”***

- *(Broward Complete Streets Public Workshop at NOVA Southeastern participant)*



*Public workshops should give participants the opportunity to fill out multi-lingual comment cards because some people fill more comfortable writing their ideas or would like to provide a written record of their ideas.*

*(Credit: Urban Health Partnerships, Inc.)*



ACCEPT RESPONSIBILITY FOR SUCCESS

Project leaders must take responsibility for developing effective and successful outreach programs that achieve identified goals. Too often, blame for a failed public process or event—one at which the turnout is disappointing, for example—is placed on public apathy. In many cases, though, the outreach effort was inadequate or misdirected. Sometime, the messages simply fail to convey why community members should care to participate in the process. For example, a conventional public notice may announce that the public is invited to a public hearing to comment on a proposed transportation plan. By contrast, a more meaningful outreach message would be that community members’ input is needed to shape the community’s future; the announcement would speak of streets, sidewalks, trees, and parks, would explain that transportation systems are integral to community-building, and would request residents’ help to determine what their community should become.

If truly effective community outreach was conducted and the public still showed little interest in the process, then the value of the project to the public must be revisited. If, on the other hand, project leaders understand the project truly is important and the public simply hasn’t engaged, then the effectiveness of the outreach effort must be revisited. Were the messages meaningful to the identified stakeholders? Were events held at convenient and comfortable times and places? Did people perceive the process as interesting, simple, important, or

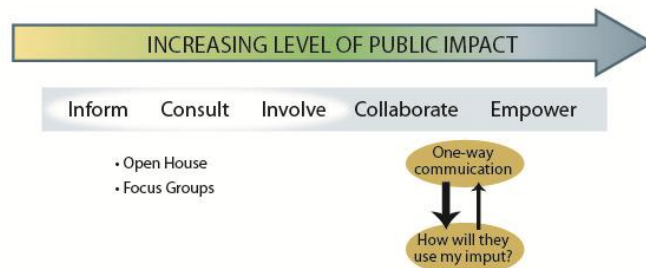
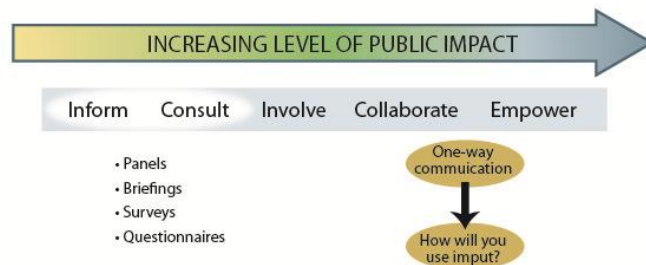



relevant to their lives? Did the messages even reach the target audiences?

A third consideration is that failure and success haven't been properly defined. For example, sheer numbers of participants may not be an appropriate measure of success. In a small community, an event turnout of 15 people who represent diverse interests, are truly interested in the project, and learn something from or contribute to the process may be a much more successful outcome than a roomful of 75 people who leave the event disengaged or who didn't find an opportunity to contribute in a meaningful way. Appropriately defining success and failure of a public process is an important part of developing a community outreach plan.

When defining success and failure, consider whether the community engagement effort should be designed to:

- **Inform:** community members are informed about the project but aren't actively involved in the process.
- **Consult:** the public is asked to provide feedback on analyses, alternatives, and decisions.
- **Involve:** feedback loops allow community members to influence multiple stages or drafts of the project.
- **Collaborate:** the public is a partner in each phase of the decision-making process and provides direct advice on solutions.
- **Empower:** the final decision is in the hands of community members and the project leaders will implement what the community chooses. Care is taken to ensure that the community is educated about approaches that work for all people, that key participants will help spread the word throughout the community, and that community members will play an active role when issues come before policy or decision-making groups such as councils and commissions.

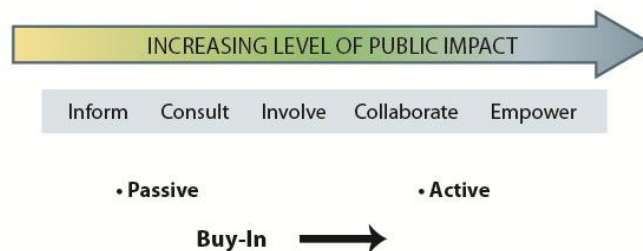
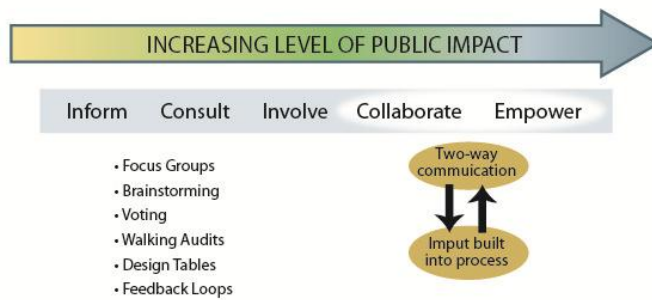

*(Credit: Michele Weisbart, adapted from the International Association for Public Participation)*



Outreach programs that most actively engage and empower the public also lead to the highest levels of buy-in and build the greatest support, which help alleviate some of the pressure on staff and elected leaders. The International Association of Public Participation (IAP2) created the graphic below to summarize the effective spectrum of the public participation process.

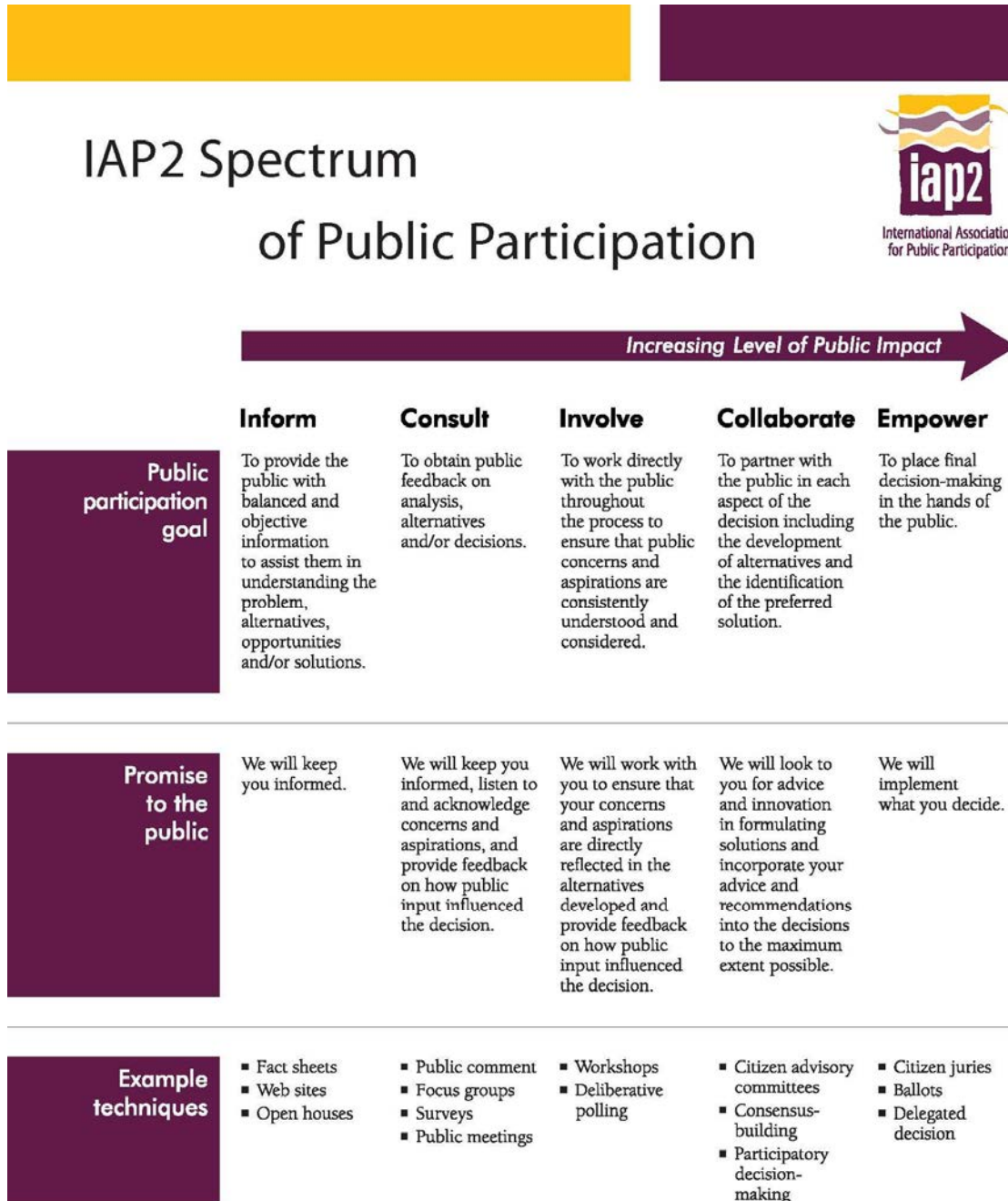



### START WITH A BASE OF SHARED VALUES AND BUILD UNDERSTANDING

The traditional model for public involvement in projects that affect the built environment often engages the public too late in the process, and in a manner that pits interests against each other.

A better model is to start the public process with visioning sessions or educational workshops that identify or clarify shared values. In some communities, a vision plan already exists and in those cases, the vision plan should help guide the project development. In other communities, a simple values-clarification exercise during an initial public workshop can go a long way toward helping stakeholders see that they generally want the same things for their streets—safety and security, economic development, attractive sidewalks, landscaping, and so on—and that their goal should be to collaborate on ways to achieve those ideals through the project being developed. Values clarification also can provide useful guidance to policy makers when trade-offs are concerned, for example, when the potential long-term effects of a decision are measured against short-term gains or losses. Starting with a base of shared values helps ensure outcomes aren't predetermined, but that the local vision is driving the process.

From this base of shared values, strive to build understanding and knowledge. Think like an educator, use language that is familiar and clear to the audience, and encourage reciprocal learning (learning from each other) and experiential learning (learning by doing or experiencing). Frame issues neutrally to maintain credibility and to ensure participants can make informed decisions. Facilitate well-informed and well-rounded discussions that ensure all voices are heard.



*Visioning sessions allow people to identify ways to guide a project's development.*  
(Credit: Urban Health Partnerships, Inc.)



*Public meetings should allow opportunities for people to voice their opinions.*  
(Credit: Dan Burden)



Toolbox: Active Workshops and Design Charrettes

The conventional format for public involvement usually doesn't build community interest, can be downright boring, and fails to capitalize on opportunities to build social capital through the process or engage people in reciprocal learning. Even workshop formats that aim to be more educational can fall short in efforts to build a shared understanding of the issues being addressed, or in making the participants feel truly engaged in the process.

Two tools being used by more and more communities throughout the country are active workshops and design charrettes.

Active, or experiential, workshops get participants out into the community to explore firsthand what shortcomings exist and how to improve upon those conditions. Active workshops include educational presentations, but focus on active learning and firsthand experience. Active workshops don't have to be long events. A successful one can be as short as three hours, if planned well.

Charrettes are collaborative sessions to solve design problems. Charrettes usually involve a group of designers working directly with participants to identify issues and create solutions. A charrette can be one day, several days, or weeks. A charrette conducted as part of a public process for a street should include educational activities (such as short presentations and walking audits, sharing of expectations and desired outcomes, priority setting, mapping exercises during which participants break out into small groups and mark-up maps with potential challenges and opportunities) and building consensus or informed consent for a proposed solution or set of solutions. Charrettes create a collaborative planning process that harnesses the talent of residents, townmakers, community leaders, and public health officials alike. At the end of the charrette, project leaders present the outcomes and findings to stakeholder groups and to the public.



*Design charrette engaging stakeholders  
 (Credit: Dan Burden)*

Getting all the right people together for a design charrette is essential to ensuring that the outcome reflects the values and goals of the community. People from all sectors of society with diverse backgrounds are needed at a charrette, including local government officials, planners and designers, landscape architects, transportation engineers, nonprofit managers, public health officials, and of course, residents.

Even with engaged and motivated participants from all relevant backgrounds, the charrette still may be missing a group that can provide valuable insight about how to design a healthier and



happier community: children. Children’s charrettes can bring valuable stakeholders in that might not otherwise be able to participate. They also provide the benefit of a unique perspective. The chief objectives in a children’s charrette are for it to be fun and engaging. Work with schools, parks and recreation departments, and parent/teacher associations to identify the best venue for engaging children and to conduct the needed outreach to ensure children attend. Also make sure children’s charrettes are age appropriate.

Effective active workshops and design charrettes help build social capital in the community. When people are taken outside of a classroom or presentation structure and are put in an environment, such as designing around tables or walking along streets to evaluate the built environment, where they can converse freely and naturally with others, many shared interests and connections emerge. This can foster partnerships that cross real or perceived boundaries, such as differences in generation, culture, socio-economic status, or geography. Effective workshops and charrettes often dedicate time toward the beginning of the events to help participants get to know each other through ice-breaking exercises that ideally will lead to long-lasting relationships.

Planning and conducting successful active workshops and design charrettes requires attention to the following details:

- **Engage key partners early.** Identify community-based organizations, government agencies, healthcare providers, employers, school boards, the media, and other organizations whose members or stakeholders may have an interest in the topic. Engage transportation, planning, emergency services, public health, and public works entities early in the planning process, and then enlist their help to conduct outreach and to issue invitations.
- **Choose the right audit site.** Work with the key partners to identify an audit site that captures the essence of changes needed throughout the community, or one that will have the greatest impact or has the potential to become a model project and serve as a catalyst for other projects.
- **Consider comfort and abilities.** Give careful consideration to participants’ comfort and abilities. Everyone who wishes to take part should be able to do so, and any special needs should be accommodated. Also, if the event is held during hot or cold months, conduct outdoor portions during the most comfortable time of day. Accommodate the needs of participants: for example, providing food allows working people to attend a 7 p.m. workshop; parents may need an organized play room for children too young to participate in the workshops.
- **Encourage relationship-building and provide a next step.** Effective workshops and charrettes will motivate and inspire those who take part, and many will be eager to contribute their energies toward enacting change. They will need to draw upon each other’s strengths, stay in contact, offer each other support, and share information to undertake the important work to be done. Encourage them throughout the event to network with each other and exchange contact information. If possible, form a “working group” and decide upon a first meeting date; invite people to opt in.



In particularly successful workshops and charrettes, project leaders can stand back and observe while residents pore over maps, draw meaningful new lines, find ways to improve access to healthy eating and active living, and generally work together toward a shared vision. Project leaders will need to provide technical guidance, but the community can and should make choices about the future together.

#### BROADEN THE LIST OF STAKEHOLDERS

To build effective community engagement, project leaders should broaden the list of stakeholders and partners whose involvement is sought. The overarching goal should be to achieve diversity by involving a demographically and geographically balanced group of people representing various interests and backgrounds.

Stakeholders and partners commonly include city and county staff, advocacy groups, residents, business operators, property owners, elected officials, community leaders, neighborhood safety groups, emergency responders, school representatives, health agencies, “Main Street” or downtown groups, charitable non-profit organizations, and regional employers. To be more effective, project leaders also should seek the early involvement of faith-based organizations, news outlets, potential opposition groups, and seasonal residents.



*Stakeholders should be active participants  
(Credit: Urban Health Partnerships, Inc.)*

In every community, there are people and groups that serve unique roles or have connections built on local context or events. Project leaders should determine who they are and invite them into the process early.



### Faith-Based Organizations

Across the country, churches, “build and sustain more social capital—and social capital of more varied forms—that any other type of institution” (*Better Together, The Report of the Saguaro Seminar: Civic Engagement in America*, Harvard University’s Kennedy School of Government, 2011). In small towns or areas of sprawl, churches, temples, and mosques often serve a major role in building community and capacity for change. Thus, project leaders should seek innovative ways to work with church leaders to engage their membership in public projects.

### Potential Opposition Groups

Special efforts should be made to identify and reach out to people and organizations that may be expected to oppose the project, to build their trust and involvement. Try to identify and address their concerns both as part of the public process and during special stakeholder interviews or meetings. This may include internal groups or professionals who initially may be inclined to provide technical brush-offs. For example, they may at the outset be worried that sanitation trucks won’t be able to maneuver on narrow roads, that trees may disrupt drainage, or that a crosswalk isn’t needed where people don’t already try to cross the road.

Whether internal or external, these concerns should be addressed early in the public process to give the potential opposition time to understand the project, become comfortable with proposed solutions, ask many questions, and decide whether to support the effort. Support is much more likely when these individuals and groups have been invited into the process early and have been included as key stakeholders. If participants feel as though the outcome is their plan, they are less likely to oppose it. By working side-by-side with other stakeholders, they learn to appreciate and accommodate others’ points of view.

Moreover, opposing groups often bring legitimate concerns to the design process. Through their involvement they can improve projects.

Seasonal residents are often ignored because they are sometimes not viewed as a true part of the community; they include condo residents, migrant workers, members of the military, and merchant marines. Although their members may not be able to attend public events in person, representatives of seasonal residents (including organizations such as migrant worker education groups, healthcare providers, homeowners’ associations, property managers, military officials, and operators of ports, marinas, and resorts) can become liaisons between their constituents and the project leaders, and are well-positioned to share timely and important information both ways.



### Children

Children have much to offer in the community planning and design process, yet they remain mostly untapped throughout community transformation processes. A child's imagination is a powerful tool; children can dream the perfect community in which to live, play, and go to school. Beyond the power of their imaginations, they can also bring very practical solutions to the table. For example, children are often aware of shortcuts that could be formalized into trails and added to the community's pedestrian network map. Their values and honesty helps raise the discussion to the level of



*Public workshops should engage all groups, including children  
(Credit: Broward MPO)*

guiding principles; the involvement of children in public processes can change the whole tenor of the event. Engage children through children's charrettes, art or urban design contests, school field trips, and special activities at community charrettes or workshops. Invite them on walking audits near their schools. At the very least, provide schools with flyers announcing the project or public process that can be sent home with children in their bags.

### Toolbox: Media Outreach

Conducting effective outreach to news outlets is important to the success of any community engagement effort. The news media are more than simply a means to get the word out about the project. Rather, project leaders should try to build capacity among news organizations, just as the outreach effort seeks to build capacity among community members; building relationships with reporters helps ensure the general public is receiving accurate, timely, and meaningful information about the project.

The lead agency's communications department should be consulted to provide guidance, expertise, and tools, but project leaders should remain very engaged in the media outreach effort. Project leaders should be committed to working within the agency's communications protocols, such as complying with a gatekeeper policy if one exists. If a communications department isn't available, the following paragraphs provide general guidance.



# BETTER BLOCK

FORT LAUDERDALE, FL

FLAGLER  
VILLAGE



NW 1st AVE 500 BLOCK  
between NW 5th and 6th Streets

A LIVING CHARENTE

presented by Cadence + FAU School of Urban and Regional Planning + FAT Village Arts District

JUNE 16, 2012 10:00 AM  
- 6:00 PM



**Better Block** is an urban design exhibit, demonstrating how temporary streetscape improvements, pop-up businesses, local culture, and street life can improve community connection.

DEMONSTRATE.

EDUCATE.

CONNECT.



Better Block - NW 1st Ave.  
FORT LAUDERDALE.

Cadence. April 2012.

\*Experience a shared street, where the automobile, the bike, the pedestrian and businesses utilize the street space together.

To help us build a BETTER BLOCK

email: [BetterBlockFtL@cadence-living.com](mailto:BetterBlockFtL@cadence-living.com)

follow the movement

f [facebook.com/BetterBlockFtL](https://www.facebook.com/BetterBlockFtL)  
#BetterBlockFtL  
w [betterblock.org](http://betterblock.org)



Example of a promotional flyer announcing an event  
(Credit: Cadence and Florida Atlantic University)



### **Call Key Outlets Early**

As soon as the project kickoff is confirmed or possibly even earlier, call—don't email, fax, or send a letter—key reporters to share the purpose of the project and to ask them how best to provide more information when it is available. Keep a list of the contacts made and how they would like to receive additional information; then, be sure to follow up in that manner.

Depending on the news organization and its depth and structure, special effort should be made to reach transportation, public safety, and health and business reporters. Contact the primary news sources in local and regional markets, but don't overlook non-traditional news sources, such as blogs that cater to cyclists or that address transportation, public safety, community health, retirement, and business issues. Any key reporters—regardless of their medium—should be contacted as soon as possible by phone.

Also, offer to submit a guest commentary in advance of the project kick-off or to secure a prominent guest for an upcoming talk show. If the project may be especially controversial, try to schedule an editorial board meeting with the local or regional paper.

### **Issue Meaningful News Releases**

Develop a news release that is engaging and written in the form of a news story. Be sure to include the five W's—who, what, why, when, and where. Describe the goal of the project, how people can become involved, and any other information that will help make the story meaningful and relevant to the local and regional audience. Include keywords to ensure the news release and its contents can be easily found online. Distribute the news release initially to the key media outlets already contacted, and be sure to provide it in the manner they requested (check the list made during the initial conversations). Then, distribute the news release to all other media outlets in the region. Also, consider including non-traditional news sources in the media outreach strategy.

Finally, distribute the news release to local partners and other local contacts, asking them to share it with their media contacts. The value of the relationships the local partners already have with media contacts shouldn't be overlooked; tap into that value by supporting the local partners in their efforts to conduct media outreach for the benefit of the workshop and related efforts.

### **Be Responsive and Keep in Touch**

As project leaders build relationships with news sources, they should expect to receive more and more inquiries. Understand that reporters often are working on very tight deadlines; sometimes they receive story assignments mid-day with evening deadlines. Be responsive and provide timely information to help ensure accurate details are relayed to news audiences and to further support the relationship with the reporter. Additionally, be proactive in sharing news about project developments or milestones being met; doing so will further build capacity amongst the news sources, help keep them engaged in the project, and support the dissemination of timely and accurate information.



### Media as Stakeholders

Conventional community outreach plans have treated the media as a means of simply disseminating information. A more effective approach is to engage members of traditional and non-traditional news outlets alike (newspapers, television, radio, online news services, bloggers, etc.) as stakeholders and seek their involvement early in the process. Just as project leaders should build capacity amongst residents and within the community, so too should they seek to build capacity with journalists and news outlets. The media can also help projects move forward with positive editorials and favorable reporting.

### FOSTER CULTURAL COMPETENCE

Ensuring that programs and messages are designed to be relevant, appropriate, and effective in different cultures and different languages is vital to conducting successful community outreach. In fact, cultural competence has emerged as a key strategy to improving health and the quality of healthcare and social services for everyone in the U.S. regardless of race, ethnicity, cultural background, or language proficiency.

Translating important messages requires strong cultural knowledge, because “simply replacing one word with another won't do” (Zarcadoolas, C. and Blanco, M., “Lost in Translation: Each Word Accurate, Yet...,” *Managed Care Magazine*, August 2000). But reaching people of all backgrounds often requires more than simply translating messages. Even in urban communities, but especially in rural areas or small towns, messages perceived to have been created by “outsiders” can actually do more harm than good by creating discomfort or mistrust.



*Stakeholders share the planning responsibility  
 (Credit: Ryan Snyder)*

To increase their effectiveness, many organizations working with multi-cultural populations are developing “ambassador” programs that recruit people who live in and work in a community to be community educators and liaisons between the project or program and the community. Other communities are working to culturally adapt messages, instead of simply translating them, to focus on types of behavior changes that would be relevant and appropriate in the cultural context of the different audiences.



When culturally adapting messages, consider the following:

- Language doesn't equal culture. Although a shared language is important to culture, people who speak the same language often are from different cultures. Be sensitive to the differences and develop appropriate messages.
- Start with strong cultural knowledge. Tap the knowledge of in-house staff or consultants who live, work, or grew up in the culture.
- Get feedback. Work directly with members of the audience to determine appropriate approaches. Use focus groups to screen messages before they are distributed.

#### EXPECT EMOTIONAL CONNECTIONS—AND REACTIONS—TO THE BUILT ENVIRONMENT

People have strong emotional connections to their built environments, and those feelings influence involvement in community-building efforts. The structures and infrastructure around people create strong frames of reference for daily living and help build comfort, a sense of security, and a sense of belonging.

Place attachment is a notable part of daily life. Project leaders should anticipate that responses to projects may be emotional, but those responses shouldn't be dismissed as invalid; they should be addressed as valuable input.

#### APPROACH ENGAGEMENT AS A TWO-WAY CONVERSATION

Effective public engagement involves more than telling people about a project; effective engagement facilitates a dialogue that leads to reciprocal learning, collaboration, and ideally, consensus.

Community members have unique knowledge of local contexts that will affect the outcome of a project development process. By engaging in reciprocal learning, project leaders will gain insight and perspective that can help them ensure the project is tailored to meet the community's needs. Community members also will learn from each other.

An effective public process results in people feeling that they are well-informed and that they've had opportunities to contribute throughout the stages of decision-making.



*Product of a design charrette (Credit: Ryan Snyder)*

“In fact, what appears to be most important from a citizen's perspective and from the standpoint of attaining ongoing engagement is not the strategy employed, but how



government responds when citizens voice their preferences. For citizens, there are two questions that are paramount: Did the government listen and take action based on what they heard from us? Was it worth my time and effort?" (*Connected Communities: Local Government as a Partner in Citizen Engagement and Community Building*, Alliance for Innovation, Oct. 2010).

In addition to workshops, project leaders can seek community input through interactive online tools such as websites, digital storytelling, and community mapping. In communities with many seasonal residents, these tools can be especially useful in collecting input from stakeholders who aren't able to attend events in person.

Digital storytelling allows the public to use photos and presentation tools to illustrate concerns about the built environment. Many communities are starting to use this "photo voice" approach to encourage community members to present their points of view using photographs and descriptions or narration. The package can be submitted electronically to project leaders or presented as part of a public workshop or event.

#### ACHIEVING INFORMED CONSENT

The goal of informed consent is not compromise, where everyone must give up something.

Informed consent is based on the assumption that most people will give their consent to a change, even when it is not in their personal best interest, after they have been engaged, become informed, and see the value to their community. Although this requires altruism, there are many reasons why it succeeds other than people wanting to leave something behind as a legacy. Working cooperatively, all people achieve more, and so enlightened self-interest wins, once people understand why an idea is good for their neighborhood.



*Stakeholders designing their streets  
(Credit: Dan Burden)*

The steps of the informed consent process are as follows:

- **Desire.** The public process comes about as a result of a community coalescing around a desire for a change in its built form. Though desire comes in different forms, it is the



necessary energy and often passion used to steer the project towards a sustainable and community-oriented outcome.

- **Discovery.** Discovery is the process of developing a complete and common understanding of the situation, context, and the built vision by the design team and the stakeholders. Context is a short form for the physical, social, historical, fiscal, environmental, political, and climatic contexts. Good discovery is done by:
  - Listening, looking, and involving people
  - Visiting, reading, and probing
  - Educating and exploring physically and intellectually
- **Design.** Design is the employment of people, their related skills, and what they discovered to produce products that articulate, memorialize, and motivate people towards the consensus outcomes and the vision. It tends to be the most exciting part of the process. This is when collaborators can raise the bar in terms of creativity and sustainability.

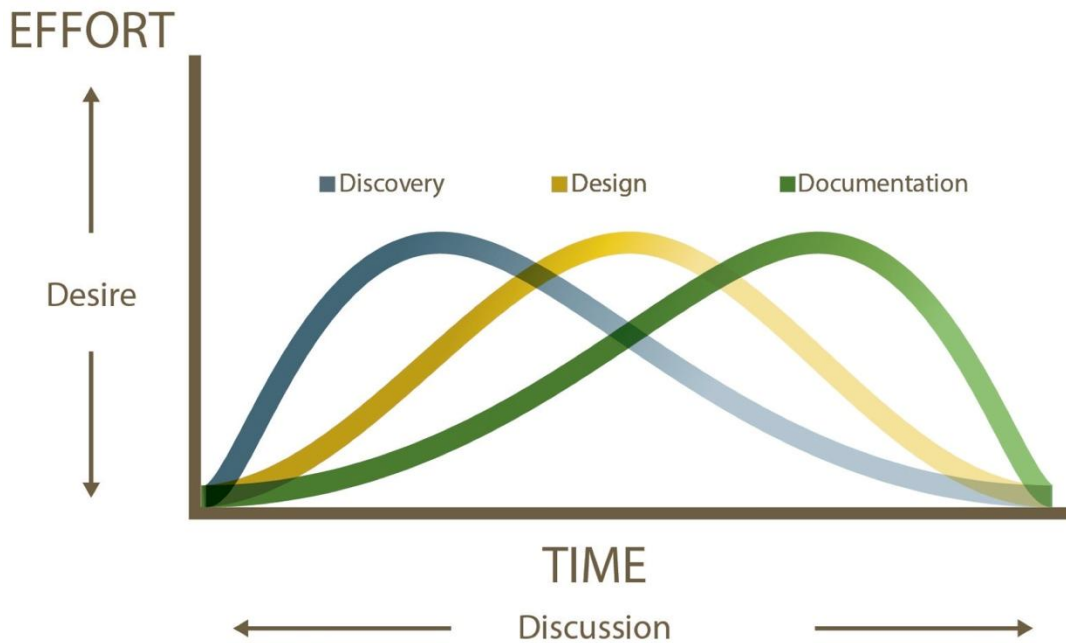

*Steps of the informed consent process  
 (Credit: Michele Weisbart, adapted from Ian Lockwood)*

- **Discussion.** Discussion happens throughout and requires the right people/stakeholders with the capabilities present at the right times in order to maximize short feedback loops. It is the discussion phase that builds and overcomes uninformed decision making. If grassroots planning is to work, people must become informed on what helps build a community. With the combination of a strong desire and community leadership the sense of frustration will be overcome, but this must come with an informed neighborhood. Discussion involves:
  - A series of presentations to raise stakeholders' knowledge.



- Testing/viewing the design and parts of the design from a variety of perspectives.
- Circling back to alter parts that need altering.
- The project manager must prepare the community to "sell" its vision to others. True ownership of a vision comes from within.
- **Documentation.** Documentation starts at the beginning of the project but the effort is highest towards the end when the products are finalized. Example products include documents, posters, codes, speeches, agreements, construction drawings, and advice. This documentation works best when designers anticipate pushback. Messages must be clear, concise, comprehensive, and attractive to draw people in.

### CARRY THE MOMENTUM FORWARD

Successful community engagement often leads people to become motivated and ready to mobilize to enact positive change. Project leaders should capitalize on this energy and help form long-lasting coalitions by organizing a working group or advisory council that will help carry the momentum forward. The members of the group should represent diverse interests and backgrounds and should be committed to continuing to communicate with each other and meeting regularly to address the issues identified through the project development process. The group can be established to provide guidance and continuing community feedback to project leaders as implementation begins.

Celebrating early successes helps ensure long-term project success. When project implementation begins, identify an early achievement and widely publicize the success; this can even be the project's public process itself. Consider holding a special event that will publicize the new community asset, bring recognition to the people involved, reaffirm that the process has worked, and build more support for work to be done. For example, the completion of a trail or trail segment could be celebrated with a special family fun run/walk held in conjunction with a ribbon-cutting ceremony and press conference. Widely celebrating projects like these helps people in nearby communities envision how they can improve their neighborhoods as well.



*Community celebrates and supports their achievements  
(Credit: Michael Ronkin)*



### Toolbox: Strategies for Implementation

The following strategies can be helpful in implementing projects:

- **Secure and leverage the support of key partners early.** They may be members of the chamber of commerce, influential elected leaders, chief planners of agencies, or community advocates. Leverage their support by ensuring other key partners are aware of their buy-in.
- **Use data appropriately.** Too many towns don't implement projects because they lack data, or conversely, they rely on it too heavily. Presented with too much, people may argue over its meaning, leading to projects not being built and community members losing trust in project leaders. Some data is needed to ensure the context is properly understood. Thus, conducting research to collect basic data is necessary, but street design projects also should be driven by commonly held values in the community.
- **Build model projects.** Model projects can be examples of how streets can work better, especially when building something that is new for the community, such as a non-conventional crossing, a road diet, reverse-in angled parking, mini-circles, or roundabouts. Build model projects first in areas with strong backers and the greatest chances for success. If the vision is to have modern roundabouts in a dozen locations, start with the location with the most enthusiasm and support. Enlist local leaders to attend meetings, submit letters to the editor, and conduct other outreach that explains why the neighborhood wants the new feature.
- **Evaluate built projects.** Don't just build a project: evaluate it. For example, a 30 percent increase in people walking, 20 percent more bicyclists, a reduction in vehicle speeds of 7 mph, 120 column inches of positive newspaper coverage, and other metrics can validate the project and build support for similar projects. Use other performance-based measures to evaluate success not only of the project, but also of the public process that led to it. Evaluations can assess the assumptions and the planning processes that lead to changes. Assessment of the planning process includes evaluations of how well the project performed. Evaluation can include the following:
  - Did the project meet the commonly-held community vision?
  - Important projects that benefit all members of the community are the first to be built. Did those built reflect the community's priorities?
  - Did the project provide long-term benefits to all people?
  - Did the process allow for adequate time to respond to plans?
  - Were there any legal actions or complaints about the public process that could have been reduced or eliminated?
  - How can the public process improve?



## CONCLUSION

Creating successful community engagement through effective outreach is a significant investment of resources, but many of those resources already exist in-house and simply need to be committed to the effort. For policy-making bodies, government agencies, health agencies, and community organizations that understand the value, benefits, and processes of creating successful community engagement, the effort provides a clear return on investment.

## ADDITIONAL RESOURCES

Betancourt, J., Green, A., Carrillo, J.E. and Park, E.R. "Cultural Competence and Health Care Disparities: Key Perspectives and Trends." *Health Affairs*, 2005, 24(2):499-505.

Ikemoto, L. "Racial Disparities in Health Care and Cultural Competence." HeinOnline 48 St. Louis U. L. J. 75 (2003-2004).

Tri-County (Colorado) Health Department and Communities Putting Prevention to Work. *Built Environment and Health Handbook*. January 2011.

Manzo, L. and Perkins, D. "Finding Common Ground: The Importance of Place Attachment to Community Participation and Planning." *Journal of Planning Literature*. May 2006, 20(4):335-350.

Federal Highway Administration. "Public Involvement Techniques for Transportation Decision-Making." <http://www.fhwa.dot.gov/reports/pittd/charrett.htm>



## 4. STREET NETWORKS AND CLASSIFICATIONS

INTRODUCTION.....	1
The Link To Safety .....	1
The Link To Transportation Mode Choice .....	2
The Link To Emergency Response.....	2
The Link To Economic Activity .....	3
The Link To Healthy Communities .....	4
ESSENTIAL PRINCIPLES OF SUSTAINABLE STREET NETWORKS.....	5
APPROACH.....	6
CONNECTIVITY INDEX.....	6
STREET CHARACTERISTICS AND CLASSIFICATIONS .....	6
Context: The Transect .....	8
DESIGN STANDARDS.....	9
Types and Roles of Streets.....	11
ADDITIONAL RESOURCES .....	17



*(Credit: Kimley-Horn and Associates, Inc.)*



## INTRODUCTION

This chapter describes the inter-relationship between the broader network of streets, how streets are classified, and how this affects the experience of the network user. Principles of complete streets are presented in the planning for urban street networks to create a well-connected grid that provides a high degree of route choices and transportation modal options. A well-connected grid network of streets is called a sustainable street network. The consideration of complete streets principles in the network and corridor planning processes contributes to the consideration of key issues and objectives.

The United States has a long and distinguished history of creating memorable and enduring cities, such as Savannah, Charleston, Washington, D.C., Boston, Santa Monica, and San Francisco. These cities are memorable and enduring partly because of their street networks. Well-planned street networks help create sustainable cities that support the environmental, social, and economic needs of their residents.

*“There are no obstacles to getting around, if you have a car “*

*- (Participant in Broward Complete Streets focus group with the elderly)*

The street network configuration affects three fundamental aspects of urban transportation.

- Safety
- Transportation mode choice
- Emergency response

## THE LINK TO SAFETY

- **Sustainable street networks improve traffic safety.**

Over 30,000 Americans perish each year in traffic crashes (National Highway Traffic Safety Administration, Fatality Analysis Reporting System [FARS], 2009 data). Pedestrians account for a significantly higher percentage of fatalities than their typical mode share would indicate (4,092 pedestrians died in traffic crashes in 2009, which represented 12.1 percent of all traffic fatalities). Bicyclists (termed pedalcyclists in the FARS database) are also overrepresented (630 bicyclists died in traffic crashes in 2009, which represented 1.9 percent of all traffic fatalities). A good street network is a powerful tool for reducing traffic crashes and fatalities while creating beautiful places.

Hierarchical street patterns (arterial-collector-local) with cul-de-sac subdivisions depending on arterials do not perform as well as sustainable street networks and cause more traffic crashes. Hierarchical street networks divert traffic to high-speed arterials that have large intersections. Most motor vehicle crashes occur at intersections. Even short, local trips must use arterials because there is not a supporting network of connected collectors and local streets. The speed at which motor vehicles move on these arterial streets increases the likelihood and severity of crashes.



A 2011 study of 24 California cities found a 30 percent higher rate of severe injury and a 50 percent higher chance of dying in cities dominated by sparsely connected cul-de-sacs compared with cities with dense, connected street networks (Marshall, W. and Garrick, N., “Does the Street Network Design Affect Traffic Safety?” *Accident Analysis and Prevention* 43[3]: 769-781). A 2009 study from Texas found that each mile of arterial is associated with a 10 percent increase in multiple-vehicle crashes, a 9.2 percent increase in pedestrian crashes, and a 6.6 percent increase in bicyclist crashes (Dumbaugh, E. and Rae, R., “Safe Urban Form: Revisiting the Relationship between Community Design and Traffic Safety,” *Journal of the American Planning Association* 75[3]:309-329).

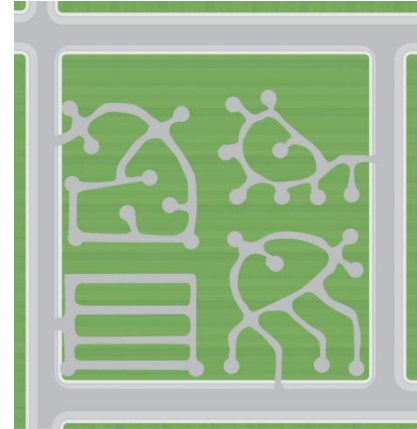

*Cul-de-sac developments break up connectivity and create longer trips  
 (Credit: Michele Weisbart)*

THE LINK TO TRANSPORTATION MODE CHOICE

- **Sustainable street networks increase the number of people walking, bicycling, and taking transit, which help reduce vehicle miles traveled.**

Connectivity enables people to take shorter routes. It also enables them to travel on quieter streets. These shorter routes on quiet streets are more conducive to bicycling and walking. The California study cited above found that places with a dense, connected street network had three to four times more people walking, bicycling, or using transit to get to work. This in turn led to a 50 percent reduction in vehicle miles traveled per capita in these cities (Marshall, W. and Garrick, N., “*The Spatial Distribution of VMT Based upon Street Network Characteristics*,” 90<sup>th</sup> Meeting of the Transportation Research Board, Washington, D.C., January 2011).

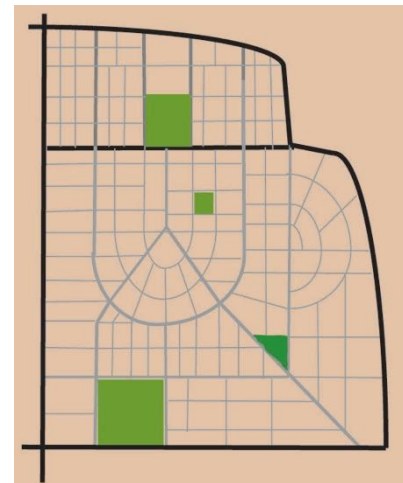

*Interconnected street network  
 with small blocks  
 (Credit: Marty Bruinsma)*

THE LINK TO EMERGENCY RESPONSE

- **Sustainable street networks allow more effective emergency response.**

Two primary reasons why sustainable grid street networks work better for emergency response are (1) maximizing the number of addresses served from each station and (2) providing a redundancy of routes. Studies in Charlotte, North Carolina, found that when one connection was added between cul-de-sac subdivisions, the local fire station increased the number of addresses served by 17 percent and increased the number of



households served by 12 percent. Moreover, the connection helped avoid future costs by slowing the growth of operating and capital costs; most of the cost to run a fire station is in salaries. Furthermore, the Congress for the New Urbanism's (CNU) report on emergency response and street design found that emergency responders favor well-connected networks with a redundancy of routes to maximize access to emergencies. Emergency responders can get stuck in culs-de-sac and need options when streets back up ("*Effect on Connectivity on Fire Station Service Area and Capital Facilities*," 2009 presentation by the Charlotte, North Carolina Department of Transportation, <http://charmeck.org/city/charlotte/citymanager/CommunicationstoCouncil/2009Communications/Documents/CNUPresentationcolor.pdf>).

In addition to transportation benefits, broader Smart Growth goals such as economic activity and healthy communities are supported by sustainable grid street networks.

#### THE LINK TO ECONOMIC ACTIVITY

- **A sustainable and resilient street network fosters economic and social activity.** While the number of lanes on each street are limited, maximum travel options (routes) are enhanced by sustainable street networks because collectively, more lanes are provided on more streets with better connectivity. By providing opportunities for all modes of travel, an ideal street network enhances social equity and provides an ideal setting for high quality design at all scales: building, neighborhood, and region. The resulting communities can be some of the most beautiful places with the highest values in the world.

An excellent local example of this principle is the Las Olas area of Fort Lauderdale. Las Olas was developed in the 1920s when communities were still developed around a grid street network. Local real estate studies consistently find that the Las Olas area enjoys the most resilient and sustainable values in Broward County. Commercial lease rates in Las Olas remain at a premium and Las Olas has surpassed Broward Boulevard as the premier address for office users ("*Year End 2011 Broward Office Report*," Commercial Florida Realty Services, LLC). According to this report, new office space is not likely to be developed in the central business district for the foreseeable future; however, planned development of multi-family residential could actually spur more activity resulting in even higher demand for office space. This demonstrates the positive impact of mixed-use areas.

Affordable housing also benefits from a sustainable grid street network. Affordable housing developments are often located in older neighborhoods with at least a partial grid street network in place. This allows residents to take advantage of the transportation benefits offered by shorter walks to work or public transportation, and being able to bicycle on connected local streets and collectors, rather than arterial boulevards. In addition, a recent report from the Center for Real Estate at the Massachusetts Institute of Technology (MIT) debunks the notion that affordable housing



developments depress the values of nearby single-family dwellings. Using data from 36,000 property sales between 1982 and 2003, the researchers found that home value changes over time in the areas near affordable housing developments simply “tracked” those in nearby market areas with no affordable housing options (Pollakowski, H., Ritchay, D., and Weinrobe, Z., “*Effects of Mixed-Income, Multi-Family Housing Developments on Single-Family Housing Values*,” April 2005).

#### THE LINK TO HEALTHY COMMUNITIES

- **A sustainable and resilient street network enhances active transportation and community vitality.**

The health benefits of a traditional grid street network, which enhances connectivity and active transportation options, are numerous. Street network designs impact the likelihood residents will engage in walking, bicycling, or wheeling (physical activity) as a mode of active transportation. Active transportation can reduce the risk of diseases impacted by sedentary lifestyles, including Type 2 Diabetes, heart disease, high blood pressure, stroke, dementia, breast and colon cancer, as well as those related to poor air quality such as impaired lung development, lung cancer, and asthma, among others (Buchman, A. S., et al., “Total Daily Physical Activity and the Risk of AD and Cognitive Decline in Older Adults,” *Neurology*, 2012, 78: 1323-1329; Lee, C. D., Folsom, A. R., and Blair, S. N., “Physical Activity and Stroke Risk: A Meta-Analysis,” *Stroke: Journal of the American Heart Association*, September 18, 2003, 34: 2475-2482, available at <http://stroke.ahajournals.org/content/34/10/2475.full.pdf>; Bell, J. and Cohen, L., *The Transportation Prescription: How Transportation Policies and Plans Influence Health*, PolicyLink and Prevention Institute, 2009, available at <http://www.policylink.org>; Frank, L. D., Andresen, M. A., and Schmid, T. L., “Obesity Relationships with Community Design, Physical Activity, and Time Spent in Cars,” *American Journal of Preventive Medicine*, 2004, 27[2]: 87-96; Slattery, M. L., et al., “Energy Balance and Colon Cancer — Beyond Physical Activity,” *Cancer Research*, January 1, 1997, 57[1]: 75-80; and U.S. Department of Health and Human Services, *Physical Activity and Health: A Report of the Surgeon General*, 1999, available at <http://www.cdc.gov/nccdphp/sgr/index.htm>).

Residents living along a sustainable street network are more likely to have higher levels of social capital (know their neighbors, participate politically, trust others, and be socially engaged) than those residing along car-oriented suburbs (Leyden, K. M., “Social Capital and the Built Environment: The Importance of Walkable Neighborhoods,” *American Journal of Public Health*, September 2003, 93[9]: 1546-1551). These are vital components contributing to mental health and well-being of the community, as well as the opportunity for residents to age in place (Cagney, K. and Wen, M., *Social Capital and Health: Part II Chapter 11. Social Capital and Aging-Related Outcomes*, 2008, 239-258). Additional benefits of such cohesion produced by gridded street networks include more eyes on the street, which provides support, safety, and reduction in violence (Cohen, L. et al., *Addressing the Intersection: Preventing Violence and Promoting Healthy Eating and Active Living*, Prevention Institute, 2010, available at [www.preventioninstitute.org](http://www.preventioninstitute.org)).



Disparities in affordable transportation access can also be addressed by a sustainable street network (TransForm in collaboration with the California Department of Public Health, *Creating Healthy Regional Transportation Plans: A Primer for California's Public Health Community on Regional Transportation Plans and Sustainable Communities Strategies*, 2012, available at [www.transformca.org](http://www.transformca.org)). Broward County residents expressed they would actively commute rather than use a car if they had better connectivity and felt safe walking, bicycling, or wheeling throughout their community (Urban Health Partnerships, Inc., *Broward Complete Streets Initiative Community Engagement Report*, 2012).

Solutions that have the broadest impact may be found at the network scale rather than at individual street segments. The design of the network establishes the role of, and design parameters for, individual street or corridor designs.

The studies cited above and others provide strong evidence that the benefits of a well-designed street network go beyond safety; they include health, environmental, social, and economic gains. Sustainable street networks shape land use markets and support compact development, in turn decreasing the costs of travel and providing utilities. Street networks like these are resilient over hundreds of years and accommodate changing technology, lifestyles, and travel patterns. Interconnected street networks can preserve habitat and important ecological areas by condensing development, reducing city edges, and reducing sprawl.

## ESSENTIAL PRINCIPLES OF SUSTAINABLE STREET NETWORKS

Sustainable street networks come in many shapes and forms, but have the following overarching principles in common.

- The sustainable street network both shapes and responds to the natural and built environment.
- The sustainable street network privileges trips by foot, bike, and public transit because these are the most sustainable types of trips.
- The sustainable street network is built to walking dimensions.
- The sustainable street network works in harmony with various transportation systems, such as pedestrian, bicycle, transit, and private vehicle. Large parts of all of these networks are coincidental with the street network, but if any parts are separate from the street network, they must connect and interact with the network.
- The sustainable street network protects, respects, and enhances a city's natural features and ecological systems.
- The sustainable street network maximizes social and economic activity.
- The sustainable street network provides the option to age in place and affordably access daily activities and goods.



## APPROACH

Sustainable street networks should provide for the following outcomes.

- Sustainable street networks should provide a high level of connectivity so that motorists, pedestrians, bicyclists, and transit riders can choose the most direct routes and access urban destinations.
- Intersperse arterial thoroughfares with a system of intermediate collector thoroughfares serving local trips connecting neighborhood destinations.
- Build network capacity and redundancy through a dense, connected network of small streets rather than through an emphasis on super-wide arterial facilities with high capacity.
- Expand the typical definition of collectors to recognize their role in connecting local origins and destinations rather than just connecting local streets to arterial boulevards.
- Multimodal street network planning should be integrated into long-range transportation plans, comprehensive plans, and land use plans.

## CONNECTIVITY INDEX

A Connectivity Index can be used to quantify how well a street network connects destinations. Indices can be measured separately for motorized and non-motorized travel. Several methods can be used according to the Victoria Transport Policy Institute (VTPI) at [www.vtpi.org](http://www.vtpi.org).

- The number of roadway links divided by the number of roadway nodes or intersections (Ewing, 1996). A higher index means that travelers have increased route choice, allowing more direct connections for access between two locations.
- The ratio of intersections divided by the sum of intersections and deadends, expressed on a scale from zero to one (U.S. Environmental Protection Agency, 2002). The closer the index is to 1.0, the more connected the street network.
- The number of surface street intersections within a given geographic area, such as a square mile (intersection density). The more intersections, the greater the degree of connectivity.
- An Accessibility Index as the ratio of direct travel distances to actual travel distances. Well-connected streets result in a high index. Less connected streets with large blocks result in a lower index.
- The Walking Permeability Distance Index (WPDI) deals specifically with an accessibility index for walking trips. (Allan 2001; Soltani and Allan 2005). It aggregates walkability factors such as street connectivity, street width, and sidewalk quality.

## STREET CHARACTERISTICS AND CLASSIFICATIONS

A sustainable street network provides a pattern of multimodal streets that serves all community land uses and facilitates easy access to local, city, and regional destinations. The pattern, which should give priority to non-motorized modes, results in distribution of traffic



that is consistent with the desired function of the street. One characteristic of this pattern is that it offers many route choices that connect origins with their destinations.

The street network works best when it provides a variety of street types. The variety is enforced by the pattern of the street network itself but also by the design of individual street segments. Natural and built features, including topography and important community destinations, should be taken into account to create unique designs.

In new subdivisions, integrating a network of shared use paths and earthen trails into the street network should be considered. Under this concept, every fourth or fifth “street” provides quiet, comfortable access for bicyclists, pedestrians, joggers, skaters, wheel chair users, and others along a linear parkway without motor vehicles. Where these intersect streets, they should be treated as intersections with appropriate treatments. This type of network would allow people to circulate in their new communities to schools, parks, stores, and offices while staying primarily on dedicated paths and trails. These networks can also link to paths and trails along waterways, utility corridors, rail rights-of-way, and other more common active transportation corridors. The adjacent diagram illustrates this concept.



*Integrating bicycle and pedestrian paths into new development  
 (Credit: Michele Weisbart)*

The types of streets used in the network are described in the design standards below (see number 13). The types differ in terms of their network continuity, cross-section design, and adjoining land use. The individual streets themselves will change in character depending on their immediate land use context.



*Multi-family development in Coconut Creek with a shared-use path connecting to Tradewinds Park  
 (Credit: Kimley-Horn and Associates, Inc.)*



### CONTEXT: THE TRANSECT

Context is the environment in which the street is built and includes the placement and frontage of buildings, adjacent land uses and open space, and historic, cultural, and other characteristics that form the built and natural environments of a given place. The transect is a recognized tool for defining the context and assists designers in creating an appropriate design for the context. Andres Duany of Duany, Plater, Zyberk & Company developed the transect.

The transect zones range from T1 (Natural) to T6 (Urban Core). In the least-intensive T-Zones of a community, T1 and T2, a rural road or highway is appropriate.

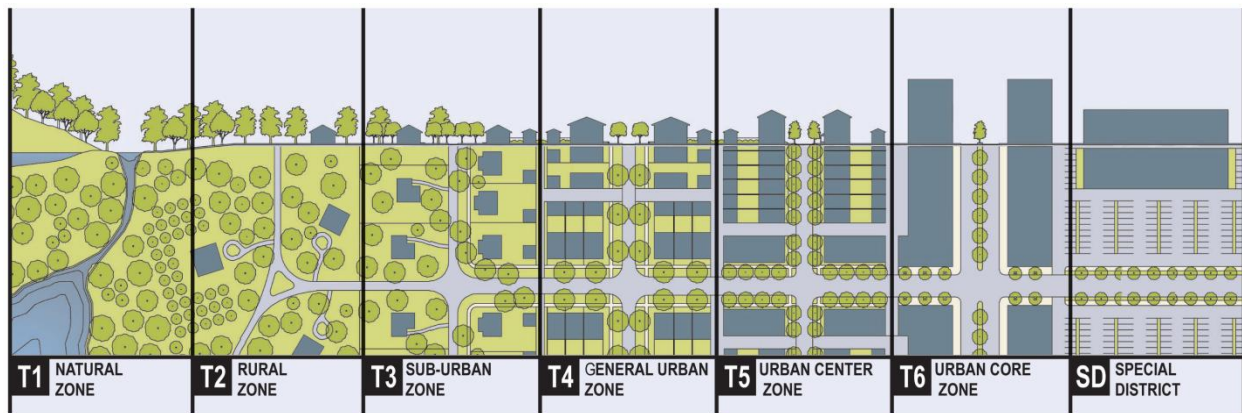

*The transect zones (Credit: Duany, Plater, Zyberk & Company)*

By definition, the urban T-Zones T3 through T6 do not exist as “stand alone” zones, but rather are organized in relationship to each other within a community. Each T-Zone is highly walkable and assumes the pedestrian mode as a viable and often preferred travel mode, especially for the ¼ mile, five-minute walk.

The T3 suburban zone defines the urban to rural edge. Of all the T-Zones, T3 appears most like conventional sprawl. It has single-family dwellings, a limited mix of uses and housing types, and tends to be more automobile-oriented than T4, T5, or T6. The five-minute test of walkable distance (¼ mile radius) limits the overall size of a T3 transect zone. The T3 zone often defines the edge of the more developed urban condition, so is sometimes called the “neighborhood edge.”

For example, knowing that a particular area is a T5, Town Center, defines the context for the built environment including the street design criteria and elements, such as the width of sidewalks, the presence of on-street parking, and the use of tree wells instead of planting strips. Buildings built to the sidewalk with parking on the street and behind, for instance, are appropriate in T5 and T6. Referring to a set of tables and design recommendations correlated to the transect helps the designer determine how a street should function in each T-Zone.



Contexts will not always flow evenly and incrementally from T1 to T6: there may be gaps. For example, T2 jumps to T5 may occur, or a rural community may have only T2 with a community center that is not urban enough to be T5 (for example, a church, convenience store, antique store, and gas station at the one intersection in the whole town).

An important element of the design process is to ensure the travelled way design fits the context of the intended design. Through use of a regulating plan, the appropriate street design will be established to fit the context, purpose, and type of street.

## DESIGN STANDARDS

1. Establish a block size maximum of 1,320 linear feet (perimeter).
  - Ensure greater accessibility within the block through alleys, service courts, and other access ways.
  - Where block size is exceeded, retrofit large blocks with new street, alleys, pedestrian and/or bicycle connections.
  - For existing street networks, do not allow street closures that would result in larger blocks.
2. The basic form of the street network system is shaped by the spacing and alignment of the major thoroughfares (continuous boulevards and avenues). Major continuous thoroughfares should be spaced as follows based on context zone.
  - Dense urban centers (T5 and T6)
    - Thoroughfares @ 1,320 feet
  - General urban centers (T4)
    - Thoroughfares @ 2,640 feet
  - Conventional suburban areas
    - Thoroughfares @ 5,280 feet
3. Require multiple street connections between neighborhoods and districts across the whole region. This is achieved by having boulevards and avenues that extend beyond the local area. Adjacent neighborhoods must also be connected by multiple local streets.
4. Connect streets across urban freeways so that pedestrians and bicyclists have links to neighborhoods without having to use streets with freeway on and off ramps.
5. Maintain network quality by accepting growth and the concomitant expansion of the street network (including development, revitalization, intensification, or redevelopment) while avoiding increases in street width or in number of lanes
6. Provide on-street curbside parking on most streets. Exceptions can be made for very narrow streets, streets with bus lanes, or where there is a better use of the space.



7. Establish maximum speeds of 20 to 35 mph.
  - Use design features that support lower-speed environments including tight corner radii, travel lanes of 10 to 11 feet in width, robust landscaping, roundabouts, and frequent marked pedestrian crosswalks.
  - On local streets, the speed should be 20 to 25 mph or less.
  
8. Maintain network function by discouraging the following poor connectivity features.
  - One-way streets
  - Turn prohibitions
  - Full or partial closures (except on bike boulevards, or areas taken over for other uses of public space)
  - Removal of on-street parking (except when replaced by wider sidewalks, an enhanced streetscape, bus lanes, bike lanes, etc. rather than additional vehicle lanes)
  - Gated streets
  - Widening of individual streets
  - Conversion of city streets to limited access facilities
  
9. Include a system of bicycle facilities with parallel routes no more than one-half mile apart.
  
10. Pedestrian facilities should be defined by block lengths and should be located on both sides of streets.



*Many more destinations can be reached walking 300' within a network of short blocks than in one with long blocks  
(Credit: Marty Bruinsma)*



11. Local streets should be configured in a fine-grained multimodal network internal to neighborhoods.
12. Pedestrian shortcuts should be provided in locations where the network is broken.
13. Classify major streets using the common street and context types presented in Table 4.1. However, some streets are unique and deserve a special category that lies outside the common street network types. Table 4.2 describes these special streets. Chapter 5, “Traveled Way Design,” contains guidance related to cross sections of these street typologies. New street types should be welcomed as well.

#### TYPES AND ROLES OF STREETS

The Federal Highway Administration (FHWA) Functional Classification Guidelines contain the conventional classification system that is commonly accepted to define the function and operational requirements for streets. These classifications are also used as the primary basis for geometric design criteria.

Traffic volume, trip characteristics, speed and level of service, and other factors in the functional classification system relate to the mobility of motor vehicles, not bicyclists or pedestrians, and do not consider the context or land use of the surrounding environment. This approach, while appropriate for high speed rural and some suburban roadways, does not provide designers with guidance on how to design for complete streets or in a context-sensitive manner.

While the conventional functional classification system characterizes roadways by vehicular functions, the street types presented in Tables 4.1 and 4.2, and described on the following pages, consider broader roles and functions of urban streets. The street types described here provide mobility for all modes of transportation with a greater focus on the pedestrian. The functional classification system can be generally applied to the street types in this document. Designers should recognize the need for greater flexibility in applying design criteria, based more heavily on context and the need to create a safe environment for pedestrians, rather than strictly following the conventional application of functional classification in determining geometric criteria.

The terms for street types for complete streets are described in the following sections. Many local governments in Broward County use the terms “avenue” and “street” in combination with the street name as a way to differentiate streets running north and south from those running east and west (e.g., 1st Street, 1st Avenue); these uses differ from the definitions used in this manual.



## Boulevard

A boulevard is a walkable, divided arterial street designed for high vehicular capacity and moderate speed, traversing an urbanized area. Boulevards serve as primary transit routes and should have bike lanes. Boulevards serve as primary goods movement and emergency response routes and typically use vehicular and pedestrian access management techniques. Boulevards may be equipped with bus lanes or side access lanes (multiway boulevards) buffering sidewalks and buildings. Many boulevards also have landscaped medians. Boulevards are similar to arterials in the conventional street functional classification system.



*Boulevard example: Hillsboro Boulevard  
(Credit: City of Deerfield Beach)*



*Boulevard example: Las Olas Boulevard  
(Credit: Luisa Fernanda Arbeláez)*



### Avenue

An avenue is a walkable street of moderate to high vehicular capacity and low to moderate speed acting as a short distance connector between urban centers and serving as access to abutting land. Avenues may be equipped with a landscaped median or a two-way left-turn lane median (common after road diet conversions). Avenues serve as primary pedestrian and bicycle routes and may serve local transit routes. Avenues may serve commercial sectors or a mix of commercial and residential uses. Avenues are similar to urban minor arterials or urban collectors in the conventional street classification system.



*Avenue example (Credit: City of Charlotte, NC)*



*Avenue example (Credit: Kimley-Horn and Associates, Inc.)*



## Street

A street is a local, walkable, multi-movement facility suitable for all urbanized transect zones and all frontages and uses. Speeds should be no higher than 25 mph. Commercial and mixed-use streets are urban in character, with raised curbs (except where curbless treatments such as festival streets are designed), small corner radii, wide sidewalks, parallel parking, and trees in individual or continuous planters. Residential streets typically have curbs in the T5 and T6 transects, but can be either curbed or curbless in other transects. The primary purpose is to serve abutting property and local traffic.



*Street example (commercial): Sanford, FL (Credit: Billy Hattaway)*

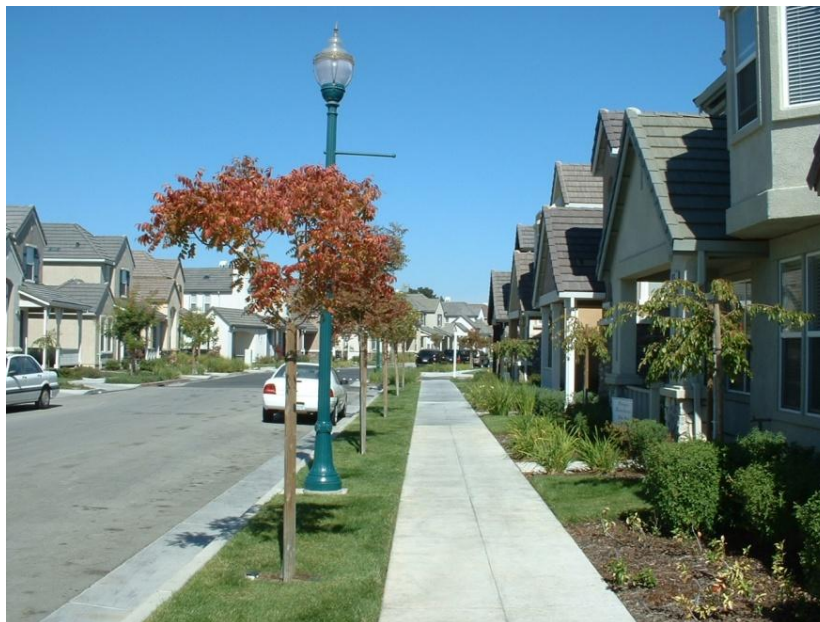

*Street example (residential) (Credit: Kimley-Horn and Associates, Inc.)*



### Alley/Lane

An alley or lane is a narrow street, often without sidewalks, where vehicles travel at walking speeds. Alleys and lanes connect streets and provide access to the back of buildings or garages.



*Alley example (residential): Chapel Hill, NC (Credit: Ryan Snyder)*



*Alley example (commercial): Boca Raton, FL (Credit: Kimley-Horn and Associates, Inc.)*



Table 4.1 provides a list of common street types. The special street typologies listed in Table 4.2 have particular functions within the street network. Photos of special street types follow Table 4.2.

**Table 4.1 Common Street Types**

Street Type	Description	Comment
Boulevard* (conventionally called arterials)	Walkable, moderate speed divided arterial in urban environments that traverses and connects districts and cities. Primarily a longer distance route for all vehicles including transit, goods movement, and emergency response. Design speeds should be 35 mph or less.	Serves as primary transit routes. Should have bike lanes and sidewalks standard. May have shared-use paths. Often has a planted median. May have on-street parking when passing through urban centers and urban cores.
Avenue* (conventionally called collectors or urban minor arterials)	Walkable, low speed collector or minor arterial that serves as a short-distance connector between districts or urban centers and provides access to abutting land. Links streets with boulevards. For all vehicles including transit. Design speeds should be 30 mph or less; strong consideration should be given for 25 mph or less when on-street parking is provided.	Serves as primary pedestrian and bicycle routes. Should have local transit routes. May or may not have a median. May or may not have on-street parking depending on context.
Street* (conventionally called local streets)	Walkable, low speed facility that primarily serves as access to abutting properties and local traffic in neighborhoods. Connects to adjoining neighborhoods. Serves local function for vehicles and transit. Design speeds should not exceed 25 mph.	Can be commercial or residential. Bicycles are served by shared space. Commercial streets should always have sidewalks. Residential streets should have sidewalks unless traffic volumes are less than 1,200 per day and speeds are 25 MPH or less.
Alley/Lane	Walkable link between streets; allows access to garages.	Narrow space characterized by walking speeds.
*May have segments with specialized functions and features such as a Main Street segment.		



**Table 4.2 Special Street Types**

Special Street Type	Description	Comment
Main Street	Slower vehicle speeds, favors pedestrians most, contains the highest level of streetscape features, typically dominated by retail and other commercial uses	Functions differently than other streets in that it is a destination
Drive	Located between an urbanized neighborhood and park or waterway	Can be a local street or an alley
Transit Mall	The traveled way is for exclusive use by buses or trains, typically dominated by retail and other commercial uses	Excellent pedestrian access to and along the transit mall is critical. Bicycle access may be supported.
Bike Boulevard	A continuous through street for bicycles, but short distance travel (local access) for motor vehicles	Usually a local street with low traffic volumes and low speeds
Festival Street	Contains traffic calming, flush curbs, sidewalks separated by bollards, and streetscape features that allow for easy conversion to public uses such as farmers' markets and music events	Often a commercial street in a downtown context that has the special design features listed to the left
Shared Space	Slow, curbless street where pedestrians, motor vehicles, and bicyclists share space	May support café seating, play areas, and other uses

### ADDITIONAL RESOURCES

Institute of Transportation Engineers. *Designing Walkable Urban Thoroughfares: A Context Sensitive Approach*, 2010.

Institute of Transportation Engineers. *Planning Urban Roadway Systems: An ITE Proposed Recommended Practice*, 2011.

Zhou, N. and Smith, P. "Estimated VMT and GHG Emission Reductions Associated with the Going to the River Project," *Institute of Transportation Engineers (ITE) Journal*, 2012, 82[5]: 42-47.



*Main Street example with street café  
(Credit: Kimley-Horn and Associates, Inc.)*



*Drive example near Victoria Park  
(Credit: Kimley-Horn and Associates, Inc.)*



*16<sup>th</sup> Street Transit Mall: Denver, CO  
(Credit: Ryan Snyder)*



*Bicycle boulevard with bike box intersection  
(Credit: Toole Design Group)*



*Festival street with flush sidewalks separated by bollards  
(Credit: Kimley-Horn and Associates, Inc.)*



*Shared space: Copenhagen, Denmark  
(Credit: Ryan Snyder)*



## 5. TRAVELED WAY DESIGN

INTRODUCTION.....	1
ESSENTIAL PRINCIPLES OF TRAVELED WAY DESIGN .....	2
FACTORS AFFECTING STREET DESIGN.....	3
Users.....	3
Traffic Volume and Composition .....	6
Design Speed.....	7
Multi-Modal Level of Service .....	8
Access Management .....	10
CROSS SECTIONAL ELEMENTS .....	13
Context .....	13
On-Street Parking.....	13
Bicycle Facilities.....	15
Transit Facilities.....	15
Travel Lanes .....	15
Medians .....	18
Sample Cross Sections .....	19
OTHER GEOMETRIC DESIGN ELEMENTS.....	27
Vertical Alignment.....	27
Horizontal Alignment .....	27
Transition Design.....	27
Sight Distance.....	27
Horizontal Clearance/Clear Zone .....	28
Traveled Way Lighting .....	28
MODEL PROJECT .....	29
La Jolla .....	29
ADDITIONAL RESOURCES .....	29



*(Credit: Kimley-Horn and Associates, Inc.)*



## INTRODUCTION

Streets and their geometric design have traditionally focused on the movement of motor vehicles, resulting in street environments that neglect other users. This emphasis can be seen in wide travel lanes, large corner radii, and turn lanes that severely impede the safety of pedestrians and the overall connectivity for non-automobile users. The geometric design of the traveled way and intersections has usually reflected the need to move traffic as quickly as possible. A paradigm shift needs to occur to reclaim the public right-of-way for pedestrians and bicyclists and create complete streets.



*Wide, uninviting boulevard; a typical existing condition  
 (Credit: Kimley-Horn and Associates, Inc.)*

Traveled way design in this chapter is defined as the part of the street right-of-way between the two faces of the outside curbs and can include bicycle lanes, parking lanes, transit lanes, general use travel lanes, and medians. The traveled way contains the design elements that allow for the movement of vehicles, including bicycles, transit, automobiles, and trucks. The design of the traveled way is critical to the design of the entire street right-of-way because it

***“I (am) scared when I walk because cars (are) speeding and police catch them. I (am) scared to ride my bike because of cars.”***

*- Participant in Broward Complete Streets focus group with elementary students)*

typically utilizes the largest portion of the right-of-way and it affects not just the users in the traveled way, but those using the entire right-of-way, including the areas adjacent to the street. As a note on terminology, “traveled way” in this document is more or less the equivalent of “roadway” in most conventional design manuals: the curb-to-curb portion of a curbed street. The Manual on Uniform Traffic Control Devices (MUTCD) defines roadway as that portion of a highway improved, designed, or ordinarily used for vehicular travel and parking lanes, but exclusive of the sidewalk, berm, or shoulder.



## ESSENTIAL PRINCIPLES OF TRAVELED WAY DESIGN

The following key principles should be kept in mind for a well-designed traveled way.

- **Design to accommodate all users.** Street design should accommodate *all* users of the street, including pedestrians crossing the street, bicyclists, transit users, automobiles, and commercial vehicles. A well-designed traveled way provides appropriate space for all street users to coexist.
- **Design using the appropriate speed for the surrounding context.** The right design speed should respect the desired role and responsibility of the street, including the type and intensity of land use, urban form, the desired activities on the sidewalk, such as outdoor dining, and the overall safety and comfort of pedestrians and bicyclists. The speed of vehicles impacts all users of the street and the livability of the surrounding area. Lower speeds reduce crashes and injuries. When a roadway is being reconstructed or resurfaced, designers should select a design speed that respects these factors and should not simply default to the previous design speed of the roadway.
- **Design for safety.** The safety of all street users, especially the most vulnerable users (children, the elderly, and disabled) and modes (pedestrians and bicyclists) should be paramount in any design of the traveled way. The safety of streets can be dramatically improved through appropriate geometric design and operations.



*Design to accommodate all users.  
Everyone from schoolchildren to the elderly should feel safe  
using our streets.  
(Credit: Broward MPO)*

Building on the momentum of complete streets that have been successfully implemented in different parts of the nation and around the world, there is a strong need for Broward County to retrofit existing streets and create new types of street environments that reflect the values and desires of all users. This chapter discusses different factors affecting traveled way design. Individual geometric design elements such as lane width and sight distance are examined in greater detail. The benefits and constraints of each element are examined and the appropriate location and correct use of each element is defined to maximize the creation of complete streets. Finally, a case study of La Jolla Boulevard in San Diego demonstrates the benefits of well-designed traveled ways.



## FACTORS AFFECTING STREET DESIGN

### USERS

#### Pedestrians

Walking is the most basic mode of transportation, yet pedestrian mobility is often significantly restricted in roadway design. These restrictions to pedestrian mobility are often based on a misplaced attempt at safety and a general unwillingness to sacrifice any amount of motor vehicle speed or level of service. Certain areas generate high pedestrian activity, such as downtowns, residential, commercial, and entertainment areas, and schools. Yet even in areas of low pedestrian activity, such as along commercial strip-developed arterials, pedestrian needs and safety must be addressed, as drivers usually don't expect pedestrians, who are more vulnerable if a crash occurs. Much of this is due to speed. As speeds increase, drivers are less attentive to what is happening on the side of the road, reaction time is increased, and the pedestrian has a higher chance of dying or becoming severely injured in case of a crash.

Most pedestrian crashes occur when a person crosses the road, and the most common crash type is a conflict between a crossing pedestrian and a turning vehicle at an intersection.

But designing for pedestrians should not focus primarily on avoiding crashes; the goal of roadway and intersection design should be to create an environment that is conducive to walking, where people can walk along and cross the road, where the roadside becomes a place where people want to be. The two most effective methods to achieve these goals are to minimize the footprint dedicated to motor vehicle traffic and to slow down the speed of moving traffic. This approach allows the designer to use many features that enhance the walking environment, such as trees, curb extensions, and street furniture, which in turn slow traffic: a virtuous cycle. All streets should have sidewalks except for rural roads and shared-space streets.



*Pedestrian crossing a super-wide boulevard with very long block spacing  
(Credit: Kimley-Horn and Associates, Inc.)*



See Chapter 7, “Universal Pedestrian Access,” for specifics of sidewalk design and Chapter 8, “Pedestrian Crossings,” for specifics of pedestrian crossings.

### Bicyclists

All streets should be designed with the expectation that bicyclists will use them. This expectation is consistent with *Florida State Statute 316* and the Florida Department of Transportation (FDOT) Plans Preparation Manual (PPM). This does not mean every street needs a dedicated bicycle facility, nor will every road accommodate all types of bicyclists. Minimizing the footprint dedicated to motor vehicle traffic and slowing down the speed of moving traffic benefits bicyclists. Chapter 9, “Bikeway Design,” describes in greater detail the various types of bikeways and their application. Ideally, all multi-lane streets should have bike lanes. On multi-lane streets where bike lanes aren’t feasible because of space constraints, other bikeway treatments should be applied.



*Bicyclist in Commercial Boulevard bike lane  
(Credit: Kimley-Horn and Associates, Inc.)*

### Public Transportation

Designing for transit vehicles on roadways takes into consideration many factors. Buses have operational characteristics that resemble trucks - they usually operate in mixed traffic, they stop and start often for passengers, and they must be accessible to people boarding the bus. The consequences for roadway design include lane width (in most cases buses can operate safely in travel lanes designed for passenger cars), intersection design (turning radius or width of channelization lane),



*Broward County Transit bus  
(Credit: Kimley-Horn and Associates, Inc.)*



signal timing (on several Broward corridors, signal timing is adjusted to give transit an advantage), pedestrian access (crossing the street at bus stops), sidewalk design (making room for bus shelters in the furniture zone), and bus stop placement and design (farside/nearside at intersections, bus pullouts, or bulb outs).

Chapter 10, “Transit Accommodations,” describes in greater detail these and other design and operational considerations. Where express bus service or Bus Rapid Transit is provided, exclusive bus lanes are desirable. These have unique operating characteristics that are beyond the scope of this manual.

### Emergency Vehicles

Major urban arterial boulevards and avenues are the primary conduits for emergency response vehicles including police, fire, and ambulance. Emergency vehicle access and operations should always be considered in traveled way design. Many factors affect emergency vehicle response time including congestion, width of street and travel lanes, geometric design of intersections, access management features, signal timing, and the presence of signal pre-emption devices.

The following principles should be considered in designing traveled ways to accommodate emergency vehicles.

- High levels of street connectivity improve emergency response time by providing alternate routes. Look for opportunities to improve overall network connectivity.
- When establishing new or reviewing existing access management configurations, care should be taken to permit direct routing capability to emergency vehicles.
- On streets with medians, traffic circles, tight corner radii, or other access management features, emergency response time may be reduced by the implementation of mountable curbs to allow emergency vehicles to cross.

### Design Vehicles

The design vehicle influences several geometric design features including lane width, corner radii, median nose design, and other intersection design details. Designing for a larger vehicle than necessary is undesirable, due to the potential negative impacts larger dimensions may have on pedestrian crossing distances and the speed of turning vehicles. On the other hand, designing for a vehicle that is too small can result in operational problems if larger vehicles frequently use the facility.

For design purposes, the WB-40 (wheel-base 40 feet) is appropriate unless larger vehicles are more common. On bus routes and truck routes, designing for the bus (CITY-BUS or similar) or large truck (either the WB-50 or WB-62FL design vehicle) may be appropriate, but only at intersections where these vehicles make turns. For example, for intersection geometry design features such as corner radii, different design vehicles should be used for each intersection or even each corner, rather than a “one-size-fits-all” approach, which results in larger radii than needed at most corners. The design vehicle should be accommodated without encroachment



into opposing traffic lanes. It is generally acceptable to have encroachment onto multiple same-direction traffic lanes on the receiving roadway.

Furthermore, it may be inappropriate to design a facility by using a larger “control vehicle,” which uses the street infrequently, or infrequently makes turns at a specific location. An example of a control vehicle is a vehicle that makes no more than one delivery per day at a business. Depending on the frequency, by under designing the control vehicle can be allowed to encroach on opposing traffic lanes or make multiple-point turns.

#### TRAFFIC VOLUME AND COMPOSITION

Traffic volume data collection is an integral part of transportation planning and decision making. Traffic volume data are collected for various periods of the day depending on the purpose for which the data is used. For most analyses it is necessary to collect peak period and daily traffic. Peak period traffic could be further divided into morning (a.m.), mid-day (m.d.), and evening (p.m.) peak periods. Daily traffic data is also called average daily traffic (ADT). Other types of data collected are annual daily traffic, average annual daily traffic, average weekday traffic, hourly traffic (usually at intersections), and short-term counts as required. There are special types of traffic volume counts such as vehicle classification counts and average vehicle occupancy. The traffic volumes collected are also used for a variety of studies, including forecasting. Traffic volume on a segment of a road or at an intersection can be collected either manually or by using tubes.

The ADT volume is the most commonly collected traffic volume data. The ADT provides both the peak period traffic and the total daily traffic for analysis purposes. Typical ADT data for a central business district (CBD) will show an a.m., mid-day, and p.m. peak volume, which clearly indicates the typical usage of the CBD.

Vehicle classification counts are conducted on a daily basis to determine the types of vehicles using the roadway. The vehicle classification devices currently in use accurately record axle impulses, but do not provide consistent and accurate interpretation of axle impulses into classification of vehicles when vehicles (typically in urban areas) are traveling at speeds below 25 mph. The Federal Highway Administration (FHWA) has classified trucks into several categories based on the number of axles.

Turning movement volumes are collected at intersections to record the various turning movements. The collection of data on turning movements allows determining the level of service and making improvements to the intersection to reduce delay and idling for all vehicles. The data collected on traffic volumes and turning movements helps to determine the number of travel lanes needed.



## DESIGN SPEED

The application of design speed for complete streets is philosophically different than for conventional transportation practices. Traditionally, the approach for setting design speed is to use as high a design speed as practical. The intent of this approach when it was developed was to move people and goods in automobiles as efficiently as possible over long distances. In addition, it was thought that achieving similar speeds for all motor vehicles using a roadway would maximize safety by minimizing speed differentials. However, this approach has many negative effects. Speed kills places as well as people, and inherently places efficiency over access even though access is just as fundamental. Because high design speeds reduce access to places on foot, they degrade the social and retail life of a street and devalue the adjacent land. Local economies thrive on attracting people.

In contrast to this approach, the goal for complete streets is to establish a design speed that creates a safer and more comfortable environment for motorists, pedestrians, and bicyclists. This approach also increases access to adjacent land, thereby increasing its value, and therefore is appropriate for the surrounding context. For complete streets, design speeds of 20 to 35 mph are desirable. Alleys and narrow roadways intended to function as shared spaces may have design speeds as low as 10 mph. Design speed does not determine nor predict exactly at what speed motorists will travel on a roadway segment; rather, design speed determines which design features are allowable (or mandated). Features associated with high-speed designs, such as large curb radii, straight and wide travel lanes, ample clear zones (no on-street parking or street trees), guardrails, etc., degrade the walking experience and make it difficult to design complete streets. In the end, the design of the road encourages high speeds and creates a vicious cycle. A slower design speed allows the use of features that enhance the walking environment, such as small curb radii, narrower sections, trees, on-street parking, curb extensions, and street furniture, which in turn slow traffic: a virtuous cycle.

### Movement Types

The following movement types are used to describe the expected driver experience on a given street and the design speed for pedestrian safety and mobility established for each of these movement types. They are also used to establish the components and criteria for design of complete streets.

- **Yield:** Drivers must proceed slowly and with extreme care and must yield in order to pass a parked car or approaching vehicle. This is the functional equivalent of traffic calming. With a design speed of less than 20 mph, this type should accommodate bicycling through the use of shared lanes.
- **Slow:** Drivers can proceed carefully with an occasional stop to allow a pedestrian to cross or another car to park. Drivers should feel uncomfortable exceeding design speed due to the presence of parked cars, a feeling of enclosure, tight turn radii, and other



design elements. With a design speed of 20 to 25 mph, this type should accommodate bicycling through the use of shared lanes.

- **Low:** Drivers can expect to travel generally without delay at the design speed; street design supports safe pedestrian movement at the higher design speed. This movement type is appropriate for streets designed to traverse longer distances or that connect to higher intensity locations. With a design speed of 30 to 35 mph, this type can accommodate bicycling with the use of designated bike lanes.

Design speeds higher than 35 mph should not normally be used within communities, or in Transects T3 and above. Speeds greater than 30 mph or 35 mph violate the principles of complete streets. Realizing actual average network travel speeds greater than 35 mph is very uncommon in urban environments due to traffic signal spacing and timing. Lowering the design speed to no more than 35 mph within Transects T3 through T6 would help reduce the “hurry up and wait” condition that often prevails in the urban driving experience.

Communities that have streets functioning at speeds greater than 35 mph may want to adopt a goal to redesign the corridor to reduce the speed to 35 mph or less, especially during reconstruction or resurfacing projects. The increase in motorist travel time due to the speed reduction is usually insignificant because communities designed with complete streets are generally compact. When the speed reduction cannot be achieved, measures to improve pedestrian safety for those crossing the corridor should be evaluated and installed where appropriate.



*High automobile level of service, but poor multi-modal level of service  
(Credit: Kimley-Horn and Associates, Inc.)*

#### MULTI-MODAL LEVEL OF SERVICE

Municipalities use qualitative assessments to describe the perceived service a street provides to the people using the facility. The quality of service has conventionally been obtained using Level of Service (LOS) measurements. LOS assesses delay for motorists along a roadway section or at a signalized intersection. The LOS is defined using letters A to F, where LOS F denotes the greatest delay and LOS A no delay. The LOS is used to develop solutions to improve the existing

system to achieve the desired LOS. This convention considers quality of service for only automobiles and other vehicles (commercial) using the roadway system. The *Highway Capacity Manual* (HCM) provides details of the LOS computations for roadways and intersections.

Since traveled ways are used by different modes, the multimodal level of service (MMLOS) was developed under National Cooperative Highway Research Program (NCHRP) Project 3-70. The MMLOS was developed for urban streets and it is currently designed for analysis of steady state conditions during a specified analysis period. MMLOS applies to urban streets with all modes of travel (cars, pedestrians, transit, and bicycles) and assesses the impacts of facility design and operation on all users except for commercial vehicles. The MMLOS analysis provides a tool to predict travel perceptions of quality of service.



*High multi-modal level of service  
 (Credit: Ryan Snyder)*

The MMLOS for the four modal usages is output as numerical ratings, which are converted into the traditional A to F letter grade system. Table 5.1 indicates the MMLOS letter grade equivalents of the numerical values obtained.

**Table 5.1 MMLOS Letter Grade Equivalents**

MMLOS Modal Output	MMLOS Letter Grade
Model ≤ 2.0	A
2.0 < Model ≤ 2.75	B
2.75 < Model ≤ 3.50	C
3.50 < Model ≤ 4.25	D
4.25 < Model ≤ 5.00	E
Model > 5.0	F

Source: NCHRP-Web Only Document 128: *Multimodal level of service analysis for urban streets: User Guide*, 2009.

Notes:

1. If any directional segment hourly volume/capacity ratio (v/c) exceeds 1.0 for any mode, that direction of street is considered to be operating at LOS F for that mode of travel for its entire length (regardless of the computed LOS).
2. If the movement of any mode is legally prohibited for a given direction of travel on the street, then the LOS for that mode is LOS "F" for that direction.



For conducting MMLOS it is necessary to select a roadway segment that has signalized intersections, transit usage, bicycle riders, and pedestrians. The segment could have 5 to 6 signals in the selected section. The data required for conducting MMLOS includes street geometrics, such as number of through lanes, width of lanes, median width, bike lane, shoulder width, parking lane width, sidewalk width, right turn lanes, transit stops, and signalized and un-signalized intersections. The methodology provides some basic default values for use, which can be found in the reference provided at the end of this chapter.

By conducting an MMLOS analysis of existing roadway segments, the agency will be able to identify the deficiencies in the system for all the modes. Using the results to change the analyzed street segment will improve the system for all users. The result should lead to very different decisions than would be made under the traditional LOS assessment. Using traditional LOS as the measurement, municipalities typically remedy low LOS by widening streets, flaring intersections, and other measures designed to improve the flow of motor vehicles only. In contrast, applying MMLOS can lead to improvements for pedestrians, bicyclists, and transit users. Since the development of the MMLOS, several other tools have been developed to capture other modes. Local jurisdictions are encouraged to research the most appropriate analysis method for their community prior to investing in one particular tool.

## ACCESS MANAGEMENT

Access management refers to properly locating and designing access to adjacent land use (context) to preserve safety and reasonable traffic flow. A major challenge in street design is balancing the number of access points to a street. As discussed in Chapter 4, “Street Networks and Classifications,” there are many benefits of well-connected street networks. On the other hand, most conflicts between users occur at intersections and driveways. The presence of many driveways in addition to the necessary intersections creates many conflicts between vehicles entering or leaving a street and bicyclists and pedestrians riding or walking along the street. When possible, new driveways should be minimized and old driveways should be eliminated or consolidated, and raised medians should be placed to limit left turns into and out of driveways.



Before

After

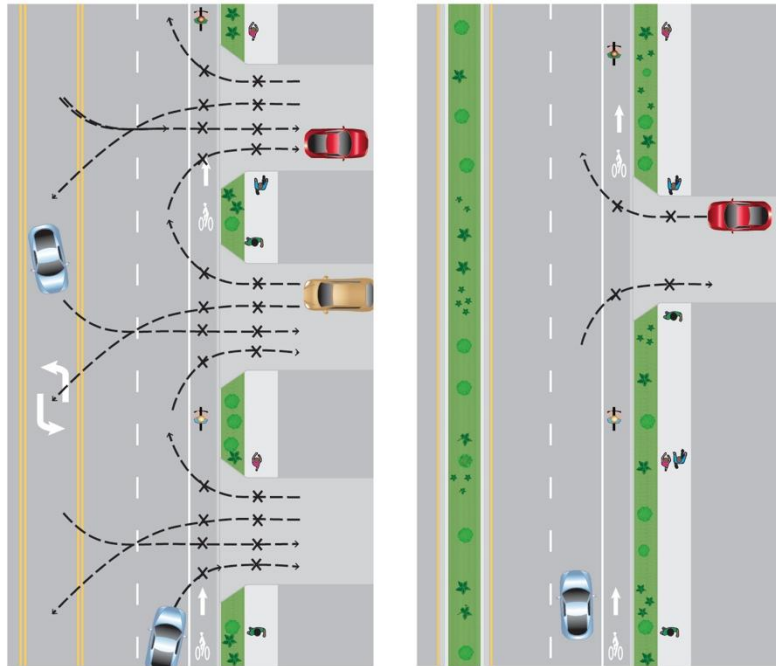

Adding medians and consolidating driveways to manage access  
(Credit: Michele Weisbart)

Access management requirements often include public street intersection spacing, especially signalized intersection spacing. FDOT’s access management guidelines generally restrict signalized intersection spacing to one every one-quarter mile (1,320 feet) on major thoroughfares. In dense urban centers (Transects T5 through T6), continuous thoroughfares (boulevards or avenues) should be spaced every one-quarter mile (1,320 feet), which is consistent with the FDOT policy. However, a grid network of streets should intersect the major thoroughfare between signalized intersections to provide access and locations for crossings.



Corner with many wide driveways  
(Credit: Michele Weisbart)



Reconstructed corner with fewer, narrower driveways  
(Credit: Michele Weisbart)



It has been demonstrated that good access management principles can reduce crashes by 50 percent or more, depending on the condition and the treatment used (*Access Management Manual*, Transportation Research Board, 2002). The following principles define good access management practices.

- Classify the street system by both function and context.
- Establish standards for intersection spacing. In urban areas, these standards should include both minimum spacing and maximum spacing. Access management studies should determine not only if minimum spacing standards are being violated, but also if maximum spacing standards are being violated (a.k.a. not enough connectivity within the network).
- Locate driveways away from intersections to minimize crashes and to minimize interference with traffic operations.
- Use curbed medians on boulevards (major thoroughfares) and locate median openings to manage access and minimize conflicts.
- Consolidate driveways in urban areas to reduce conflicts between vehicles, pedestrians, and bicyclists.

Access management through limiting driveways and providing raised medians has many benefits:

- The number of conflict points is reduced, especially by replacing center-turn lanes with raised medians since left turns by motorists account for a high number of crashes with bicyclists and pedestrians.
- Pedestrian crossing opportunities are enhanced with a raised median.
- Universal access for pedestrians is easier, since the sidewalk is less frequently interrupted by driveway slopes.
- Fewer driveways result in more space available for higher and better uses.
- Improved traffic flow may reduce the need for road widening, allowing part of the right-of-way to be recaptured for other users.

#### Possible Negatives of Access Management

The following possible negative effects of access management should be considered and addressed.

- Streamlining a street may increase motor vehicle speeds and volumes, which can be detrimental to other users.
- Reduced access to businesses may require out-of-direction travel for all users, including walkers and bicyclists.
- Concrete barriers and overly-landscaped medians act as barriers to pedestrian crossings. Medians should be designed with no more than normal curb height and with landscaping that allows pedestrians to see to the other side.



- Adjacent land uses can experience decreased access. This can impact businesses as well as residents. Careful planning of access management considers this.
- An overly protective approach to intersection spacing can lead to negative effects on network connectivity.

## CROSS SECTIONAL ELEMENTS

Complete street design treats streets as part of the public realm. The street portion of the public realm is shaped by the features and cross section elements used in creating the street. Attention to what features are included, where they are placed, and how the cross section elements are assembled is necessary.

### CONTEXT

The first design consideration that should be addressed when determining the optimum cross section for a traveled way is context. Determine the context zone and identify thoroughfare type based on the transect and classifications presented in Chapter 4, “Street Networks and Classifications.” Identifying the context first establishes the general parameters for the cross section.

### ON-STREET PARKING

On-street parking can be important in the urban environment (1) for the success of the retail businesses that line the street, (2) to provide a buffer for pedestrians, and (3) to help calm traffic speeds. On-street parking is efficient from a land use perspective because it occupies about half the surface area per car compared to off-street parking, which requires driveways and aisles for access and maneuvering. However, on-street parking cannot meet all of the parking demand in modern urban areas. Local jurisdictions should manage demand for on-street parking by charging market-rate prices. Free or underpriced parking encourages people to drive instead of taking transit, biking, or walking. Parking expert Donald Shoup recommends setting variable parking prices to target a 15 percent vacancy rate for curb parking. In addition to encouraging people to curtail driving, it also creates turnover that benefits retailers by making convenient parking available for short shopping trips.

General principles and considerations regarding on-street parking are presented below.

- On-street parking should be located based on the context of the urban roadway and the needs of the adjacent land use.
- On-street parking should be primarily parallel parking on urban arterial boulevards and avenues. Angle parking may be used on low-speed and low-volume commercially-oriented avenues and streets, primarily those serving as main streets.
- Orientation of parking should be determined based on design speed and ability of the right-of-way width to accommodate the desired elements.



- Where angle parking is proposed for on-street parking, designers should consider the use of reverse-in angle (or front out) parking in lieu of front-in angled parking. Motorists pulling out of reverse-in angled parking can better see the active street they are entering. This is especially important to bicyclists. Moreover, people exiting cars do so on the curb side and aren't likely to step into an active travel lane. However, reverse-in angle parking requires a wider edge zone to accommodate greater over-tracking of the rear of the vehicles.
- Use metered parking to enforce parking time limits that provide reasonable short-term parking for retail customers and visitors while discouraging long-term parking. Automated meter machines should be used for efficiency of parking management and to reduce street clutter and sidewalk obstacles.



*Reverse-in angled parking: Boise, ID  
(Credit: Dan Burden)*

Another tool for on-street parking is the park assist lane. Often when on-street parking is provided on busy roads, drivers find it difficult to enter and leave their parked vehicle. Where space is available, consideration should be given to adding a park assist lane between the parking lane and travel way to provide 3 feet of space so car doors can be opened and vehicles can enter or depart with a higher degree of safety and less delay. Bike lanes can serve this function as well. Parking assist lanes also narrow the feel of the travel lane and slow traffic.



*Parking assist lane  
(Credit: Michael Wallwork)*

Curbside extensions should be provided in place of on-street parking at mid-block crosswalks and intersection crosswalks. Curbside extensions reduce the distance that pedestrians must cross within the traveled way, help to calm traffic, and serve as opportunities for rain gardens and other forms of aesthetic enhancement.

On-street parking should be prohibited within 20 feet of either side of fire hydrants, at least 20 feet from mid-block



*Curbside extensions with rain garden  
(Credit: Unknown)*



crosswalks, and at least 30 feet from the corner radius of intersections (or greater if required to meet engineering sight distance requirements).

Table 5.2 below details recommended parking lane widths for slow and low movement types.

**Table 5.2 Parking Lane Widths**

Movement Type	Design Speed	Parking Lane Width
Slow, Avenues and Streets (residential)	20-25 mph	Angle: 16.5'(60°); 15'(45°) Parallel: 7 feet
Slow, Avenues and Streets (commercial)	20-25 mph	Angle: 19.0'(60°); 17.7'(45°) Parallel: 8 feet
Low, Boulevard	30-35 mph	Parallel: 8 feet

#### BICYCLE FACILITIES

Bicycle facilities within the traveled way may include conventional bicycle lanes, buffered bicycle lanes, contra-flow bicycle lanes on one-way streets, bicycle boulevards, other types of shared roadways (with or without shared lane markings), and cycle tracks. See Chapter 9, “Bikeway Design,” for design recommendations for these facilities.

#### TRANSIT FACILITIES

Transit accommodations within the traveled way may include dedicated transit lanes, bus bulbs, bus pullouts, and other features. See Chapter 10, “Transit Accommodations,” for design recommendations for these features.

#### TRAVEL LANES

Travel lane widths should be provided based on the context and desired speed for the area that the street is located in. Table 5.3 shows lane widths and the associated speeds that are appropriate. In low speed urban environments, lane widths are typically measured to the curb face instead of the edge of the gutter pan. Consequently, when curb sections with gutter pans are used, the vehicle, bike, and parking lane all include the width of the gutter pan.

General principles and considerations in the selection of lane widths include the following.

- In order for drivers to understand how fast they should drive, lane widths have to create some level of driver discomfort when driving too fast. The presence of on-street parking is important in achieving the speeds shown in Table 5.3. When designated bike lanes or



multi-lane configurations are used, there is more room for large vehicles, such as buses, to operate in, but car drivers will feel more comfortable driving faster than is desired.



Wide two-lane street (Credit: Ryan Snyder)



Narrow two-lane street (Credit: Michael Ronkin)

- Reducing travel lane width is one strategy of accommodating complete streets elements into the traveled way design, as required in the FDOT PPM, Volume I, Chapters 2 and 8.
- Where adjacent lanes in the same direction of travel are unequal in width, the outside lane should be the wider lane to accommodate bicyclists (only where bicycle lanes are not practical).
- Yield streets are typically residential two-way streets with parking on one or both sides. When the street is parked on both sides, the remaining space between parked vehicles (12 feet minimum) is adequate for one vehicle to pass through. Minimum width for a yield street with parking on both sides should be 26 feet curb face to curb face. Minimum width for a yield street with parking on one side should be 20 feet curb face to curb face.

**Table 5.3 Travel Lane Widths and Associated Design Speeds**

Movement Type	Design Speed	Travel Lane Width
Yield (shared space)	Less than 20 mph	12 feet
Slow, Avenue and Street (residential)	20-25 mph	9*-10 feet
Slow, Avenue and Street (commercial)	20-25 mph	10 feet
Low, Boulevard	30-35 mph	10-11** feet
Low, Boulevard Wide curb lane bicycle facility	30-35 mph	14 feet

- \*9 feet requires a design exception, but could be considered in low volume settings where lane width narrowing would provide desired complete streets elements.
- \*\*Generally, 10-foot lanes are preferred. On bus routes or where truck traffic exceeds 10 percent, 11-foot lanes should be considered for the outside motor vehicle travel lane only.



Alleys can be designed as one-way or two-way. Right-of-way width should be a minimum of 20 feet with no permanent structures located within the right-of-way that would interfere with vehicle access to garages or parking spaces, access for trash collection, and other operational needs. Pavement width should be a minimum of 12 feet. Coordination with local municipalities on operational requirements is essential to ensure that trash collection and fire protection services can be completed.

The lane widths presented in Table 4.3 are consistent with guidance provided by the American Association of State Highway and Transportation Officials (AASHTO), with the exception of the 9-foot lane consideration for slow speed avenues and streets in residential areas. In addition, the lane widths are consistent with FDOT's Transportation Design for Livable Communities (TDLC) in the PPM, Volume I, Chapter 21, also with the exception of the 9-foot lane consideration for slow speed avenues and streets in residential areas. It should be noted that it would be very unlikely that such a street would be an FDOT roadway. In addition, FDOT currently requires a minimum 11 feet for new construction or reconstruction; 10 feet is allowable for lane width narrowing on existing roadways when the purpose is to provide a designated bicycle facility.

### Turn Lanes

The need for turn lanes for vehicle mobility should be balanced with the need to manage vehicle speeds, the need to provide continuous bicycle lanes, and the potential impact on the border width such as sidewalk width. Turn lanes tend to allow higher speeds to occur through intersections, since turning vehicles can move over to the turn lane, allowing the through vehicles to maintain their speed.

Left-turn lanes are considered to be acceptable in an urban environment. This is because without them there are negative impacts to roadway capacity, as cars turning left from a straight lane often block the through movement of other vehicles. Sometimes just a left-turn pocket is sufficient, just long enough for one or two cars to wait out of traffic. The installation of a left-turn lane can be beneficial when used to perform a road diet such as reducing a four lane section to three lanes with the center lane providing for turning movements.

In urban transects (T4, T5, and T6), normally no more than one left-turn lane should be provided. Dual and triple left-turn lanes are typically the result of poor street connectivity within the network. While right turns from through lanes may delay through movements, they also create a reduction in speed due to the slowing of turning vehicles. The installation of right-turn lanes increases the crossing distance for pedestrians and the speed of vehicles; therefore, exclusive right turn lanes should rarely be used except at "T" intersections. When used, they should be mitigated with raised channelization islands. See Chapter 6, "Intersection Design," for more details.

The desired turn lane width is 9 to 10 feet for right-turn lanes and 10 to 11 feet for left-turn lanes.



## MEDIANS



*Well-designed street medians bring multiple benefits  
(Credit: Dan Burden)*

Medians are the center portion of a street that separates opposing directions of travel. Medians used on urban streets provide access management by limiting left turn movements into and out of abutting development to select locations where a separate left turn lane or pocket can be provided. The reduced number of conflicts and conflict points decreases vehicle crashes, provides pedestrians with a refuge as they cross the road, and provides space for landscaping, lighting, and utilities. These medians are usually raised and curbed. Landscaped

medians enhance the street or help to create a gateway entrance into a community.

Medians can be used to create tree canopies over travel lanes, contributing to a sense of enclosure. As shown in Table 5.4, medians vary in width. Recommended widths depend on available right-of-way and function. Because medians require a wider right-of-way, the designer must weigh the benefits of a median with the issues of pedestrian crossing: distance, speed, context, and available roadside width.

In urban areas, it may be desirable to plant trees in raised curbed medians for aesthetic purposes. Small caliper trees can be healthy in medians that are at least 6 feet wide, as long as a critical root area is provided. Larger trees are only possible when the median is at least 10 feet wide. Consult an urban forester for guidance on health requirements for trees in medians. Crash mitigation strategies on trees within the public right-of-way can be found in *A Guide for Addressing Collisions with Trees in Hazardous Locations*, Transportation Research Board, 2003.

Avoid providing overly wide medians in urban contexts (T4, T5, and T6) at the expense of bicycle lanes or unreasonable reductions in roadside widths for elements such as sidewalks.

**Table 5.4 Median Types and Widths**

Median Type	Minimum Width	Recommended Width
Median for access control	4 feet	6 feet
Median for pedestrian refuge	6 feet	8 feet
Median for trees and lighting	6 feet [1]	10 feet [2]
Median for single left-turn lane	10 feet [3]	10 feet [2]
Median for single left-turn lane and pedestrian refuge	16 feet [4]	16 feet

[1] Six feet measured curb face to curb face is generally considered the minimum width for proper growth of small caliper trees (less than 4 inches).

[2] Wider medians provide room for larger caliper trees with better shade and more extensive landscaping.

[3] A 10-foot median provides for a turn lane without a concrete traffic separator.

[4] Includes a 10-foot turn lane and a 6-foot pedestrian refuge.



SAMPLE CROSS SECTIONS

Local governments that are developing new subdivisions or brand new streets through second-generation development (see Chapter 15, “Retrofitting Suburbia”) can create new street standards based on the information above. Sample curb-to-curb cross sections for the basic street typologies are shown in the diagrams below. These are only samples; other cross sections using the above guidance are also acceptable. When adopting standards for new streets, local jurisdictions should also include the sidewalks as an integral part of the street and use the guidance provided in Chapter 7, “Universal Pedestrian Access.” In built out areas (most of Broward County that is within the T-3 to T-6 context), rigid street standards are impractical because curb-to-curb widths are already set. In these cases, local governments should reconfigure streets by reassigning space to make streets more closely meet the principles of complete streets presented herein. The following diagrams provide examples of how some of these apply.

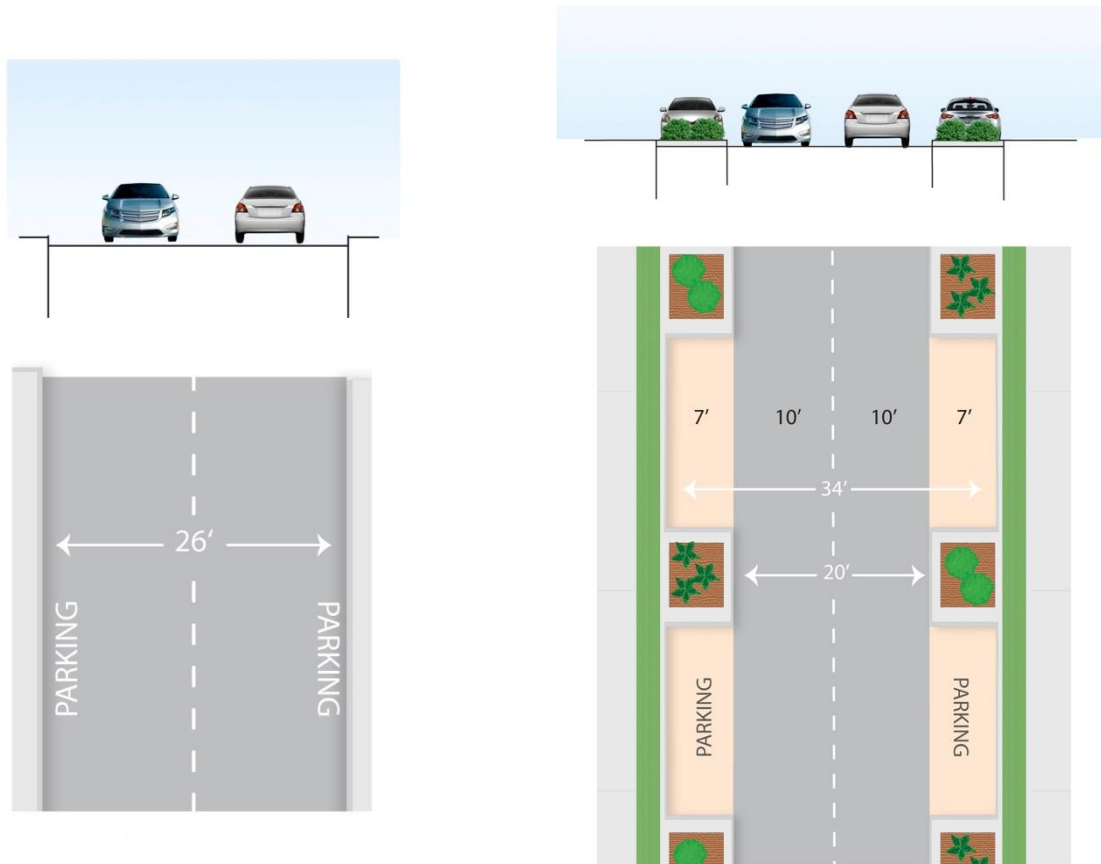

*Residential street*

*Residential street with inset parking*

SAMPLE CROSS SECTIONS

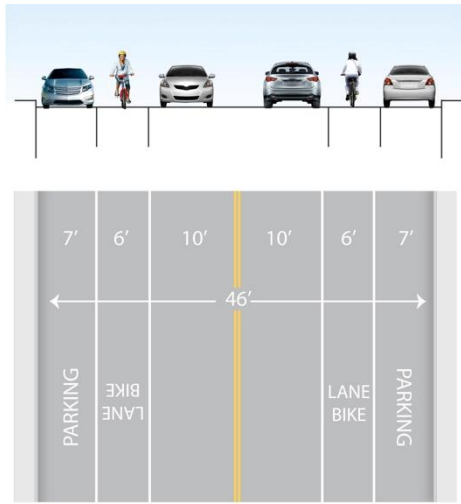

*Avenue*

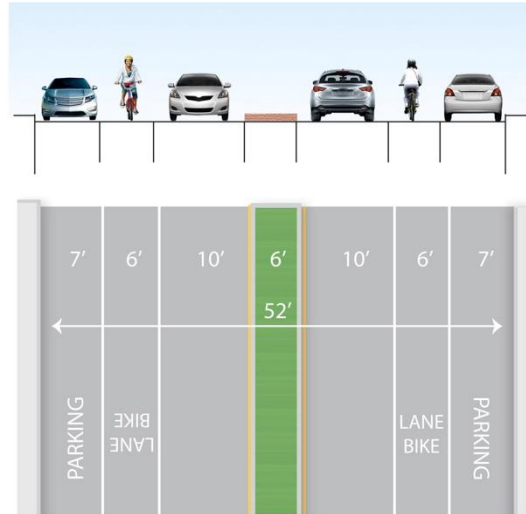

*Avenue with median*

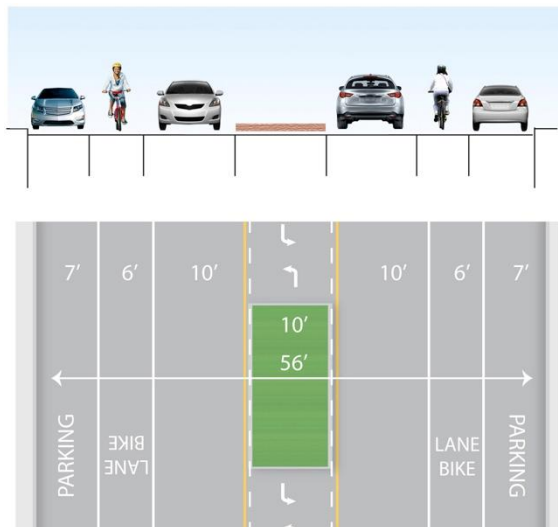

*Avenue with medians interspersed with turn lanes*

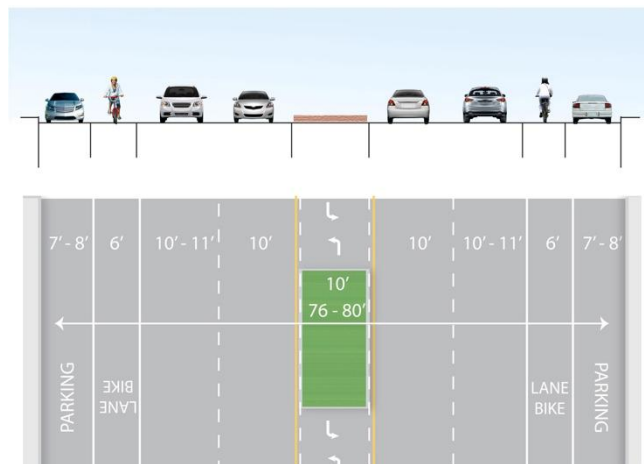

*5-Lane Boulevard*



SAMPLE CROSS SECTIONS

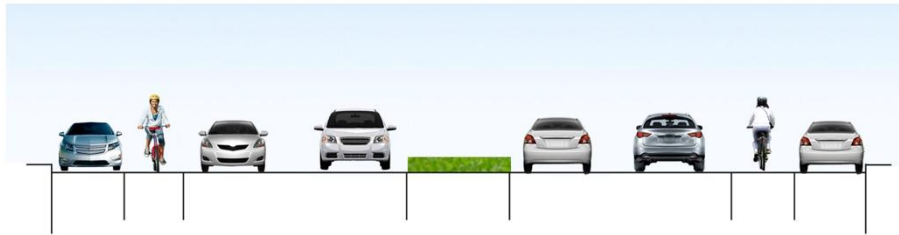

4-Lane Boulevard with colored bike lanes and inset parking

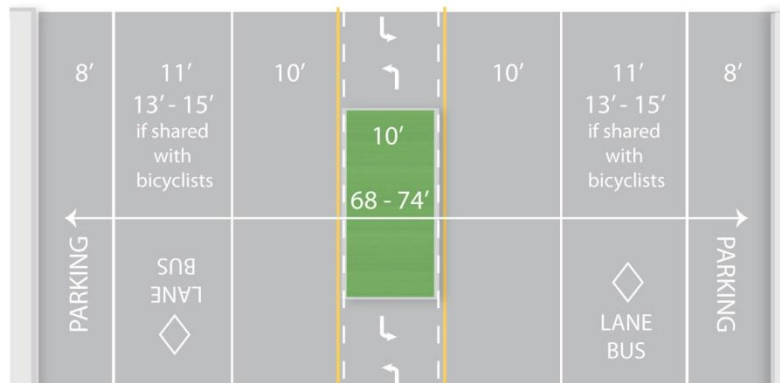
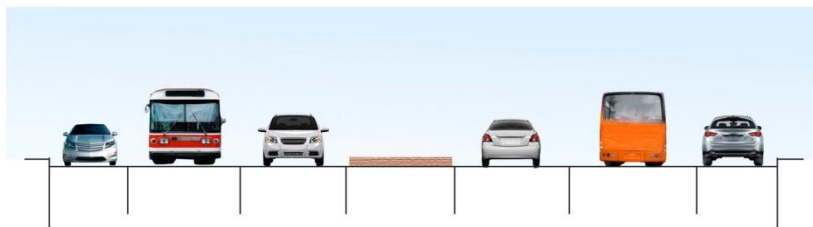

3-Lane Boulevard with bus lanes

Sample standard street cross sections  
(Credit: Michele Weisbart)



SAMPLE CROSS SECTIONS

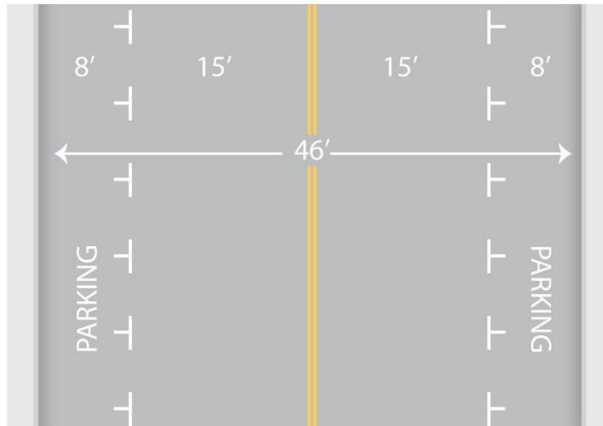

Existing 46'-wide avenue

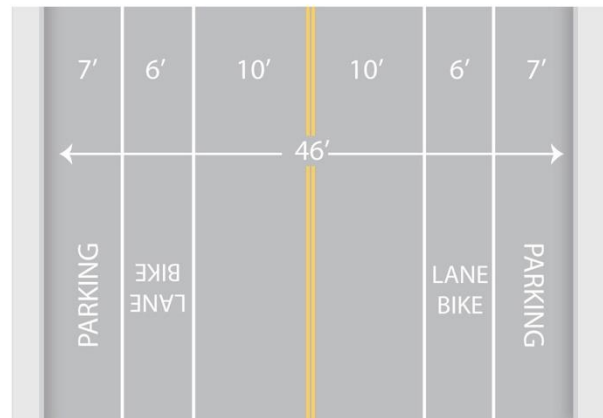

Restripe to add bike lanes



SAMPLE CROSS SECTIONS

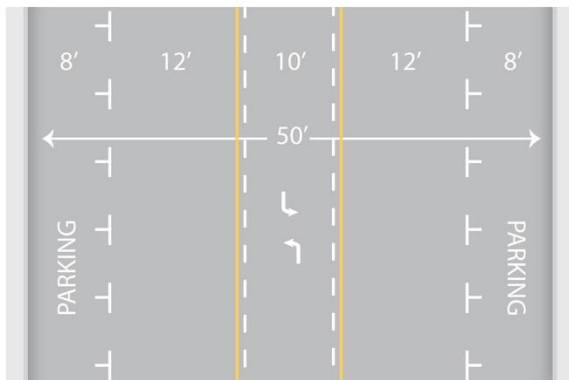
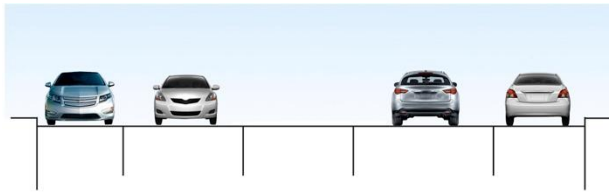

Existing 50' avenue

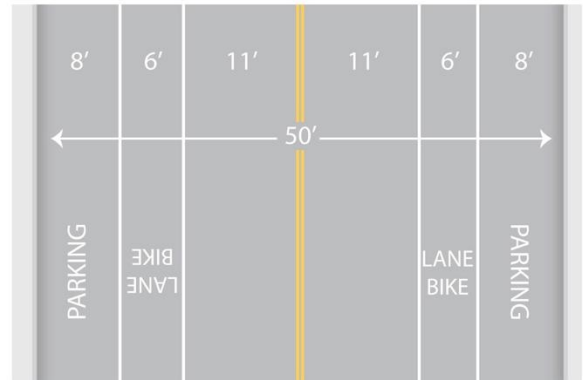

Option 1: Restripe to add bike lanes

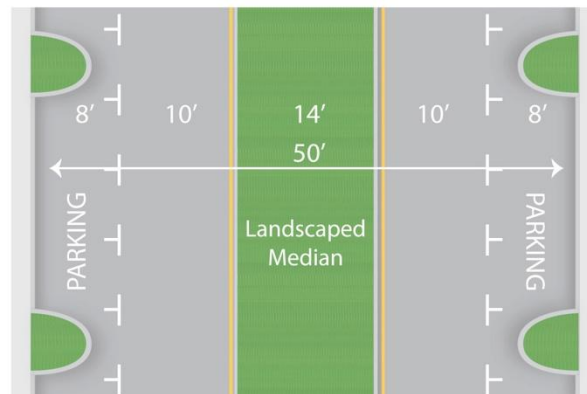
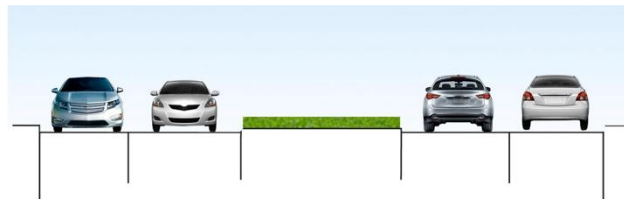

Option 2: Add median



SAMPLE CROSS SECTIONS

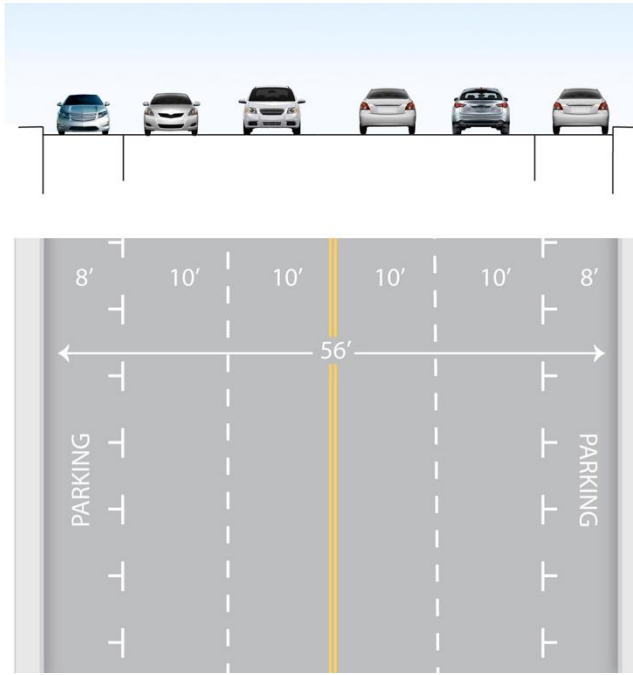

Existing 56'-wide main street

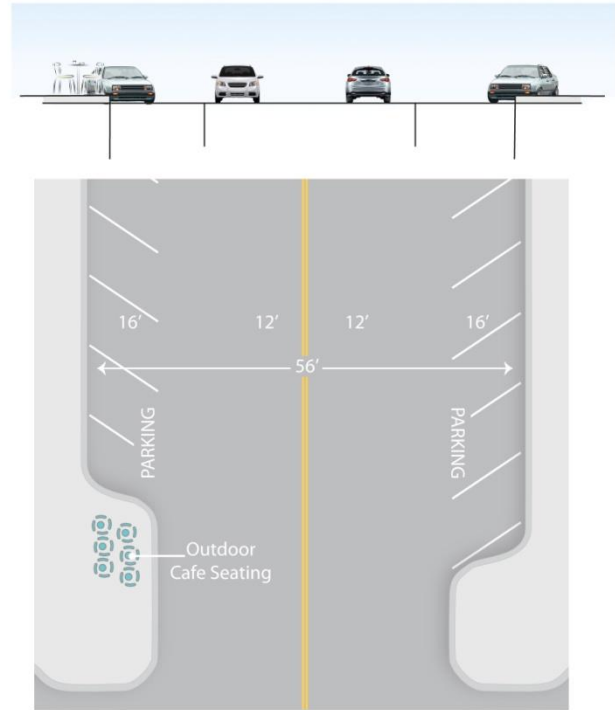

Reduce travel lanes and add reverse-in angled parking with curb extensions large enough for café seating



SAMPLE CROSS SECTIONS

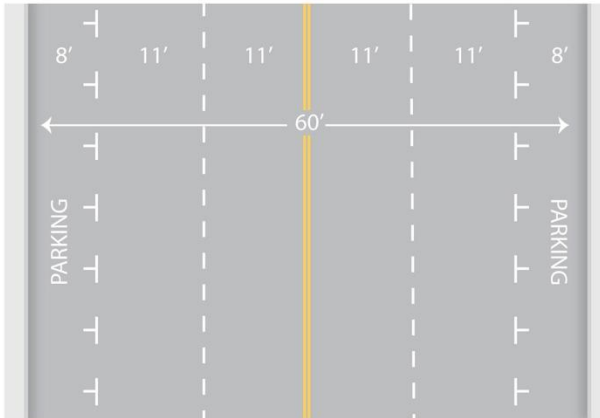
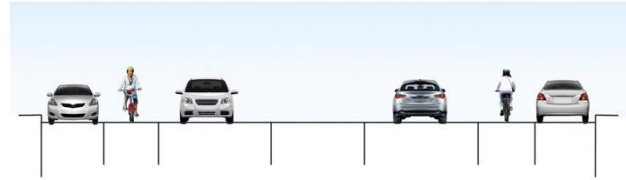

Existing 60'-wide avenue or boulevard

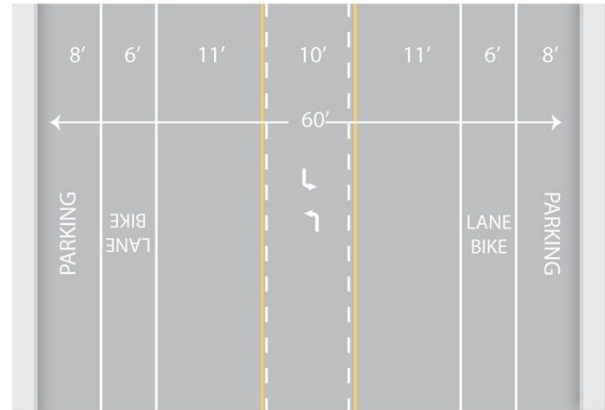

Option 1: Reduce travel lanes and add bike lanes

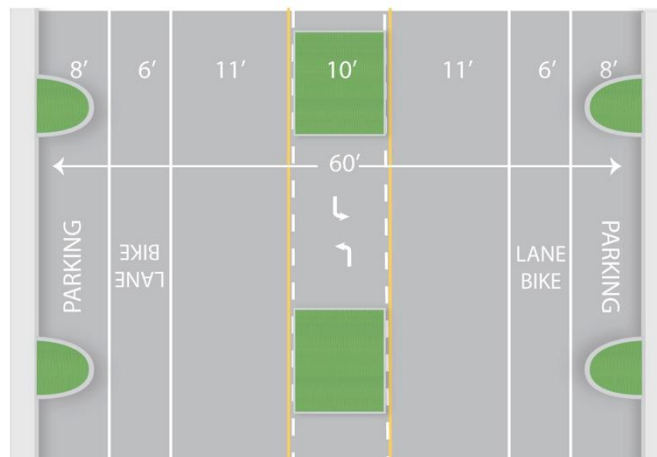
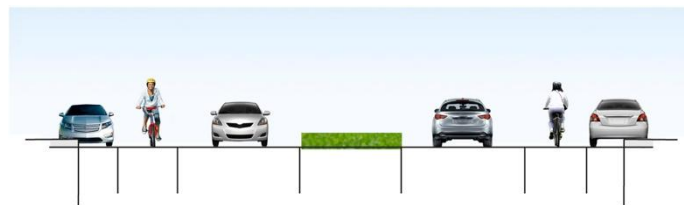

Option 2: Reduce travel lanes and add median islands interspersed with turn lanes; add interspersed landscaped curb extensions to inset parking

SAMPLE CROSS SECTIONS

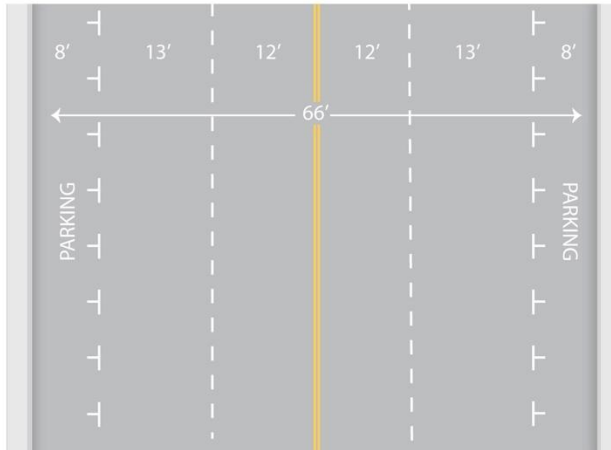

*Existing 66'-wide boulevard*

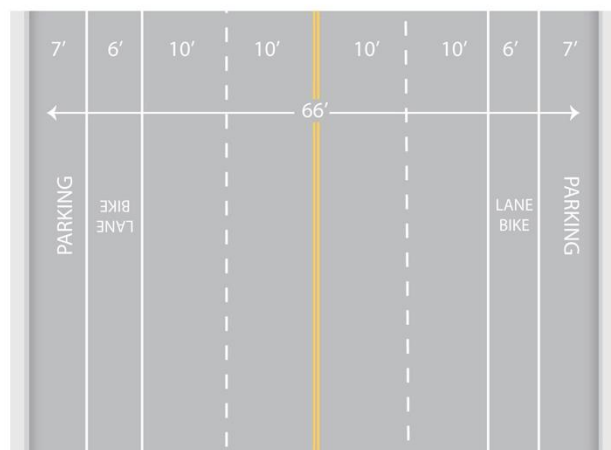

*Narrow travel lanes to add bike lanes*

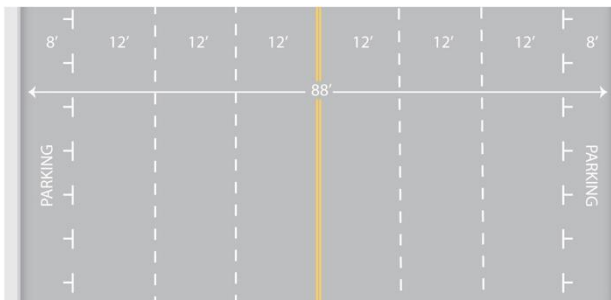
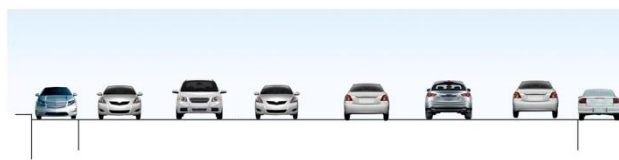

*Existing 88'-wide boulevard*

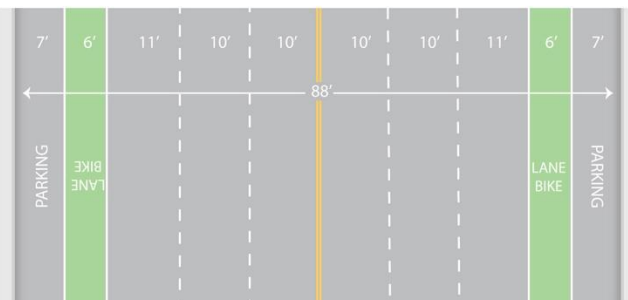

*Narrow travel lanes to add colored bike lanes*

*Sample redesigned street cross sections  
 (Credit: Michele Weisbart)*



## OTHER GEOMETRIC DESIGN ELEMENTS

### VERTICAL ALIGNMENT

The American Association of State Highway and Transportation Officials (AASHTO) *Geometric Design of Highways and Streets* manual (AASHTO Green Book) provides acceptable values for designing vertical curves for complete streets. The values used in design of vertical curve design should be selected based on the design speed appropriate for the context of the street. Using higher values can contribute to increased vehicle speeds and may require increased modification to the natural terrain, increasing negative impacts to the natural environment.

### HORIZONTAL ALIGNMENT

The AASHTO Green Book provides appropriate values for designing horizontal curves for complete streets. The values used in horizontal curve design should be selected based on the design speed appropriate for the context of the street. Using higher values can contribute to increased vehicle speeds and also impacts the character of the street. Larger horizontal curves also create a more “suburban” or “rural” highway feel.

### TRANSITION DESIGN

Transitions refer to a change in context, right-of-way width, number of lanes, neighborhoods, or districts. Multi-modal accommodations should be continuous through transitions. If the purpose of the transition is to change context, neighborhood, or district, then the designer should provide a transition speed zone, visual cues to changes in context or environment, and change the width of the traveled way or travel lanes as appropriate for the context.

### SIGHT DISTANCE

#### Stopping Sight Distance

The AASHTO Green Book provides appropriate values for designing stopping sight distance for complete streets. The 2004 AASHTO *Guide for Achieving Flexibility in Highway Design* is based on the latest research concerning the establishment of stopping sight distance. The document states that the established values for stopping sight distance are very conservative and provide adequate flexibility without creating increased crash risk. Consequently, appropriate design speed selection is critical to avoid overly negative impacts such as unnecessarily limiting on-street parking and tree planting.



### Intersection Sight Distance

Intersection sight distance should be calculated in accordance with the AASHTO Green Book using the design speed appropriate for the street being evaluated. When executing a crossing or turning maneuver onto a street after stopping at a stop sign, stop bar, or crosswalk, drivers will move slowly forward to obtain sight distance (without intruding into the crossing travel lane) stopping a second time as necessary. Therefore, when curb extensions are used or on-street parking is in place, the vehicle can be assumed to move forward on the second step movement, stopping just shy of the travel lane, increasing the driver's potential to see further than when stopped at the stop bar. As a result, the increased sight distance provided by the two step movement allows parking to be located closer to the intersection.

### HORIZONTAL CLEARANCE/CLEAR ZONE

Horizontal clearance is the lateral distance from a specified point on the roadway, such as the edge of the travel lane or face of the curb, to a roadside feature or object. The clear zone is the relatively flat unobstructed area that is to be provided for safe use by errant vehicles.

In urban areas, horizontal clearance based on clear zone requirements for rural and suburban highways is not practical because urban areas are characterized by more bicyclists and pedestrians, lower speeds, more dense abutting development, closer spaced intersections and accesses to property, higher traffic volumes, and restricted right-of-way. Therefore, streets with curbs and gutters in urban areas do not have sufficiently wide roadsides to provide clear zones. Consequently, while there are specific horizontal clearance requirements for these streets, they are based on clearances for normal operation and not based on maintaining a clear roadside for errant vehicles. The minimum horizontal clearance is 1.5 feet measured from the face of the curb. This is primarily intended for sign posts, and bicycle parking racks, so they aren't hit by large vehicles with overhangs maneuvering close to the curb. The desired horizontal clearance for bicycle parking racks is 4 feet to minimize the likelihood that a bicycle parked at the rack will not be struck by a vehicle overhang maneuvering close to the curb.

### TRAVELED WAY LIGHTING

Pedestrians are disproportionately hit when visibility is poor: at dusk, night, and dawn. Many crossings are not well lit. Providing illumination or improving existing lighting increases nighttime safety at intersections and midblock crossings, as motorists can better see pedestrians. Pedestrian scale lighting along sidewalks provides greater security, especially for people walking alone at night.

Transit stops require both kinds of lighting: strong illumination of the traveled way for safer street crossing, and pedestrian scale illumination at the stop or shelter for security. FHWA-HRT-08-053, *Informational Report on Lighting Design for Midblock Crosswalks*, (April 2008) is a good resource. It also contains useful information about lighting design for pedestrians at intersections.



If bus stops are present between roadway sections, it is necessary to illuminate the roadway and the bus stop. The lighting at the bus stop is essential to provide safety for transit users. Bus stops have high pedestrian activity; therefore, it is necessary to provide adequate lighting at these facilities.

## MODEL PROJECT

### LA JOLLA

La Jolla Boulevard in the Bird Rock neighborhood of San Diego is an example of the conversion of a five-lane road. Due to parents' complaints that they had to drive their children across the road, a community charrette was organized in 2002. As a result, a new concept was developed that included a median, one 11-foot travel lane in each direction, park assist lanes next to the parallel parking lane on the east side, and a wider park assist lane next to the angled parking on the west side of the street. The five intersections that were controlled by two or four-way stop control and signals were converted to single lane roundabouts.

The project was opened in stages and completed in August 2008. Although the traffic volumes have decreased because of the recession from 22,000 vehicles per day to 17,000 vehicles per day, the pedestrian and bicycle volumes have increased enormously (City of San Diego traffic counts and traffic webcam, 2010).



*La Jolla Boulevard intersection before and after roundabout: San Diego, CA  
(Credit: Michael Wallwork)*

## ADDITIONAL RESOURCES

Institute of Transportation Engineers. *Designing Walkable Urban Thoroughfares : A Context Sensitive Approach*, 2010.



This page left blank intentionally.



## 6. INTERSECTION DESIGN

INTRODUCTION.....	1
ESSENTIAL PRINCIPLES OF INTERSECTION DESIGN.....	1
INTERSECTION GEOMETRY .....	2
Intersection Skew.....	3
Corner Radii .....	4
Curb Extensions.....	7
Crosswalk and Ramp Placement.....	10
On-Street Parking Near Intersections .....	13
Right-Turn Channelization Islands .....	13
YIELD AND STOP CONTROLLED INTERSECTIONS .....	16
SIGNALIZED INTERSECTIONS .....	16
Operational Design.....	17
Phasing.....	17
ROUNDBABOUTS.....	22
Advantages and Disadvantages .....	23
General Design Elements of Roundabouts.....	24
Roundabout Design Criteria .....	25
Operations and Analysis .....	26
Single-Lane Roundabouts .....	26
Multi-Lane Roundabouts.....	27
Mini-Roundabouts .....	28
Neighborhood Traffic Circles .....	29



*(Credit: Kimley-Horn and Associates, Inc.)*



## INTRODUCTION



*Lively intersection (Credit: Dan Burden)*

Most conflicts between roadway users occur at intersections, where travelers cross each other's path. Good intersection design indicates to those approaching the intersection what they must do and who has to yield. Exceptions to this include places where speeds are low (typically less than 20 mph) or where a shared space design causes users to approach intersections with caution. Conflicts for pedestrians and bicyclists are exacerbated due to their greater vulnerability, lesser size, and reduced visibility to other users. Multimodal intersections operate with pedestrians, bicycles, cars, buses, trucks, and in some cases,

trains. The diverse uses of intersections involve a high level of activity and shared use. Intersections have the unique characteristic of accommodating the almost constant occurrence of conflicts between all modes, and most collisions on major thoroughfares take place at intersections. This characteristic is the basis for most intersection design standards, particularly for safety. Designing multimodal intersections with the appropriate accommodations for all users is performed on a case-by-case basis. The designer should begin with an understanding of the community objectives and priorities related to design tradeoffs.

This chapter describes design considerations in intersection geometry and intersection signalization, as well as roundabouts and other features to improve safety, accessibility, and mobility for all users. The benefits and constraints of each feature are examined and the appropriate use and design of each feature are described.

## ESSENTIAL PRINCIPLES OF INTERSECTION DESIGN

The following intersection design principles apply to serve all users of intersections:

- Good intersection designs are compact.
- Minimize conflicts between modes.
- Unusual conflicts should be avoided.
- Accommodate all modes with appropriate levels of service.
- Simple right-angle intersections are best for all users since many intersection problems are worsened at skewed and multi-legged intersections.
- Free-flowing movements should be avoided.

***"Busy streets are not friendly to cross."***

- (Broward Complete Streets survey respondent)



- Avoid elimination of travel modes from the typical section due to intersection design constraints.
- Access management practices should be used to remove additional vehicular conflict points near the intersection.
- Signal timing should consider the safety and convenience of all users and should not hinder bicycle or foot traffic with overly long waits or insufficient crossing times.
- Ensure intersections are fully accessible.



*Intersections should be designed to serve all types of users comfortably, even on wide arterial boulevards (Credit: Kimley-Horn and Associates, Inc.)*

## INTERSECTION GEOMETRY

Intersection geometry is a critical element of intersection design, regardless of the type of traffic control used. Geometry sets the basis for how all users traverse intersections and interact with each other. The principles of intersection geometry apply to both street intersections and freeway on- and off-ramps.

Intersection layout is primarily comprised of the alignment of the legs; width of traffic lanes, bicycle lanes, and sidewalks on each approach (number of lanes, median and roadside elements); and the method of treating and channelization of turning movements. The design of an intersection's layout requires a balance between the needs of pedestrians, bicyclists, vehicles, freight and transit in the available right-of-way.



Intersections are comprised of a physical area. The functional area is where drivers make decisions and maneuver into turning movements. The three parts of a functional area include the perception-reactions distance, maneuver distance and storage distance. AASHTO's *Policy on Geometric Design of Highways and Streets*, addresses the issues and provides guidance for the detail geometric design of the functional area. The basic types of intersections in urban contexts include the T-intersection, cross intersection, multi-leg intersection, and modern roundabout.

#### INTERSECTION SKEW

Skewed intersections are generally undesirable and introduce the following complications for all users:

- The travel distance across the intersection is greater, which increases exposure to conflicts and lengthens signal phases for pedestrians and vehicles.
- Skews require users to crane their necks to see other approaching users, making it less likely that some users will be seen.
- Obtuse angles encourage speeding.

To alleviate the problems with skewed intersections, several options are available:

- Every reasonable effort should be made to design or redesign the intersection closer to a right angle. Some right-of-way may have to be purchased, but this can be offset by the larger area no longer needed for the intersection, which can be sold back to adjoining property owners or repurposed for a pocket park, rain garden, greenery, etc.
- Converting stop-controlled and signalized intersections into modern roundabouts. Roundabouts' benefits include improved safety, speed reduction, aesthetics and operational functionality and capacity.
- Pedestrian refuges should be provided if the crossing distance exceeds approximately 40 feet.
- General use travel lanes and bike lanes may be striped with dashes to guide bicyclists and motorists through a long undefined area.

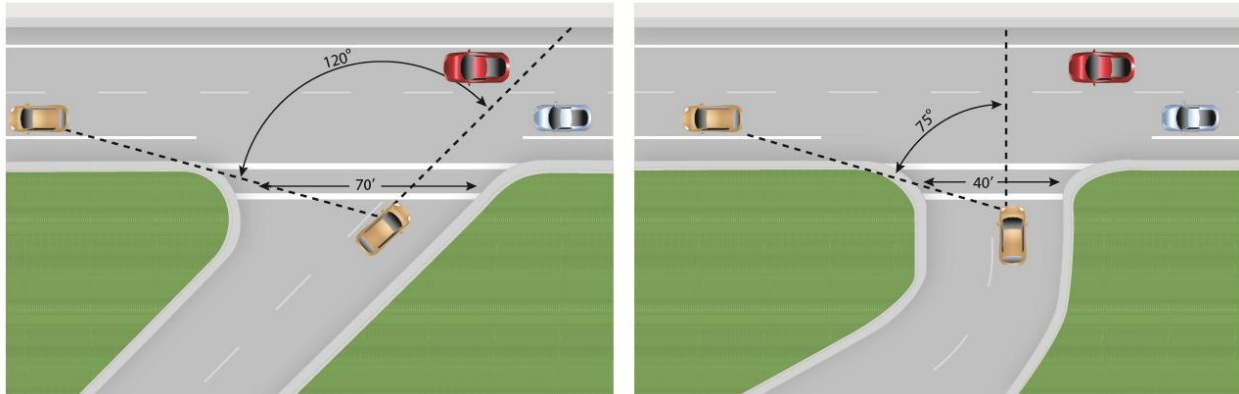

*Realigning the skewed intersection in the graphic on the left to the right-angle connection in the graphic on the right results in less exposure distance and better visibility for all users.  
(Credit: Michele Weisbart)*

Multi-leg intersections (more than two approaching roadways) are generally undesirable. Making it clear to drivers that pedestrians use the intersections, and providing proper indication to pedestrians where the best place is to cross are some of the problems with this type of intersections. Multi-leg intersections also present the following complications for all users:

- Multiple conflict points are added as users arrive from several directions.
- Users may have difficulty assessing all approaches to identify all possible conflicts.
- At least one leg will be skewed.
- Users must cross more lanes of traffic and the total travel distance across the intersection is increased.

To alleviate the problems with multi-leg intersections, several options are available:

- Every reasonable effort should be made to design the intersection so there are no more than four legs. This is accomplished by removing one or more legs from the major intersection and creating a minor intersection further up or downstream.
- As an alternative, one or more of the approach roads can be closed to motor vehicle traffic, while still allowing access for pedestrians and bicyclists.
- Roundabouts should be considered.
- Pedestrian refuges should be created if the crossing distance exceeds approximately 40 feet.
- General use travel lanes and bike lanes may be striped with dashes to guide bicyclists and motorists through a long undefined area.

## CORNER RADII

Corner radii (also called curb return radii) are the curved connection of curbs in the corners. This intersection geometry feature has a significant impact on the comfort and safety of non-



motorized users. The use of the smallest practical corner radii to shorten the length of the crosswalk is usually desirable. Small corner radii provide the following benefits:

- Smaller, more pedestrian-scale intersections resulting in shorter crossing distances
- Slower vehicular turning speeds
- Reduced pedestrian crossing distance and crossing time
- Better geometry for installing perpendicular ramps for both crosswalks at each corner
- Simpler, more appropriate crosswalk placement, in line with the approaching sidewalks

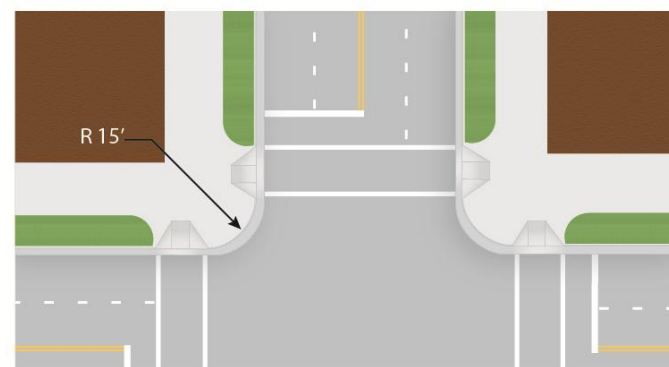
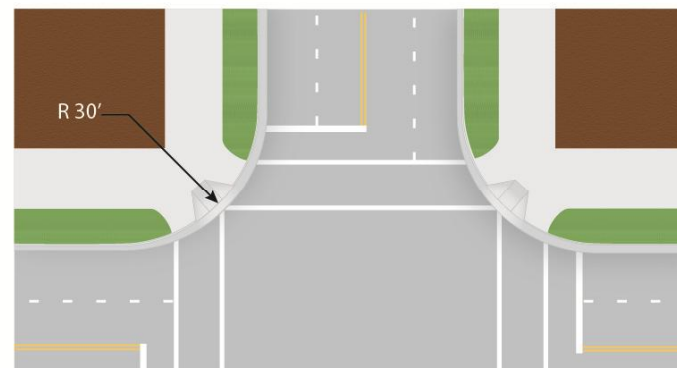
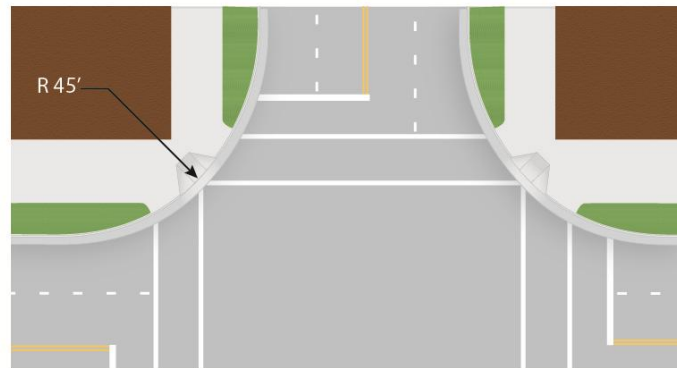

*Tighter corner radii reduce crossing distance and slow turning traffic.  
(Credit: Michele Weisbart)*



- When designing corner radii for complete streets, the default design vehicle should be the passenger (P) vehicle. Therefore, the default corner radius is 15 feet. Larger design vehicles should be used only where they are known to regularly make turns at the intersection, and corner radii should be designed based on the larger design vehicle traveling at crawl speed. In addition, designers should consider the effect that bicycle lanes and on-street parking have on the effective radius, increasing the ease with which large vehicles can turn.

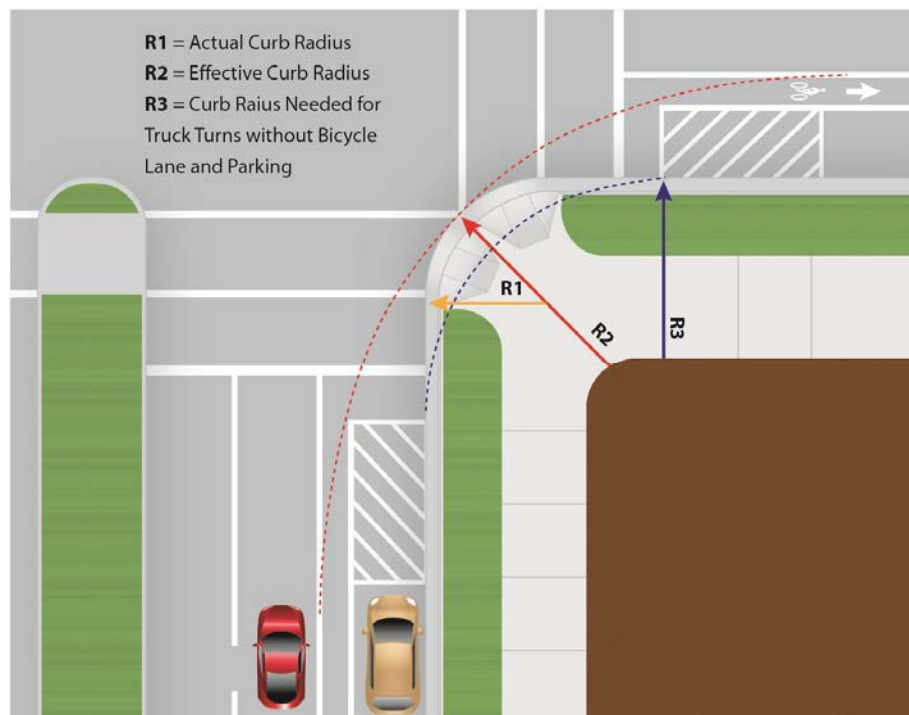

*The effective corner radius controls turning speeds and the ability of large vehicles to turn.  
(Credit: Michele Weisbart)*

- Encroachment by large vehicles is acceptable onto multiple receiving lanes. When a design vehicle larger than the passenger (P) vehicle is used, the truck or bus should be allowed to turn into all available receiving lanes. As described in Chapter 5, “Traveled Way Design,” larger, infrequent vehicles (the “control vehicle”) can be allowed to encroach on multiple departure lanes and partway into opposing traffic lanes.
- Corner radii may need to be larger where occasional encroachment is not acceptable.

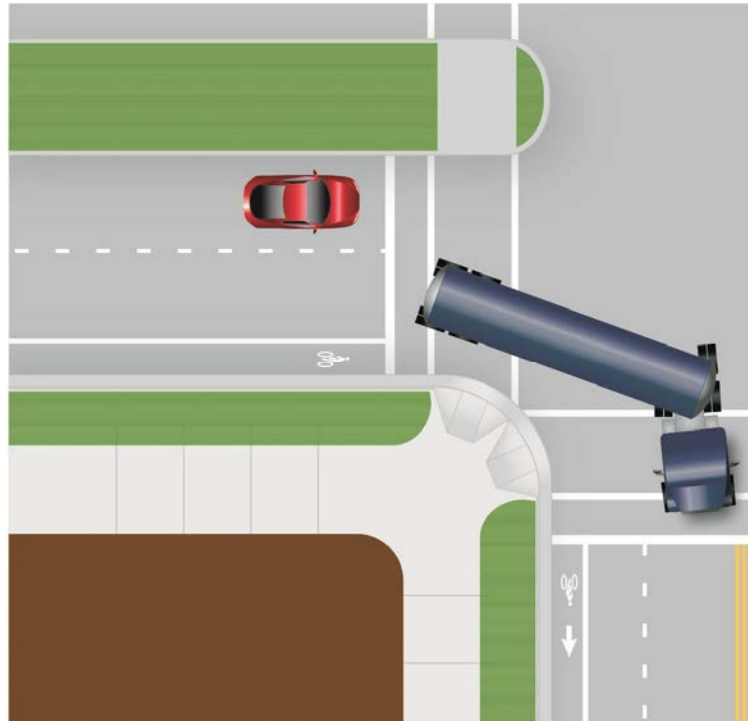

*Corner radii can be kept smaller by allowing trucks and buses to turn into multiple receiving lanes.  
(Credit: Michele Weisbart)*

## CURB EXTENSIONS

Where on-street parking is allowed, curb extensions (also called bulb-outs) should replace the parking lane at crosswalks. Curb extensions should be the same width as the parking lane. The appropriate corner radius should be applied based on the guidance in the section above. Due to reduced road width, the corner radius on a curb extension may need to be larger than if curb extensions were not installed.

Curb extensions offer many benefits related to livability:

- Reduced pedestrian crossing distance resulting in less exposure to vehicles and shorter pedestrian clearance intervals at signals
- Improved visibility between pedestrians and motorists
- A narrowed roadway, which has a potential traffic calming effect
- Additional room for street furniture, landscaping, and curb ramps
- Slower turning vehicles
- Additional on-street parking potential due to improved sight lines at intersections. Since curb extensions allow pedestrians to walk out toward the edge of the parking lane without entering the roadway, pedestrians can better see vehicles and motorists can better see pedestrians.
- Management of streetwater runoff
- Separate parking maneuvers from turning vehicles.



Parked Vehicles Decrease Sight Distance

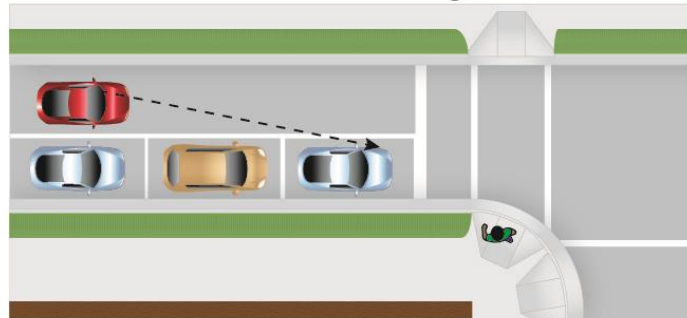

Parked Setback for Sight Distance

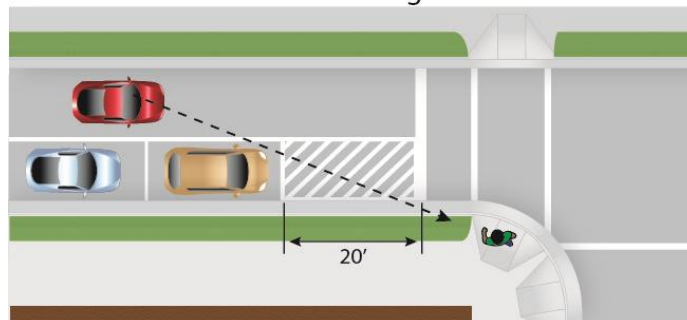

Curb Extension Improves Sight Distance

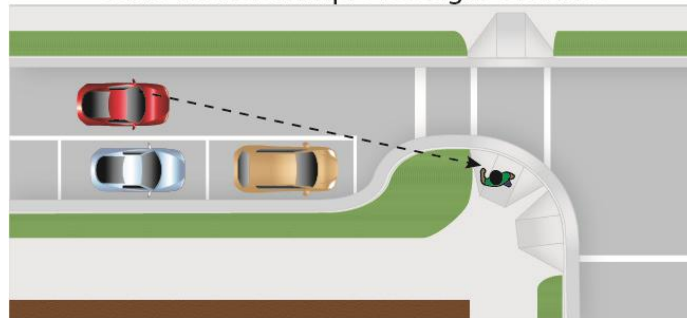

*Curb extensions improve sight distance between pedestrians and motorists, possibly allowing additional on-street parking.  
(Credit: Michele Weisbart)*

To fully achieve livability goals, the curb extension and parking area can be integrated into the furniture zone portion of the sidewalk corridor. This technique involves using similar surface materials for the curb extension, parking area, and the sidewalk as shown in the figure below. Instead of the curb extensions appearing to jut out into the street, the parking appears as “parking pockets” in the furniture zone. Curb extensions can be used in any context zone, but they should be standard in T-5 and T-6. Curb extensions must always be outside of the width of the bike lane or the location within the traveled way that bicyclists are expected to ride.

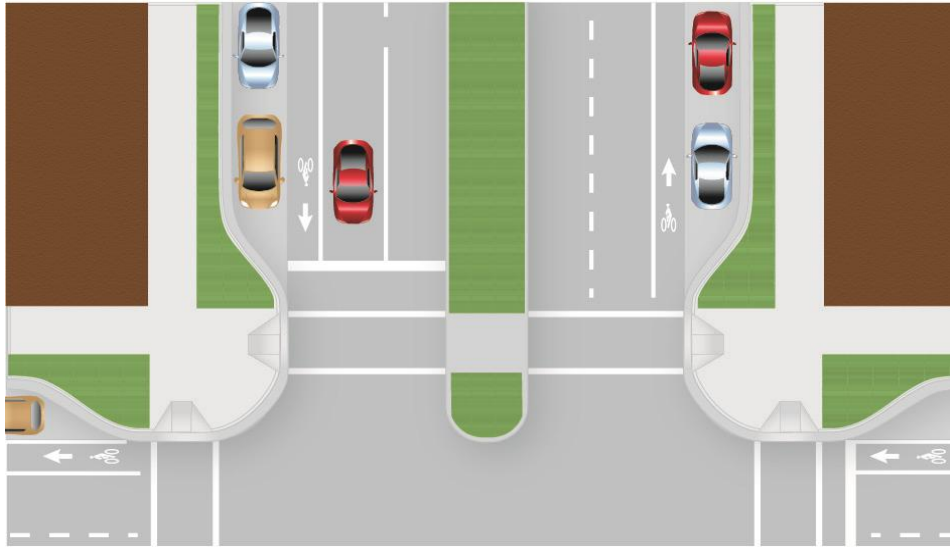

*Integrating curb extensions and on-street parking into the sidewalk corridor enhances pedestrian safety and the walking experience. (Credit: Michele Weisbart)*

To reinforce this design where street grades permit, the gutter line and drainage grates should be placed between the travel lane and the parking lane/curb extensions. This is called a “valley gutter” and creates a stronger visual cue separating the parking lane from the bicycle lane or travel lane. It can sometimes allow existing drainage infrastructure to be left in place.

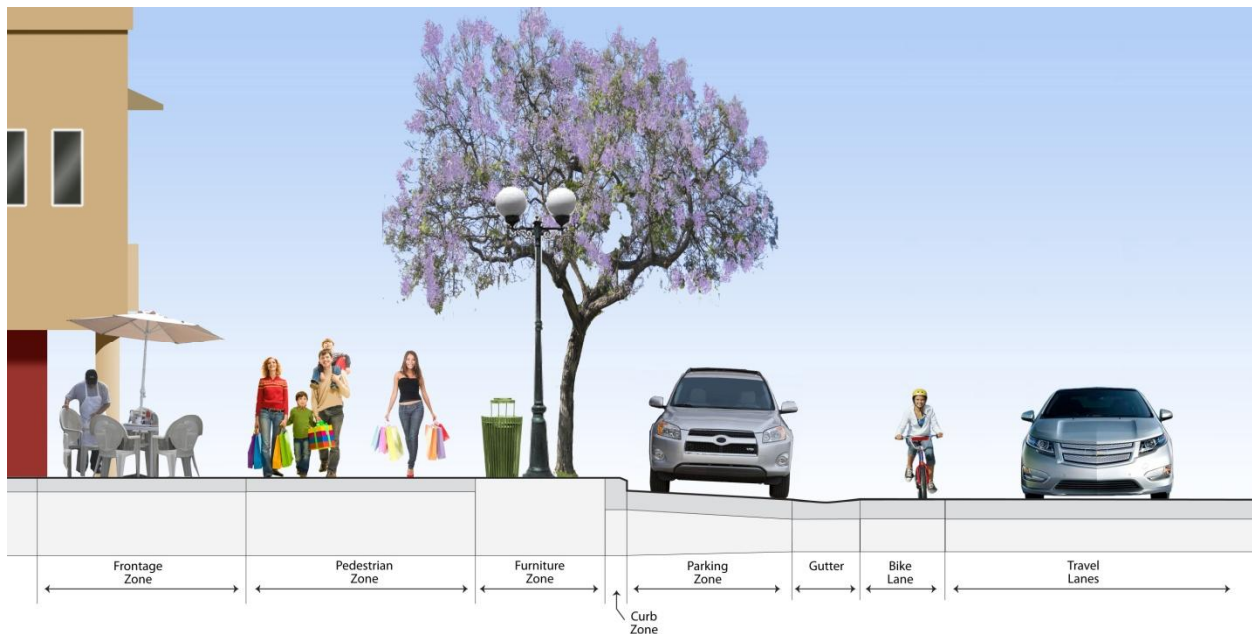

*An example of integrating curb extensions and parking into the sidewalk corridor by placing a valley gutter between the parking and the traveled way. (Credit: Michele Weisbart)*



## CROSSWALK AND RAMP PLACEMENT

Crosswalks are used to assist pedestrians in crossing the street. *Florida State Statute 316* makes it clear that unmarked crosswalks can exist only at intersections whereas marked crosswalks can exist at intersections or elsewhere. This is consistent with the Manual on Uniform Traffic Control Devices (MUTCD). Crosswalks and ramps at intersections should be placed so they provide convenience and safety for pedestrians. The following recommended practices will help achieve these goals:

- Allow crossings on all legs of an intersection, unless there are no pedestrian accessible destinations on one or more of the corners. Closing a crosswalk usually results in a pedestrian either walking around several legs of the intersection, exposing them to more conflicts, or crossing at the closed location, with no clear path or signal indication as to when to cross.
- Provide marked crosswalks at signalized intersections.
- Provide marked crosswalks at an intersection approach controlled by stop sign.
- Marked crosswalks shall be 10 feet wide in urban zones.
- Strongly consider providing marked crosswalks at major unsignalized intersections with medians for pedestrian refuges or on one-way streets.
- Place crosswalks as close as possible to the desire line of pedestrians, which is generally in line with the approaching sidewalks.
- Provide as short as possible a crossing distance to reduce the time that pedestrians are exposed to motor vehicles; this is usually as close as possible to right angles across the roadway, except for skewed intersections.
- Ensure that there are adequate sight lines between pedestrians and motorists. This typically means that the crosswalks should not be placed too far back from the intersection.
- When a raised median is present, extend the nose of the median past the crosswalk with a cut-through for pedestrians.
- Provide one ramp per crosswalk (two per corner for standard intersections with no closed crosswalks). Ramps must be entirely contained within a crosswalk (the crosswalk can be flared to capture a ramp that cannot be easily relocated). Align the ramp run with the crosswalk when possible, as ramps that are angled away from the crosswalk may lead some users into the intersection.



- At intersections where roads are skewed or where larger radii are necessary for trucks, it can be difficult to determine the best location for crosswalks and sidewalk ramps. In these situations, it is important to balance the recommended practices above. Tighter curb radii make implementing these recommendations easier.
- At signalized crossings, shared-use path crossing, or any other particular high emphasis crosswalk markings (ladder style crosswalk) should be used to increase visibility.
- Curb ramp opening on shared-use path shall be the same width as the path itself.
- Detectable warning surfaces shall be provided per MUTCD 3B.18 and 49 Code of Federal Regulations Part 37.



*Pedestrian warning sign (W11-2) at a high emphasis crosswalk. Note the yield bars (series of isosceles triangles painted on the approach to the crosswalk).  
(Credit: Kimley-Horn and Associates, Inc.)*

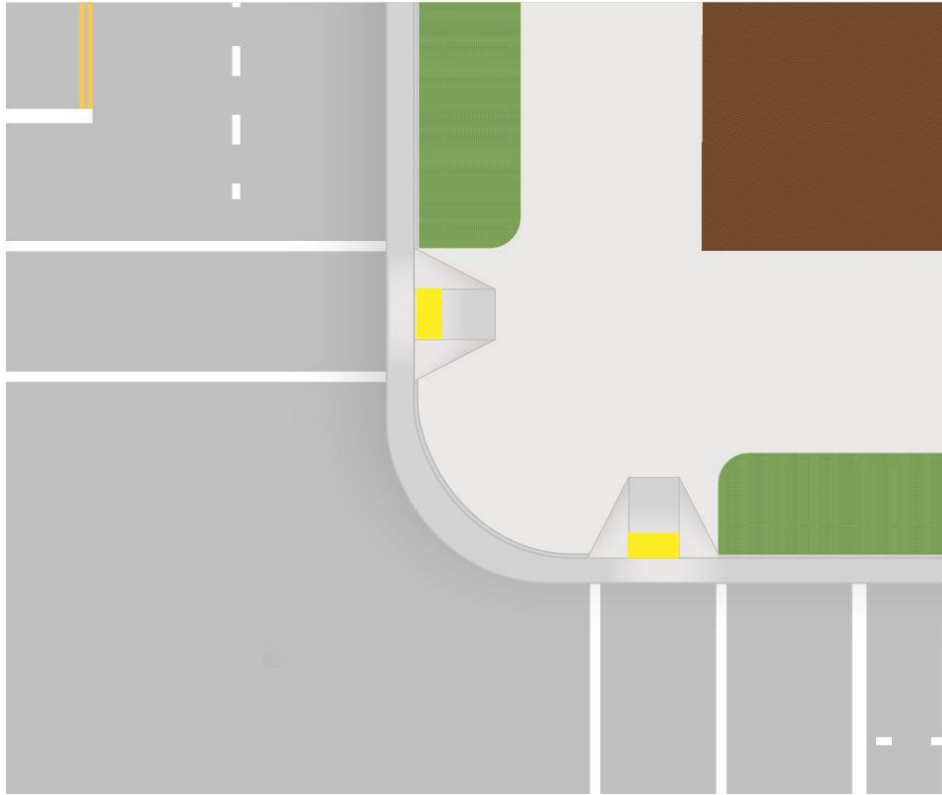

*One curb ramp per crosswalk should be provided at corners. Ramps should align with sidewalks and crosswalks.  
(Credit: Michele Weisbart)*



## ON-STREET PARKING NEAR INTERSECTIONS

On-street parking should be positioned far enough away from intersections based on providing adequate sight distance to allow for good visibility of pedestrians preparing to cross the street. Curb extensions allow parking to be placed closer to the intersection since pedestrians can queue in a more visible location for which parked cars do not block the sight line of an oncoming motorist.

## RIGHT-TURN CHANNELIZATION ISLANDS

In the context suburban zone (T3) through urban core zone (T6), high speed channelized right-turns are inappropriate because they create conflicts with pedestrians. Right-turn lanes should generally be avoided as they increase the size of the intersection, the pedestrian crossing distance, and the likelihood of right-turns-on-red by inattentive motorists who do not notice pedestrians on their right. However, where there are heavy volumes of right turns (approximately 200 vehicles per hour or more), a right-turn lane may be the best solution to provide additional vehicle capacity without adding additional lanes elsewhere in the intersection. For turns onto roads with only one through lane and where truck turning movements are rare, providing a small corner radius at the right-turn lane often provides the best solution for pedestrians' safety and comfort.

At intersections of multi-lane roadways where trucks make frequent right turns, a raised channelization island between the through lanes and the right-turn lane is a good alternative to an overly large corner radius and enhances pedestrian safety and access. If designed correctly, a raised island can achieve the following objectives:

- Allow pedestrians to cross fewer lanes at a time
- Allow motorists and pedestrians to judge the right turn/pedestrian conflict separately
- Reduce pedestrian crossing distance, which can improve signal timing for all users
- Balance vehicle capacity and truck turning needs with pedestrian safety
- Provide an opportunity for landscape and hardscape enhancement

The following design practices for right-turn lane channelization islands should be used to provide safety and convenience for pedestrians, bicyclists, and motorists:

- The provision of a channelized right-turn lane is appropriate only on signalized approaches where right-turning volumes are high or large vehicles frequently turn and conflicting pedestrian volumes are low .
- Provide accessible islands for refuge.
- Provide a yield sign for the channelized right-turn lane.
- Tighter angles are preferred for multiple reasons.



- Provide at least a 60-degree angle between vehicle flows, which reduces turning speeds and improves the yielding driver's visibility of pedestrians and vehicles.
- Place the crosswalk across the right-turn lane about one car length back from where drivers yield to traffic on the other street, allowing the yielding driver to respond to a potential pedestrian conflict first, independently of the vehicle conflict, and then move forward, with no more pedestrian conflict.
- If vehicle-pedestrian conflicts are a significant problem in the channelized right-turn lane, it might be appropriate to provide signing to remind drivers of their legal obligation to yield to pedestrians crossing in the crosswalk. Regulatory signs such as the R10-15 sign from the MUTCD or warning signs such as the W11-2 sign could be placed in advance of or at the crossing location.
- Removing channelized right-turn lanes further assists pedestrians.



*This TURNING TRAFFIC MUST YIELD TO PEDESTRIANS AND BICYCLISTS sign is an R10-15 (modified). The modification is for use on shared-use paths.  
(Credit: Kimley-Horn and Associates, Inc.)*

These goals are best accomplished by creating an island that is roughly twice as long as it is wide. The corner radius will typically have a long radius (150 feet to 300 feet) followed by a short radius (20 feet to 50 feet). When creating this design, it is necessary to allow large trucks to turn into multiple receiving lanes. This design is often not practical for right-turn lanes onto roads with only one through lane. This right-turn channelization design is different from designs that provide free-flow movements (through a slip lane) where right-turning motorists turn into an exclusive receiving lane at high speed. Right turns should be signal-controlled in this situation to provide for a signalized pedestrian walk phase.



Traffic channelization is an effective mitigation strategy when intersection radii reduction is not an option.  
(Credit: Michele Weisbart)

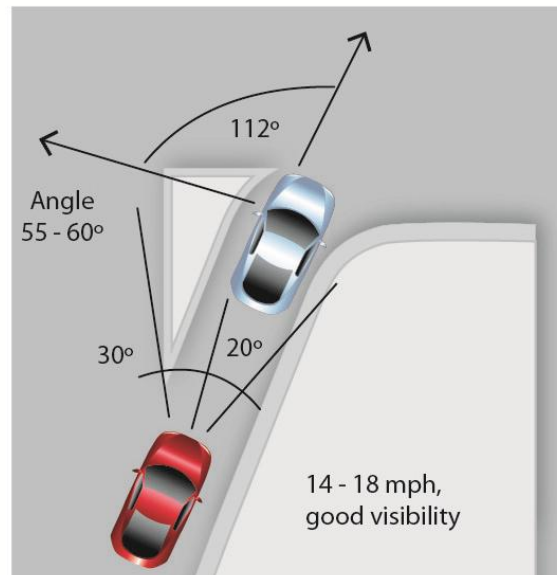
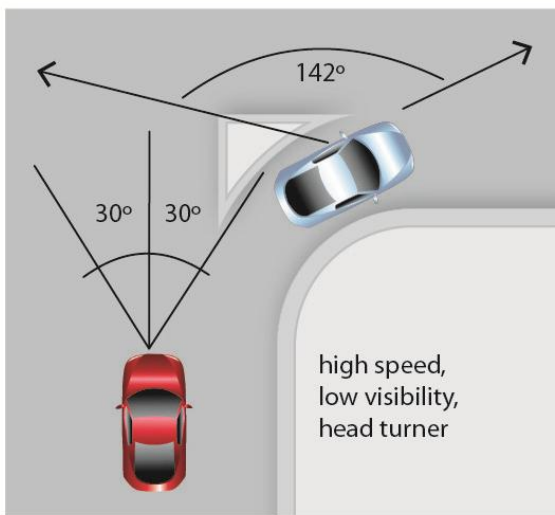

Sharper angles of slip lanes are important to slow cars and increase visibility  
(Credit: Michele Weisbart)



## YIELD AND STOP CONTROLLED INTERSECTIONS

Unsignalized intersection control options include the following:

- Yield control, which is under-utilized and should be considered to reduce unnecessary stops caused by the overuse of STOP signs.
- Uncontrolled intersections are yield controlled by default.
- Two-way stop control, which is the most common form of intersection control. This is an overused device. At many intersections a neighborhood traffic calming circle is a preferable and more effective option.
- All-way stops are often overused, incorrectly, to slow traffic. The use of all-way stops should be consistent with the MUTCD. At many intersections a neighborhood traffic calming circle is a preferable and a more effective option.
- Crosswalks may be marked consistent with *Florida State Statute 316*.

## SIGNALIZED INTERSECTIONS

Signalized intersections provide unique challenges and opportunities for livable communities and complete streets. On one hand, signals provide control of pedestrians and motor vehicles with numerous benefits. Where signalized intersections are closely spaced, signals can be used to control vehicle speeds by providing appropriate signal progression on a corridor. Traffic signals allow pedestrians and bicyclists to cross major streets with only minimal conflict with motor vehicle traffic. On the other hand, traffic signals create challenges for non-motorized users. Signalized intersections often have significant turning volumes, which conflict with concurrent pedestrian and bicycle movements. In many cases, roundabouts offer safer, more convenient intersection treatment than signals.

To improve livability and pedestrian safety, signalized intersections should meet the following principles:

- Provide signal progression at speeds that support the target speed of a corridor whenever feasible
- Provide short signal cycle lengths, which allow frequent opportunities to cross major roadways, improving the usability and livability of the surrounding area for all modes
- Ensure that signals detect bicycles through video detection zones for video monitoring or loop detectors in-pavement.
- Place pedestrian signal heads in locations where they are visible
- At locations with many crossing pedestrians, time the pedestrian phase to be on automatic recall, so pedestrians don't have to seek and push a pushbutton.
- Where few pedestrians are expected and automatic recall of walk signals is not desirable, place pedestrian pushbuttons in convenient locations, using separate pedestals if necessary. Use the recommendations regarding pushbutton placement for



accessible pedestrian signals found in the Manual on Uniform Traffic Control Devices (MUTCD).

- Include pedestrian signal phasing that increases safety and convenience for pedestrians, as discussed in more detail below.

## OPERATIONAL DESIGN

Approximately 2 percent of intersections are signalized, and approximately 20 percent of all intersection crashes occur at signalized intersections. Unfortunately, in many locations signalization is the only option because of right-of-way limitations, high vehicle volumes, and the need to create gaps to provide reasonable operation for all users.



*Pole-mounted signal  
(Credit: Ryan Snyder)*

Over the years, the most common signal hardware has transitioned from post-mounted signals to span-wire signals to overhead mast arms. This change has lifted drivers' eyes upward and created a situation in many east/west streets where drivers must look toward a rising or setting sun that can block vision of a signal. In urban areas the large mast arms are intrusive. As part of the conversion to healthier streets, changing to post-mounted signals in urban areas could lower the cost of installing and maintaining signals, reduce the vision intrusion, and help lower a driver's vision back to pedestrians. There are two primary advantages for pedestrians and bicyclists

to pole-mounted signals:

- Drivers have to stop back from the crosswalk to see the indication so they are less likely to encroach into the crosswalk, and more likely to see pedestrians and bicyclists when turning right.
- Mast-arm signals encourage higher speeds since drivers can see several in a row. If they are green, drivers are more likely to accelerate. But pole-mounted signals are only visible to drivers closer to the intersection, causing them to drive slower on the approach.

## PHASING

A signal phase is defined as the cycle length allocated to a traffic movement at an intersection receiving the right-of-way, or to any combination of traffic movements receiving the right of way simultaneously. The combination of all phases is equal to one cycle length.



### Basic Signal Timing

The “timing” is the time in seconds allocated to various vehicular and pedestrian movements. A traffic control signal transmits information to the users by selective illumination of different color lights at a signalized intersection. The illuminated color indicates the user should take a specific action at the signalized intersection:

- **Green phase.** Green phase is when motorists and bicyclists may proceed through the intersection.
- **Yellow phase.** Yellow phase is the cycle phase before changing to the red interval that prohibits traffic movement. It signifies to users the light is about to turn red and they should stop if they can safely do so, or continue proceeding if that is safer. A properly timed yellow time interval is important to reduce signal violations by users passing through the intersection.
- **All-red phase.** All-red phase is that portion of a traffic cycle time where all vehicles are prohibited from any movements at the intersection. The all-red time follows the yellow time interval and precedes the next green interval. The purpose of the all-red time is to allow vehicles that entered the intersection late during the yellow time to clear the intersection before the traffic signal displays green time for conflicting approaches.



*Permissive left-turn signal  
(Credit: Michele Weisbart)*

### Left-Turn Phasing

The most commonly used “left turn” phases at an intersection with a left-turn lane are

- **Permissive.** Under permissive left turn phasing, through traffic may proceed straight through the intersection with a circular green signal indication, as side traffic is stopped (with a circular red signal indication); the left turning vehicles are permitted to make the turn when they find a safe and adequate gap from the approaching vehicles. Permissive left turn phases create conflicts with pedestrians crossing the street as the timing puts the two on a collision course.
- **Protected-permissive.** Under protected-permissive left turn phasing, left turns are allowed to pass the intersection with a green arrow first during the protected phase (opposing through traffic is stopped); usually three to five vehicles are allowed in the cycle before the left turn is changed from a left arrow to a circular green indication, and opposing through traffic is allowed to pass through the intersection. During the permissive phase motorists may turn left while others go straight. Protected-



*Protected-permissive left-  
turn signal  
(Credit: Michele Weisbart)*



*Protected left-turn signal  
(Credit: Michele Weisbart)*



permissive left turn phases create conflicts with pedestrians crossing the street as the timing puts the two on a collision course, especially with left-turning drivers who arrived after the left-turn phase and are impatient to turn left before the signal reverts to red.

- **Protected only.** Under protected left turns, drivers can only turn left with a left-turn green arrow. The protected left turns can be either “leading” or “lagging.” A leading protected left turn allows left-turns during the beginning of the cycle. A lagging protected left allows left turns at the end, after opposing through traffic has proceeded. Protected left-turn phases are preferred to both permissive phases because they eliminate the inherent conflict between left turning vehicles and pedestrians. Protected left turns provide the greatest safety for pedestrians. Permissive phases are typically used to maintain a higher LOS for motorists.

### Pedestrian Phasing

Basic pedestrian signal timing principles should be combined with innovative pedestrian signal timing techniques to enhance pedestrian safety and convenience.

Pedestrian signal heads provide indications exclusively intended for controlling pedestrian traffic. These signal indications consist of the illuminated symbols of a WALKING PERSON (symbolizing WALK) and an UPRAISED HAND (symbolizing DON'T WALK). Pedestrian signal head indications have the following meanings:

- A steady WALKING PERSON (WALK) signal indication means that a pedestrian facing the signal indication is permitted to start to cross the roadway in the direction of the signal indication, possibly in conflict with turning vehicles.
- A flashing UPRAISED HAND (DON'T WALK) signal indication means that a pedestrian shall not start to cross the roadway in the direction of the signal indication, but that any pedestrian who has already started to cross shall proceed to the far side of the traveled way of the street or highway, unless otherwise directed by a traffic control device to proceed only to a median or pedestrian refuge area.
- A steady UPRAISED HAND (DON'T WALK) signal indication means that a pedestrian shall not enter the roadway in the direction of the signal indication.

The text below discusses the timing of each of these indicators.

#### **Walk Interval**

The WALK interval (clear WALKING PERSON) must typically be a minimum of 7 seconds. However, to provide more convenience for pedestrians, and possibly more safety due to better pedestrian behavior, the WALK interval should be maximized using the following techniques:



- Instead of providing the minimum WALK interval, maximize the WALK interval within the available green interval. This is accomplished by subtracting the necessary pedestrian clearance interval (discussed below) from the available green time for the concurrent vehicular movements.
- Except at intersections where pedestrians are relatively few, and anywhere that vehicle signals are set on fixed time, WALK intervals should be set on “recall” so that they are automatically provided during every signal cycle.
- Where a major street intersects a minor side street, the WALK interval for crossing the minor street can be set on recall, concurrent with the green interval for the parallel through vehicle movement, which is typically set to recall as well. This minimizes pedestrian delay along the major street with no impact to motor vehicle capacity.



*Walk signal  
(Credit: Sky Yim)*

### **Pedestrian Clearance Interval**

The procedures for calculating the timing of the pedestrian clearance interval (flashing orange hand) are included in the MUTCD, but have recently changed. The pedestrian clearance interval is calculated to allow a pedestrian who left the curb at the end of the WALK interval traveling at a walking speed of 3.5 feet per second to travel the length of the crosswalk. The crosswalk length should be measured from the center of one curb ramp to the center of the opposing curb ramp. This speed allows pedestrians, especially seniors, children, and ADA users, to clear the intersection. The MUTCD includes another test that requires the total of the WALK interval plus the pedestrian clearance interval to be sufficient to allow a pedestrian traveling at a walking speed of 3 feet per second to travel the length of the crosswalk, measured from the top of one ramp to the bottom of the opposing ramp. Any additional time that is required to satisfy this second requirement should be added to the walk interval. In neighborhoods where high numbers of slow pedestrians are present, such as near senior centers, rehabilitation centers, and



*Pedestrian countdown signals  
(Credit: Sky Yim)*



disabled centers, the interval should be set for even slower speeds.

The MUTCD also requires that countdown pedestrian signals be installed for all pedestrian signals where the pedestrian change interval is more than 7 seconds. These signals count down the pedestrian clearance interval and provide more information to pedestrians, allowing them to more easily adjust their walking patterns to ensure they are out of the crosswalk before the end of the pedestrian clearance interval. Research on pedestrian countdown signals has determined

- Pedestrians understand how they work.
- Fewer people start walking in the pedestrian clearance interval.
- Very few pedestrians are left in the crosswalk during the steady orange hand.
- Drivers don't accelerate to beat the light.
- Research in San Francisco shows a 25 percent reduction in all crashes.

### **Other Signal Design Changes for Pedestrians**

Where appropriate, use signal timing and operations techniques that minimize conflicts with pedestrians and motor vehicles, including the following:

- Protected only left-turn phases.
- Leading pedestrian intervals (LPI) where the pedestrian WALK interval is displayed 2 to 5 seconds prior to the concurrent green interval. This enables pedestrians to enter the crosswalk before drivers turn, increasing their visibility to drivers.
- Prohibiting right-turns-on-red where there are restricted sight lines between motorists and pedestrians, where there are an unusual number of pedestrian conflicts with turns on red compared to right-turns-on-green, or where a leading pedestrian interval is used.
- Signs that remind drivers to yield to pedestrians when turning at signals.
- Pedestrian-user-friendly-intelligent (PUFFIN) signals, which detect slower pedestrians in crosswalks and add clearance interval time to the pedestrian signal.
- Exclusive Pedestrian Phase, which stop traffic on all legs of the intersection and allow pedestrians to cross diagonally, may be used where turning vehicles conflict with very high pedestrian volumes. Although pedestrians can cross in any direction during the pedestrian phase, pedestrians typically have to wait for both vehicle phases before they get the walk signal again. Exclusive Pedestrian Phase intersections can incorporate a walk phase concurrent with the green phase for pedestrians continuing along a straight path to eliminate this delay.



## ROUNDBABOUTS

Modern roundabouts are low-speed, compact designs and are not the same as the old, fast, and dangerous high speed rotaries found in the Northeast or the old traffic circles such as Young Circle in Hollywood and DuPont Circle in Washington DC. Modern roundabouts are becoming more widely accepted in the United States. Modern roundabouts are potentially the cheapest, safest, and most aesthetic form of traffic control for many intersections. The Federal Highway Administration states that modern roundabouts reduce fatalities by approximately 90 percent. A roundabout is an intersection design with the following characteristics and features.



*Acacia Roundabout (Credit: Ken Sides)*

Users approach the intersection, slow down, yield and/or stop for pedestrians in a crosswalk, and then enter a circulating roadway, yielding to drivers already in the roundabout. The circulating roadway encircles a central island around which vehicles travel counterclockwise. Splitter islands force drivers to turn right, and provide a refuge for pedestrians. Horizontal deflection encourages slow traffic speeds, but allows movement by trucks. A landscaped visual obstruction in the central island obscures the driver's view of the road beyond, to discourage users from entering the roundabout at high speeds. The central island should not

include pedestrian attractions, such as benches, because it's not desirable for pedestrians to walk in or across the roundabout circulating lanes. The central island can vary in shape from a circle to a "square-a-bout" in historic areas, ellipses at odd shaped intersections, dumbbell, or even peanut shapes.

Each leg of a modern roundabout has a triangular splitter island that provides a refuge for pedestrians, prevents drivers from turning left (the "wrong-way"), guides drivers through the roundabout by directing them to the edge of the central island, and helps to slow drivers. Roundabouts can range from quite small to quite large, from a central island diameter of about 12 feet for a traffic calming device at a neighborhood intersection to 294 feet to the back of sidewalk on a large multi-lane roundabout.

Modern roundabouts should be designated to reduce the relative speeds between conflicting traffic streams.

This section of the chapter briefly describes roundabout application and design information. For more detailed information, refer to NCHRP Report 672, *Roundabouts: An Informational Guide*, Second Edition.



## ADVANTAGES AND DISADVANTAGES

Modern roundabouts reduce vehicle-to-vehicle and vehicle-to-pedestrian conflicts and, thanks to a substantial reduction in vehicle speeds, reduce all forms of crashes and crash severity. In particular, roundabouts eliminate the most lethal crashes : head on and T-bone collisions.

Other benefits of roundabouts include the following:

- Little to no delay for pedestrians, who have to cross only one direction of traffic at a time
- Improved accessibility to intersections for bicyclists through reduced conflicts and vehicle speeds
- A smaller carbon footprint (no electricity is required for operation and fuel consumption is reduced as motor vehicles spend less time idling and don't have to accelerate as often from a dead stop)
- They work well in South Florida, especially during hurricane season.
- The opportunity to reduce the number of vehicle lanes between intersections (e.g., to reduce a five-lane road to a two-lane road, due to increased vehicle capacity at intersections)
- Little to no stopping during periods of low flow
- Significantly reduced maintenance and operational costs because the only costs are related to the landscape
- Reduced delay, travel time, and vehicle queue lengths
- Lowered noise levels
- Less fuel consumption and air pollution
- Simplified intersections
- Facilitated U-turns
- The ability to create a gateway and/or a transition between distinct areas through landscaping
- When constructed as a part of a new road or the reconstruction of an existing road, the cost of a roundabout is minimal and can be cheaper than the construction of an intersection and the associated installation of traffic signals and additional turn lanes
- Light rail can pass through the center of a roundabout without delay because rail has the right of way

A possible disadvantage is that sight-impaired people can have difficulty navigating around large roundabouts. But this can be mitigated with ground level wayfinding devices.

Roundabouts are not always the most appropriate solution, it requires location specific analysis. Also roundabouts may not be the best solution near active railroad crossings.



## GENERAL DESIGN ELEMENTS OF ROUNDABOUTS

### Central Island

The design of the central island is an important element of a roundabout. In conjunction with well-designed approach and departure lanes, the central island controls vehicle speeds through deflection and controls the size of vehicles that can pass through and turn at a roundabout. It provides space for landscaping to beautify an intersection or create a focal point or community enhancement, but it also provides space for the inclusion of an uprighted vertical element such as a tree, which is important in providing long range conspicuity of a roundabout.

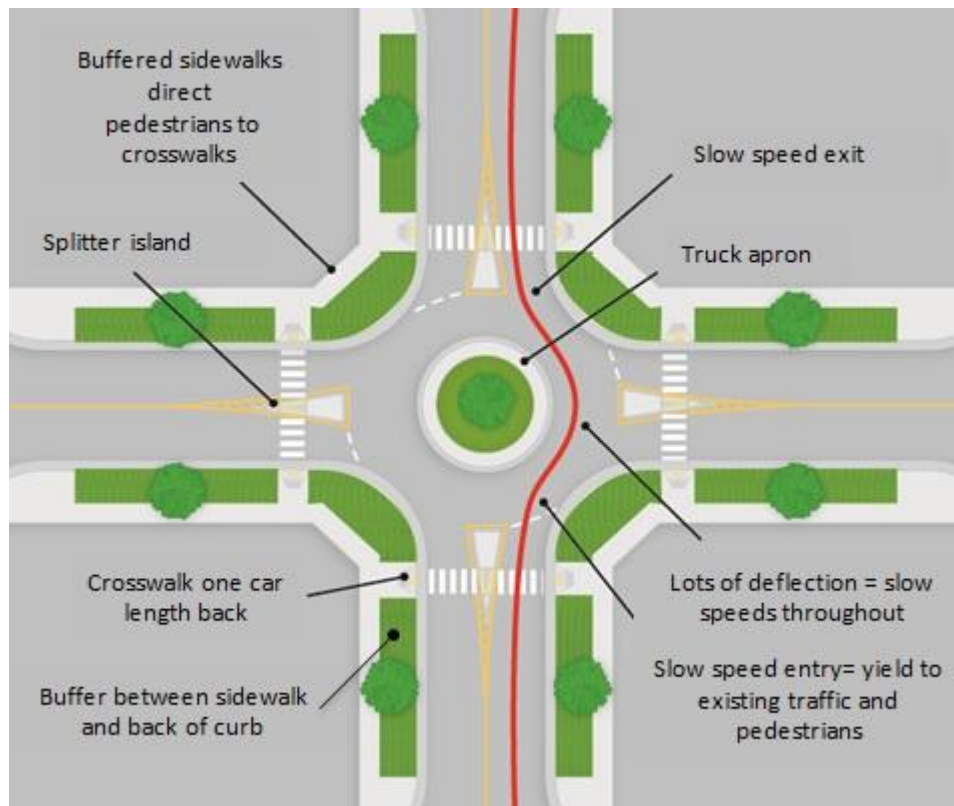

*Single-lane roundabout  
(Credit: Michele Weisbart)*

### Splitter Islands

Splitter islands and/or medians on each approach serve several functions. They provide a refuge for pedestrians crossing at the roundabout, breaking the crossing into two smaller crossings. This allows pedestrians to select smaller gaps and cross more quickly. Splitter islands and medians direct vehicles into the circulating lane and limit the ability of drivers to make left turns the wrong way into the circulating roadway. Splitter islands should have a minimum width



of 6 feet, and preferably 8 feet, from the face-of-curb to the opposite face-of-curb. This width provides a comfortable, safe refuge for groups of pedestrians and pedestrians with bicycles.

### Truck Apron

Because central islands must be made large enough to deflect and hence control the speed of passenger vehicles, they can limit the ability of trucks to pass through or turn at a roundabout. To accommodate large vehicles, a truck apron (a paved, load-bearing area) is included around the perimeter of the central island. The truck apron is often paved with a fairly rough texture, and raised enough to discourage encroachment by smaller high-speed passenger cars. The outer curb of the truck apron creates a distinction between the truck apron and the circulating lane, usually by means of unusual contrast and a maintainable curb as high as three inches.

### Pedestrian Crossings

Pedestrian crossings are located one or more car lengths back from the circulating roadway to shorten the crossing distance and separate vehicle-to-pedestrian conflicts from vehicle-to-vehicle conflicts, so pedestrians don't cross in front of drivers looking left.

### Signing and Marking

Signing and marking should be in compliance with the current version of the MUTCD. For detailed design guidance on roundabouts, refer to the NCHRP Report 672, *Roundabouts: An Informational Guide*, Second Edition, 2010. However, care must be taken to not oversign roundabouts by including every sign allowed at roundabouts, except for needed directional signs; most roundabouts are designed so their function and use are self-explanatory.

## ROUNDBABOUT DESIGN CRITERIA

Before starting the design of a roundabout it is very important to determine the following:

- The number and type of lane(s) on each approach and departure as determined by a capacity analysis
- The design vehicle for each movement
- The presence of on-street bike lanes
- The goal/reason for the roundabout, such as crash reduction, capacity improvement, speed control, or creation of a gateway or a focal point
- Right-of-way and its availability for acquisition if needed
- The existence or lack of sidewalks
- Effects on pedestrian route directness
- The approach grade of each approach
- Transit, existing or proposed



## OPERATIONS AND ANALYSIS

Roundabouts operate on the principle that drivers approach a roundabout and look left for any circulating vehicles that could conflict with their travel path. If there is no possible conflict, the approaching driver can enter the roundabout without delay. If there is a vehicle, or many conflicting vehicles, the approaching drivers stop and yield to the conflicting vehicle(s) on their left and wait for a safe gap to enter the roundabout.

In simple terms, a roundabout capacity analysis determines the number of vehicles seeking to enter a roundabout from each approach and the availability of gaps. Based on this gap acceptance analysis, the number and type of approach and departure lanes can be determined to provide the desired level of operation. Since roundabouts keep traffic moving they have greater capacity than both signalized and stop-controlled intersections. Roundabout designer Michael Wallwork has observed about a 30 percent increase in intersection capacity with roundabouts over traffic signals.

## SINGLE-LANE ROUNDABOUTS

Single-lane roundabouts can vary in size with central island diameters from 12 to 90 feet to fit a wide range of intersections and accommodate through movements and different turn movements by various design vehicles. As such, they can be used at a large number of intersections to achieve various objectives.

In some cases, roundabouts are constructed to accommodate through movements by large articulated trucks but do not permit them to make turn movements. However, they do accommodate turn movements by single unit trucks such as ladder trucks and garbage trucks. In some cases, restricting or not accommodating turn movements by articulated trucks enables the construction of a smaller roundabout without acquisition of right-of-way and with all the benefits of roundabouts at the cost of forcing the occasional large truck to take an alternate route.

### Design

Following a careful assessment of the need to accommodate some or all design vehicle movements and the impact of that accommodation, the size of the roundabout is selected and a concept plan is prepared. The concept plan is then refined with the simultaneous application of design vehicle templates and design speed checks until a suitable design is prepared that meets design requirements. Pedestrian and bike facilities are as applicable and the overall design is refined with the signing and marking, along with construction details. In some cases, right turn lanes can be added to accommodate specific high right turn volumes.



## MULTI-LANE ROUNDABOUTS

When single-lane roundabouts prove to be inadequate for the traffic volume, consideration should be given to using roundabouts that have two through lanes on the major street and a single lane on the minor street with or without additional turn lanes before automatically designing a full multilane roundabout. Because these roundabouts are larger than single-lane roundabouts, they often accommodate all turn movements by most large vehicles. However, it is still necessary to confirm the size and movements by the design vehicle(s) because these roundabouts often have to accommodate larger trucks or special vehicles.

With many old style freeway interchanges failing, often because of a lack of storage for turning vehicles, retrofitting a roundabout on both sides of the freeway can reduce congestion and improve pedestrian mobility without widening the freeway bridge. Sometimes, the retrofit of a standard interchange with roundabouts can reduce the space allocated to the interchange, freeing the land for other community uses.

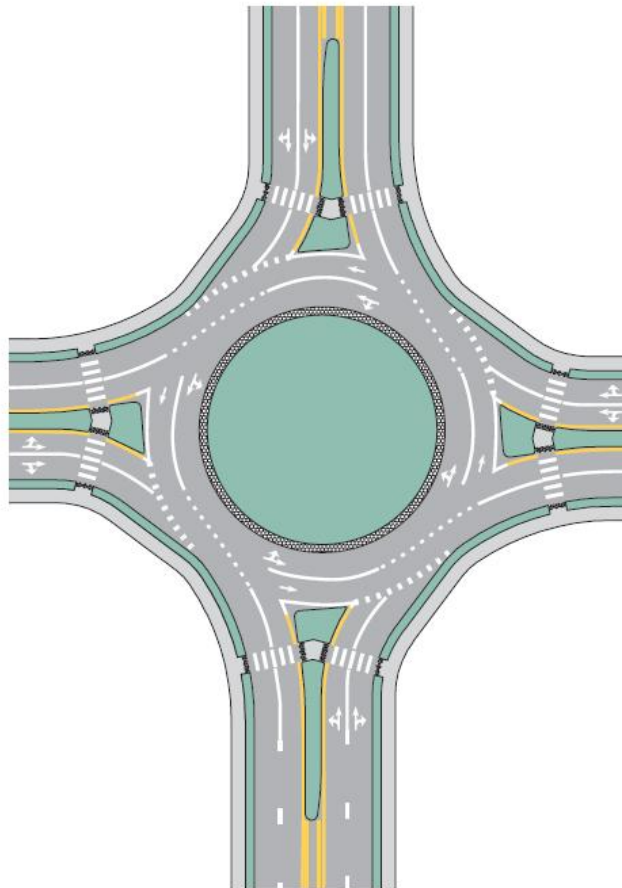

*Multi-lane roundabout*

*(Source: 2009 Manual on Uniform Traffic Control Devices, Figure 3C-6)*



### Accessibility

Multi-lane roundabouts are more complex than one lane roundabouts for pedestrians and bicyclists to use because of the additional lanes, slightly higher speeds, and longer crossing distances. Crossing by some pedestrians with disabilities is a more complex task. As a consequence, the current draft (Proposed Right-of-Way Accessibility Guidelines) PROWAG includes a requirement to install accessible pedestrian signals at all crosswalks across any roundabout approach with two or more lanes in one direction. The PROWAG requirement does not specify the type of signal except that it must be accessible, including a locator tone at the pushbutton, with audible and vibrotactile indications of the pedestrian walk interval.

### Metering signals

Often a roundabout capacity is only exceeded during one peak period and often for only a short period. Rather than constructing a larger multi-lane roundabout, consideration should be given to constructing a smaller roundabout that is adequate for 23 hours a day and adding a metering signal for the short peak period when congestion can occur. A metering signal is similar to ramp metering where the approaching vehicle queue is metered and a part time signal is used to stop the conflicting vehicle flow to allow the congested approach to enter the roundabout. The result is a smaller, slower roundabout that is more appropriate for all users for most of the day.

### Design

Multi-lane roundabouts are more complex to design. However, the design process is the same as for single-lane roundabouts: confirm the design vehicle for each movement, prepare a concept plan, and refine it with the simultaneous use of design vehicle templates or software like AutoTURN and speed curves.

## MINI-ROUNDBABOUTS

Mini-roundabouts are a new form of roundabout that includes a traversable central island and traversable splitter islands to accommodate large vehicles.

### Appropriate Applications

Mini-roundabouts are used in low-speed urban environments, where operating speeds are 30 mph or less, and right-of-way constraints preclude the use of a standard roundabout. The design is based on passenger vehicles passing through the roundabout without travelling over the central island, whereas large vehicles will turn over the central island and in some cases, the splitter islands.



### Design

The design of mini-roundabouts is similar to other roundabouts in that the design vehicle for each movement must be determined following a capacity analysis. The design is undertaken using the same combination of design vehicle templates and speed curves.

#### NEIGHBORHOOD TRAFFIC CIRCLES



Neighborhood traffic circles are very small circles that are retrofitted into local street intersections to control vehicle speeds within a neighborhood. Typically, a tree and/or landscaping are located within the central island to provide increased visibility of the roundabout and enhance the intersection. Neighborhood traffic circles should generally have similar features as roundabouts, including yield-on-entry and painted or mountable splitter islands.

*Neighborhood traffic circle  
(Credit: Kimley-Horn and Associates, Inc.)*

Neighborhood traffic circles should be used on low-volume, neighborhood streets. In these environments, larger vehicles can turn left in front of the central island.

### Design

The design of neighborhood traffic circles is primarily confined to selecting a central island size to achieve the appropriate design speed of around 15 mph. See Chapter 11, “Traffic Calming,” for more information.



This page left blank intentionally.



## 7. UNIVERSAL PEDESTRIAN ACCESS

INTRODUCTION.....	1
ESSENTIAL PRINCIPLES OF UNIVERSAL PEDESTRIAN ACCESS.....	2
LEGAL FRAMEWORK.....	2
USERS AND NEEDS .....	4
People with Mobility Impairments .....	4
People with Visual Impairments .....	5
People with Cognitive Impairments.....	6
Children and Older Adults .....	6
PEDESTRIAN FACILITY DESIGN .....	7
Sidewalks .....	7
Curb Ramps.....	9
Detectable Warnings.....	13
Signals.....	14
LAND USE AND SIDEWALK DESIGN GUIDELINES .....	15
Low / Medium Density Residential .....	16
Medium / High Density Residential .....	17
Neighborhood Commercial .....	17
General / Regional Commercial .....	18
Mixed / Multi-Use .....	18
Industrial.....	19
Downtown Core/Main Street .....	19
Office Park.....	20
Public Facilities .....	20
DESIGN SPECIFICATIONS BY ROADWAY TYPE AND LAND USE .....	21
General Guidelines .....	23
FOR MORE INFORMATION .....	23



*Credit: Kimley-Horn and Associates, Inc.*



## INTRODUCTION

Nowhere is the concept of universal access more important than in the design of the pedestrian environment. While perhaps not intuitively obvious at first glance, this is the realm of streets with the greatest variation in user capabilities, and thus the realm where attention to design detail is essential to effectively balance user needs. This is also the realm where signs and street furniture are located, and where transitions are made between modes (e.g., driver or passenger to pedestrian via parking, bus stop/train station, or bike rack). The pedestrian environment includes sidewalks, curb ramps, crosswalks, bus stops, signs, and street furniture.

Without design guidelines, sidewalks are often too narrow, utility poles obstruct travel, steep driveway ramps are impassable to wheelchair users, and bus stops become blocked by the disorderly placement of shelters, poles, trash receptacles, and bike racks.



*Sidewalks constructed without adequate design guidelines (Credit: Kimley-Horn and Associates, Inc.)*



With well-defined guidelines, sidewalks are built to accommodate pedestrians of all ages and physical abilities, and become inviting pedestrian environments as the adjacent picture shows.

Designing the pedestrian realm for universal access enables persons with disabilities to live independently and lead full, enriched lives; they are able to go to work and to school, to shop, and otherwise engage in normal activities. Moreover, walking environments that accommodate people with disabilities improve walking conditions for everyone. People with strollers and rolling suitcases can make their way about with ease. Children can mature by learning to navigate through their neighborhoods with independence. Inaccessible pedestrian networks, on the other hand, can lead to people becoming housebound and socially isolated, which in turn can lead to a decline in well-being and a host of associated negative health outcomes such as depression.



*Wheelchair users need accessible sidewalks  
(Credit: Dan Burden)*

This chapter describes the legal framework for accessible design of streets and sidewalks, various users of streets and sidewalks and their needs, and important elements of pedestrian facility design. The chapter ends with sidewalk design guidelines for a number of street classifications.

## ESSENTIAL PRINCIPLES OF UNIVERSAL PEDESTRIAN ACCESS

The following design principles inform the recommendations made in this chapter and should be incorporated into every pedestrian improvement:

- The walking environment should be safe, inviting, and accessible to people of all ages and physical abilities.
- The walking environment should be easy to use and understand.
- The walking environment should seamlessly connect people to places. It should be continuous, with complete sidewalks, well-designed curb ramps, and well-designed street crossings

## LEGAL FRAMEWORK

Under Title II of the Americans with Disabilities Act (ADA) of 1990, state and local governments and public transit authorities must ensure that all of their programs, services, and activities are



accessible to and usable by individuals with disabilities. They must ensure that new construction and altered facilities are designed and constructed to be accessible to persons with disabilities. State and local governments must also keep the accessible features of facilities in operable working condition through maintenance measures including sidewalk repair, landscape trimming, work zone accessibility, and snow removal.

Under the ADA, the U.S. Access Board is responsible for developing the minimum accessibility guidelines needed to measure compliance with ADA obligations when new construction and alterations projects are planned and engineered. These guidelines for public rights-of-way are found in draft form in the Public Rights-of-Way Accessibility Guidelines (draft PROWAG). The U.S. Department of Transportation has recognized this document as current best practices in pedestrian design and has indicated its intent to adopt the final PROWAG.



*Obstructions can make passage difficult or impossible for wheelchair users. (Credit: Michael Ronkin)*

In addition to the PROWAG guidelines, Title II of the ADA also requires states and localities to develop ADA Transition Plans that remove barriers to disabled travel.

These plans must

- Inventory physical obstacles and their location
- Provide adequate opportunity for residents with disabilities to provide input into the Transition Plan
- Describe in detail the methods the entity will use to make the facilities accessible
- Provide a yearly schedule for making modifications
- Name an official/position responsible for implementing the Transition Plan
- Set aside a budget to implement the Transition Plan



*Missing curb cut ramp at crosswalk  
(Credit: Kimley-Horn and Associates, Inc.)*



ADA Transition Plans are intended to ensure that existing inaccessible facilities are not neglected indefinitely and that the community has a detailed plan in place to provide a continuous pedestrian environment for all residents.

## USERS AND NEEDS

To fully accommodate everybody, designers must consider the widely varying needs and capabilities of the people in the community. People walk at different speeds. Some are able to endure long treks, while others can only go short distances. Some use wheelchairs and are particularly sensitive to uneven pavement and surface materials. Others have limited sight and rely on a cane. People's strengths, sizes, and judgmental capabilities differ significantly. The needs of one group of users may be at odds with those of another group of users. For instance, gradual ramps and smooth transitions to the street help people in wheelchairs, but present challenges for the sight-impaired when they can't easily find the end of the sidewalk and beginning of the street.

***“Not friendly to the disabled. There are a few talking or beeping street lights but they break frequently and the street crossings are made for the driver's wellbeing, not the person walking.”***

*- Broward Complete Streets survey respondent*

The text below identifies the unique constraints individuals with different types of disabilities and limitations face as pedestrians. Understanding their needs will help ensure more universal design of the sidewalk network.

### PEOPLE WITH MOBILITY IMPAIRMENTS

People with mobility impairments range from those who use assistive devices, such as wheelchairs, crutches, canes, orthotics, and prosthetic devices, to those who use no such devices but face constraints walking long distances on non-level surfaces or on steep grades.

Wheelchair and scooter users are most affected by the following:

- Uneven surfaces that hinder movement
- Rough surfaces that make rolling difficult and can cause pain, especially for people with back injuries
- Steep uphill slopes that slow the user
- Steep downhill slopes that cause a loss of control



*Steep cross slopes create difficulties for wheelchair users.*

*(Credit: Michael Ronkin)*



- Cross slopes that make the assistive device unstable
- Narrow sidewalks that impede the ability of users to turn or to cross paths with others
- Devices that are hard to reach, such as push buttons for walk signals and doors
- The lack of time to cross the street

Walking-aid users are most affected by the following:

- Steep uphill slopes that make movement slow or impossible
- Steep downhill slopes that are difficult to negotiate
- Cross slopes that cause the walker to lose stability
- Uneven surfaces that cause these users to trip or lose balance
- Long distances
- Situations that require fast reaction time
- The lack of time to cross the street



*Walking-aid users need clear sidewalks.  
(Credit: Dan Burden)*

Prosthesis users often move slowly and have difficulty with steep grades or cross slopes.

#### PEOPLE WITH VISUAL IMPAIRMENTS

People with visual impairments include those who are partially or fully blind, as well as those who are colorblind. Visually impaired people face the following difficulties:

- Limited or no visual perception of the path ahead
- Limited or no visual information about their surroundings, especially in a new place
- Changing environments where they rely on memory
- Lack of non-visual information
- Inability to react quickly
- Unpredictable situations, such as complex intersections that are not at 90 degrees
- Inability to distinguish the edge of the sidewalk from the street
- Compromised ability to detect the proper time to cross a street
- Compromised ability to cross a street along the correct path
- Need for more time to cross the street

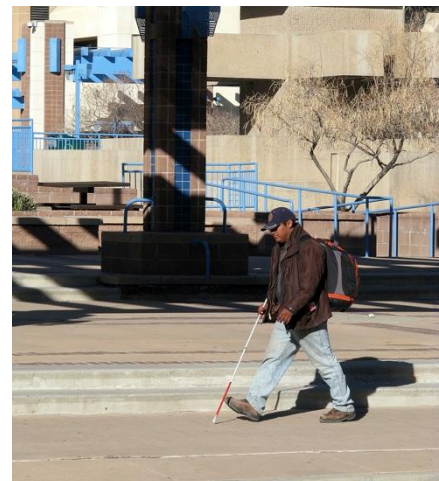

*Sight-impaired pedestrians need additional sensory cues.  
(Credit: Dan Burden)*



## PEOPLE WITH COGNITIVE IMPAIRMENTS

People with cognitive impairments encounter difficulties in thinking, learning, and responding, and in performing coordinated motor skills. Cognitive disabilities can cause some to become lost or have difficulty finding their way. They may also not understand standard street signs and traffic signals. Some may not be able to read and benefit from signs with symbols and colors.

## CHILDREN AND OLDER ADULTS

Children and many older adults don't fall under specific categories for disabilities, but must be taken into account in pedestrian planning. Children are less mentally and physically developed than adults and have the following characteristics:

- Less peripheral vision
- Limited ability to judge speed and distance
- Difficulty locating sounds
- Limited or no reading ability so don't understand text signs
- Occasional impulsive or unpredictable behavior
- Little familiarity with traffic
- Difficulty in carrying packages

Small children are also more difficult to see than adults.

The natural aging process generally results in at least some decline in sensory and physical capability. As a result, many older adults experience the following:

- Declining vision, especially at night
- Decreased ability to hear sounds and detect where they come from
- Less strength to walk up hills and less endurance overall
- Reduced balance, especially on uneven or sloped sidewalks
- Slowed reaction times to dangerous situations
- Slowed walking speed
- Increased fragility and frailty: their bodies are more likely to be seriously injured in a fall or vehicular crash and their recovery becomes longer and more tenuous. This makes older pedestrians the most vulnerable pedestrians.



*Vulnerable users crossing street  
(Credit: Dan Burden)*



## PEDESTRIAN FACILITY DESIGN

To provide a seamless path of travel throughout the community that is accessible to all, designers should consider five important elements: sidewalks, curb ramps, crosswalks, signals, and bus stops.

### SIDEWALKS

Sidewalks should provide a comfortable space for pedestrians between the roadway and adjacent land uses. Sidewalks along city streets are the most important component of pedestrian mobility. They provide access to destinations and critical connections between modes of travel, including automobiles, transit, and bicycles. General provisions for sidewalks include pathway width, slope, space for street furniture, utilities, trees and landscaping, and building ingress/egress.

Sidewalks include four distinct zones: the frontage zone, the pedestrian (aka walking) zone, the furniture zone, and the curb zone. The minimum widths of each of these zones vary based on street classifications as well as land uses. The Street Classifications section in this chapter describes these recommendations in more detail as applied to individual local jurisdictions. The table at the end of this chapter recommends minimum widths for each zone for different street types and land uses.

#### Frontage Zone

The frontage zone is the portion of the sidewalk located immediately adjacent to buildings, and provides shy distance from buildings, walls, fences, or property lines. It includes space for building-related features such as entryways and accessible ramps. It can include landscaping as well as awnings, signs, news racks, benches, and outdoor café seating. In single family residential neighborhoods, landscaping typically occupies the frontage zone.

#### Pedestrian Zone

The pedestrian zone, situated between the frontage zone and the furniture zone, is the area dedicated to walking and should be kept clear of all fixtures and obstructions. Within the pedestrian zone, the Pedestrian Access Route (PAR) is the path that provides continuous connections from the public right-of-way to building and property entry points, parking areas, and public transportation. This pathway is required to comply with ADA guidelines and is intended to be a seamless pathway for wheelchair and white cane users. As such, this route should be firm, stable, and slip-resistant, and should comply with maximum cross slope requirements (2 percent grade). The walkway grade shall not exceed the general grade of the adjacent street. Aesthetic textured pavement materials (e.g., brick and pavers) are best used in the frontage and furniture zones, rather than the PAR. The PAR should be a minimum of 4 feet, but preferably at least 5 feet in width to provide adequate space for two pedestrians to



comfortably pass or walk side by side. All transitions (e.g., from street to ramp or ramp to landing) must be flush and free of changes in level. The engineer should determine the pedestrian zone width to accommodate the projected volume of users. In no case will this zone be less than the width of the PAR.

Non-compliant driveways often present significant obstacles to wheelchair users. The cross slope on these driveways is often much steeper than the 2 percent maximum grade. Driveway aprons that extend into the pedestrian zone can render a sidewalk impassable to users of wheelchairs, walkers, and crutches. They need a flat plane on which to rest all four supports (two in the case of crutches). To provide a continuous PAR across driveways, aprons should be confined to the furniture and curb zones.

### Furniture Zone

The furniture zone is located between the curb line and the pedestrian zone. The furniture zone should contain all fixtures, such as street trees, bus stops and shelters, parking meters, utility poles and boxes, lamp posts, signs, bike racks, news racks, benches, waste receptacles, drinking fountains, and other street furniture to keep the pedestrian zone free of obstructions. In residential neighborhoods, the furniture zone is often landscaped. Resting areas with benches and space for wheelchairs should be provided in high volume pedestrian districts and along blocks with a steep grade to provide a place to rest for older adults, wheelchair users, and others who need to catch their breath.

### Curb Zone

The curb zone serves primarily to prevent water and cars from encroaching on the sidewalk. It defines where the area for pedestrians begins, and the area for cars ends. It is the area people using assistive devices must traverse to get from the street to the sidewalk, so its design is critical to accessibility.

### Other Sidewalk Guidelines

- Landscaped buffers or fences should separate sidewalks from off-street parking lots or off-street passenger loading areas.
- Pedestrian and driver sight distances should be maintained near driveways. Fencing and foliage near the intersection of sidewalks and driveways should ensure adequate sight distance as vehicles enter or exit.
- Where no frontage zone exists, driveway ramps usually violate cross slope requirements. In these situations, sidewalks should be built back from the curb at the driveway as shown in the adjacent photo.



*Routing sidewalks around driveway ramps maintains a flush surface. (Credit: Dan Burden)*



## CURB RAMPS

Proper curb ramp design is essential to enable pedestrians using assistive mobility devices (e.g., scooters, walkers, and crutches) to transition between the street and the sidewalk. These design guidelines provide a basic overview of curb ramp design. The ADA requires installation of curb ramps in new sidewalks and whenever an alteration is made to an existing sidewalk or street. Roadway resurfacing is considered an alteration and triggers the requirement for curb ramp installations or retrofits to current standards. Curb ramps are typically installed at intersections, mid-block crossings (including trail connections), accessible on-street parking, and passenger loading zones and bus stops.

The following define the curb ramp components along with minimum dimensions:

- Landing** – the level area at the top of a curb ramp facing the ramp path. Landings allow wheelchairs to enter and exit a curb ramp, as well as travel along the sidewalk without tipping or tilting. This landing must be the width of the ramp and measure at least 4 feet by 4 feet. There should also be a level (not exceeding a 2 percent grade) 4 foot by 4 foot bottom landing of clear space outside of vehicle travel lanes.
- Approach** – the portion of the sidewalk on either side of the landing. Approaches provide space for wheelchairs to prepare to enter landings.
- Flare** – the transition between the curb and sidewalk. Flares provide a sloped transition (10 percent maximum slope) between the sidewalk and curb ramp to help prevent pedestrians from tripping over an abrupt change in level. Flares can be replaced with curb where the furniture zone is landscaped.
- Ramp** – the sloped transition between the sidewalk and street where the grade is constant and cross slope at a minimum. Curb ramps are the main pathway between the sidewalk and street.

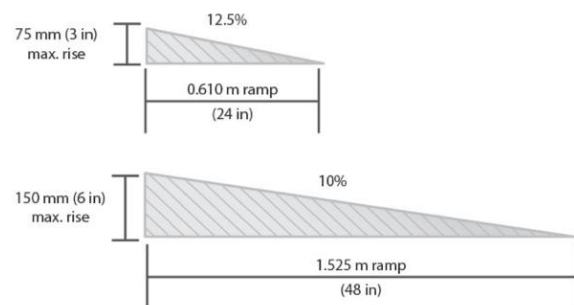
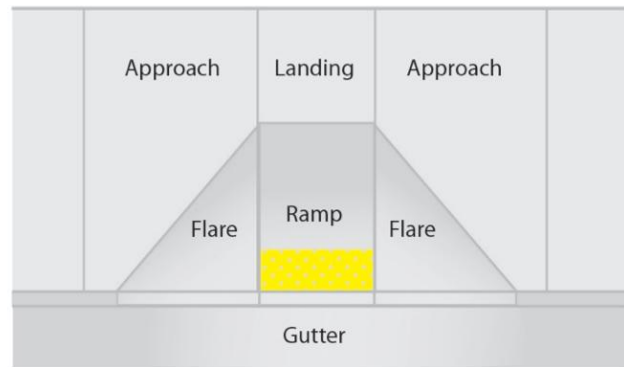

*Curb ramp components, and alternate ramp slopes (Credit: Michele Weisbart)*



- **Gutter** – the trough that runs between the curb or curb ramp and the street. The slope parallel to the curb should not exceed 2 percent at the curb ramp.
- **Detectable Warning** – surface with distinct raised areas to alert pedestrians with visual impairments of the sidewalk-to-street transition.

There are several different types of curb ramps. Selection should be based on local conditions. The most common types are diagonal, perpendicular, parallel, and blended transition. PROWAG provides additional design guidance and curb ramp examples appropriate for a variety of contextual constraints.

### Diagonal Curb Ramps

Diagonal curb ramps are single curb ramps at the apex of the corner. These have been commonly installed by many jurisdictions to address the requirements of the ADA, but have since been identified as a non-preferred design type as they introduce dangers to wheelchair users. Diagonal curb ramps send wheelchair users and people with strollers or carts toward the middle of the intersection and make the trip across longer.

### Perpendicular Curb Ramps

Perpendicular curb ramps are placed at a 90-degree angle to the curb. They must include a level landing at the top to allow wheelchair users to turn 90 degrees to access the ramp, or to bypass the ramp if they are proceeding straight. Perpendicular ramps work best where there is a wide sidewalk, curb extension, or planter strip. Perpendicular curb ramps provide a direct, short trip across the intersection.

### Parallel Curb Ramps

Parallel curb ramps are oriented parallel to the street; the sidewalk itself ramps down. They are used on narrow sidewalks where there isn't enough room to install perpendicular ramps. Parallel curb ramps require pedestrians who are continuing along the sidewalk to ramp down and up. Where space exists in a planting strip, parallel curb ramps can be designed in combination with perpendicular ramps to reduce the ramping for through pedestrians. Careful attention must be paid to the construction of the bottom landing to limit accumulation of water and/or debris.

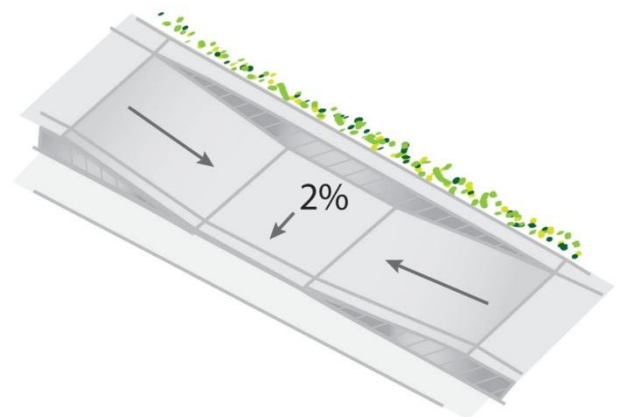

*Parallel curb ramp  
(Credit: Michele Weisbart)*



### Curb Ramp Placement

For best practices in ramp placement, refer to Chapter 6, “Intersection Design.”

One ramp should be provided for each crosswalk, which usually translates to 2 per corner. This maximizes access by placing ramps in line with the sidewalk and crosswalk, and by reducing the distance required to cross the street, compared with a single ramp on the apex.

A single ramp at the apex requires users to take a longer, more circuitous travel path to the other side and causes users to travel towards the center of the intersection where they may be in danger of getting hit by turning cars; being in the intersection longer exposes the user to greater risk of being hit by vehicles. A single ramp at the apex should be avoided in new construction and may be used only for alterations where a design exception is granted because of existing utilities and other significant barriers. In all cases, reducing the curb radius makes ramp placement easier.

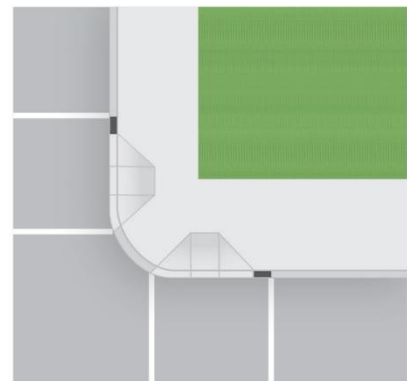

### Blended Transitions

Blended transitions are situations where either the entire sidewalk has been brought down to the street or crosswalk level, or the street has been brought up to the sidewalk level. They work well on large radius corners where it is difficult to line up the crosswalks with the curb ramps, but have drawbacks. Children, persons with cognitive impairments, and guide dogs may not distinguish the street edge. Turning vehicles may also encroach onto the sidewalk. For these reasons, bollards, planting boxes, or other intermittent barriers should be installed to prevent cars from traveling on the sidewalk. Detectable warnings should also be placed at the edge of the sidewalk to alert pedestrians with visual impairments of the transition to the street. Municipalities should follow the standards and guidelines for curb ramps provided in Table 7.1.

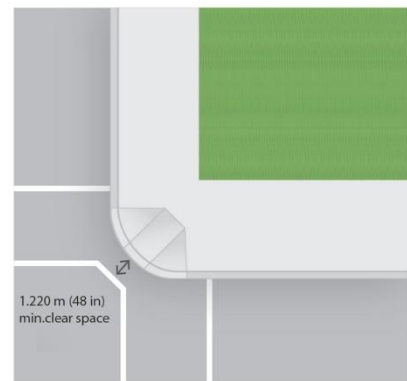

*One ramp per crosswalk vs. single ramp at the apex  
 (Credit: Michele Weisbart)*



**Table 7.1 Curb Ramp Design Standards and Guidelines**

Curb Ramp Type	Characteristic	ADA Standards	PROWAG
Perpendicular	Maximum slope of ramps	8.33%	8.3%
	Maximum cross-slope of ramps	2%	2%
	Maximum slope of flared sides	10%	10%
	Minimum ramp width	36"	48"
	Minimum landing length	36"	48"
	Minimum landing width		48"
	Maximum gutter slope	5%	5%
	Changes in level	Flush	Flush
	Truncated domes	Full depth and width	24" min.
Diagonal (at apex)	Maximum slope of ramps	8.33%	Not allowed except in alterations
	Maximum cross-slope of ramps	2%	2%
	Maximum slope of flared sides	10%	2%
	Minimum ramp width	36"	48"
	Minimum landing length	36	48"
	Minimum landing width		48"
	Maximum gutter slope	5%	2%
	Changes in level	Flush	Flush
	Minimum clear space		48"
Parallel and combination	Maximum slope of ramps	8.33%	8.3%
	Maximum cross-slope of ramps	2%	2%
	Maximum slope of flared sides	10%	
	Minimum ramp width	36"	48"
	Minimum landing length	36"	
	Minimum landing width		48"
	Maximum landing slope		2%
	Maximum gutter slope	5%	5%
	Changes in level	Flush	Flush
Truncated domes	Full depth and width	24"	
Curb extensions and built-up	Maximum slope of ramps	8.33%	8.3%
	Maximum cross-slope of ramps	2%	2%
	Maximum slope of flared sides	10%	10%
	Minimum ramp width	36"	48"
	Minimum landing length	36"	48"
	Minimum landing width		48"
	Maximum gutter slope	5%	5%
	Changes in level	Flush	flush
	Detectable warnings	Full depth and width	24"



## DETECTABLE WARNINGS

Because a curb ramp removes the curb that visually impaired persons use to identify the location of a street, a detectable warning surface must be placed at the back of the curb. This detectable strip should be as wide as the ramp and a minimum of 24 inches deep. One corner should be located at the back of the curb and the other corner may be up to 5 feet from the back of the curb. These strips are most effective when adjacent to smooth pavement so the difference is easily detected. Color contrast is needed so partially sighted people can see them.



*Required truncated domes  
(Credit: Ryan Snyder)*

The ADAAG standards for detectable warnings are as follows.

- General: Detectable warnings shall consist of a surface of truncated domes and shall meet standards for size, spacing, contrast and edges
- Base diameter: 0.9 inches minimum; 1.4 inches maximum
- Top diameter: 50 percent of base diameter minimum to 65 percent maximum
- Height: 0.2 inches
- Center-to-center spacing: 1.6 inches minimum to 2.4 inches maximum
- Base-to-base spacing: 0.65 inches minimum
- Visual contrast: light on dark, or dark on light with adjacent walking surface
- Platform edges: 24 inches wide and shall extend the full public use area of the platform

PROWAG best practices include the following.

- Width: as wide as the ramp and 24 inches deep
- Location: one corner at back of the curb, the other corner up to 5 feet from back of curb
- Used at
  - The edge of depressed corners
  - The border of raised crosswalks and intersections
  - The base of curb ramps
  - The border of medians
  - The edge of transit platforms and where railroad tracks cross the sidewalk



## SIGNALS

Signalized street crossings require special consideration of people with disabilities. The following text provides guidance to do that.

### Crossing Times

In planning for people with disabilities, slower speeds must be considered. This is critical in setting the timing of the walk phase of signalized intersections. The Manual on Uniform Traffic Control Devices (MUTCD) requires that transportation agencies use an assumed walking speed of 3.5 feet/second for signal timing. In situations where a large number of older adults or persons with disabilities cross, this may be inadequate to meet their needs. Some local signal maintaining agencies instead use 2.8 feet/second.

Local jurisdictions may also use PUFFIN (Pedestrian-User-Friendly-Intelligent) traffic signals to ensure that all pedestrians have adequate time to cross. PUFFIN crossings use infrared monitors to detect the presence of pedestrians in the crosswalk, and will hold the signal red for cross traffic until the pedestrian has left the crosswalk. PUFFIN crossings help slower pedestrians, but also help the flow of traffic because they allow the normal pedestrian design speed to be set at a higher level.

### Pedestrian-Activated Push Buttons

Pedestrian-activated traffic controls require pedestrians to push a button to activate a walk signal. As noted in Chapter 8, “Pedestrian Crossings,” pedestrian-activated signals are generally discouraged. The “WALK” signal should automatically activate except under circumstances described in that chapter. Where pedestrian-activated traffic controls exist, they should be located as close as possible to curb ramps without reducing the width of the path. The buttons should be at a level that is easily reached by people in wheelchairs near the top of the ramp. The U.S. Access Board guidelines recommend buttons raised above or flush with their housing and large enough (a minimum of 2 inches) for people with visual impairments to see them. The buttons should also be easy to push.



*Pedestrian push button placement (Credit: Michele Weisbart)*

### Accessible Pedestrian Signals (APS)

Wayfinding for pedestrians with visual impairments is significantly improved with the use of APS at signalized intersections. In fact, APS are the most commonly requested accommodation



under Section 504 of the Rehabilitation Act of 1973. APS communicate information about pedestrian timing in non-visual formats such as audible tones, verbal messages, and/or vibrating surfaces. Verbal messages provide the most informative guidance. These devices should be installed close to the departure location and on the side away from the center of the intersection. Since they are typically only audible 6 to 12 feet from the push button, 10 feet should separate two APS devices on a corner. If two accessible pedestrian pushbuttons are placed less than 10 feet apart or on the same pole, each accessible pedestrian pushbutton shall be provided with a pushbutton locator tone, a tactile arrow, a speech walk message for the WALKING PERSON (symbolizing WALK) indication, and a speech pushbutton information message. Volumes of the walk indication and push button locator tone shall automatically adjust in response to ambient sound.

## **LAND USE AND SIDEWALK DESIGN GUIDELINES**

The sidewalk design guidelines in this chapter integrate design and land use to provide safe and convenient passage for pedestrians. Sidewalks should have adequate walking areas and provide comfortable buffers between pedestrians and traffic. These guidelines will ensure sidewalks in all development and redevelopment projects provide access for people of all ages and physical abilities.

Sidewalks will vary according to the type of street. A local street with residences will require different sidewalk dimensions than a boulevard with commercial establishments. The descriptions below indicate the type of pedestrian activity expected at each of the specified land uses. The graphics (credit Marty Bruinsma) illustrate the minimum widths of the sidewalk zones for each of the contexts. The matrix in the following section provides specific minimum requirements for the four sidewalk zones according to combinations of land use and street classifications.



### LOW / MEDIUM DENSITY RESIDENTIAL

These streets are typically quieter than others and generally do not carry transit vehicles or high volumes of traffic. Pedestrians require a pleasant walking environment within these neighborhoods, as well as to access land uses and transit on nearby streets. Of the four sidewalk zones, the furniture zone is often the widest, to provide room for street trees.

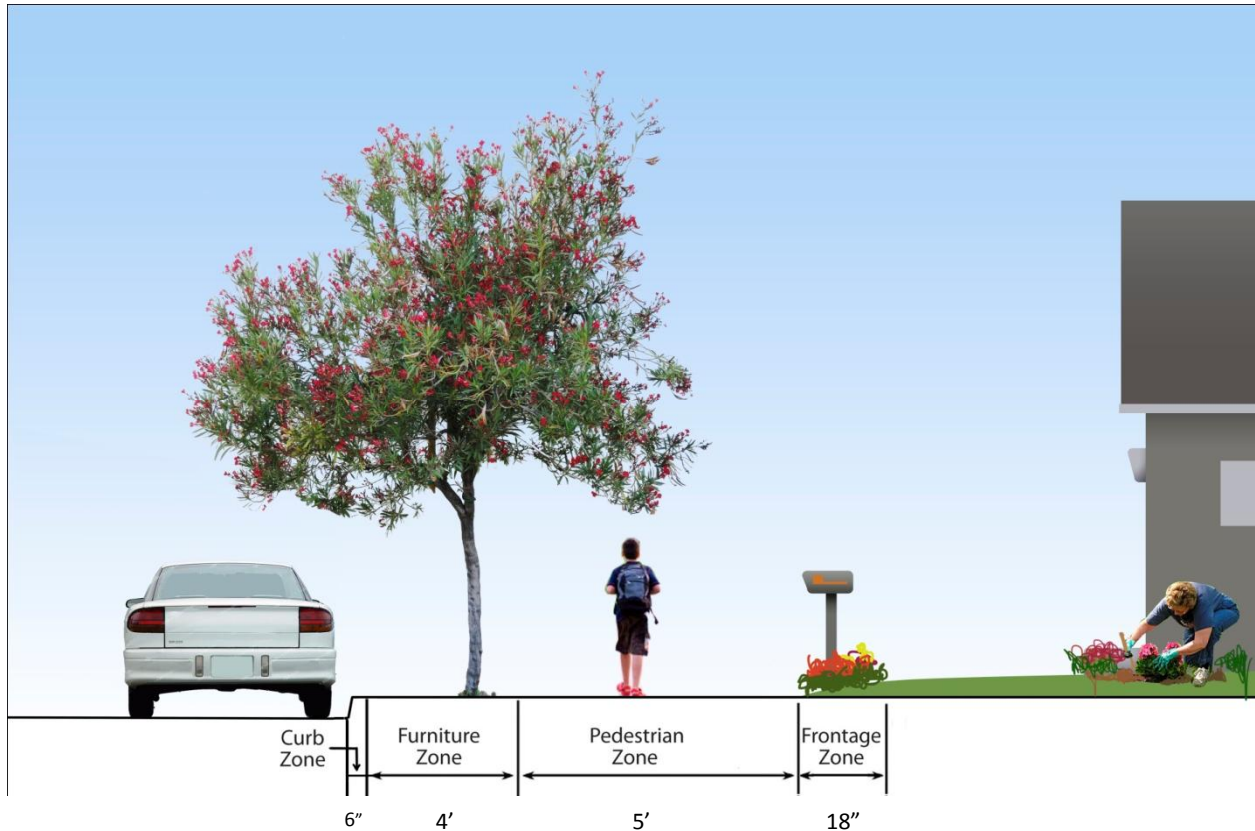

Please note that the dimensions shown above are only the minimum required dimensions. The pedestrian zone refers to the minimum clear width of usable sidewalk space for pedestrians, not necessarily the actual width of the sidewalk.



### MEDIUM / HIGH DENSITY RESIDENTIAL

These streets support greater volumes of pedestrians. Streets with transit service require good pedestrian links to bus stops. The pedestrian zone should be wider than in low/medium density residential.

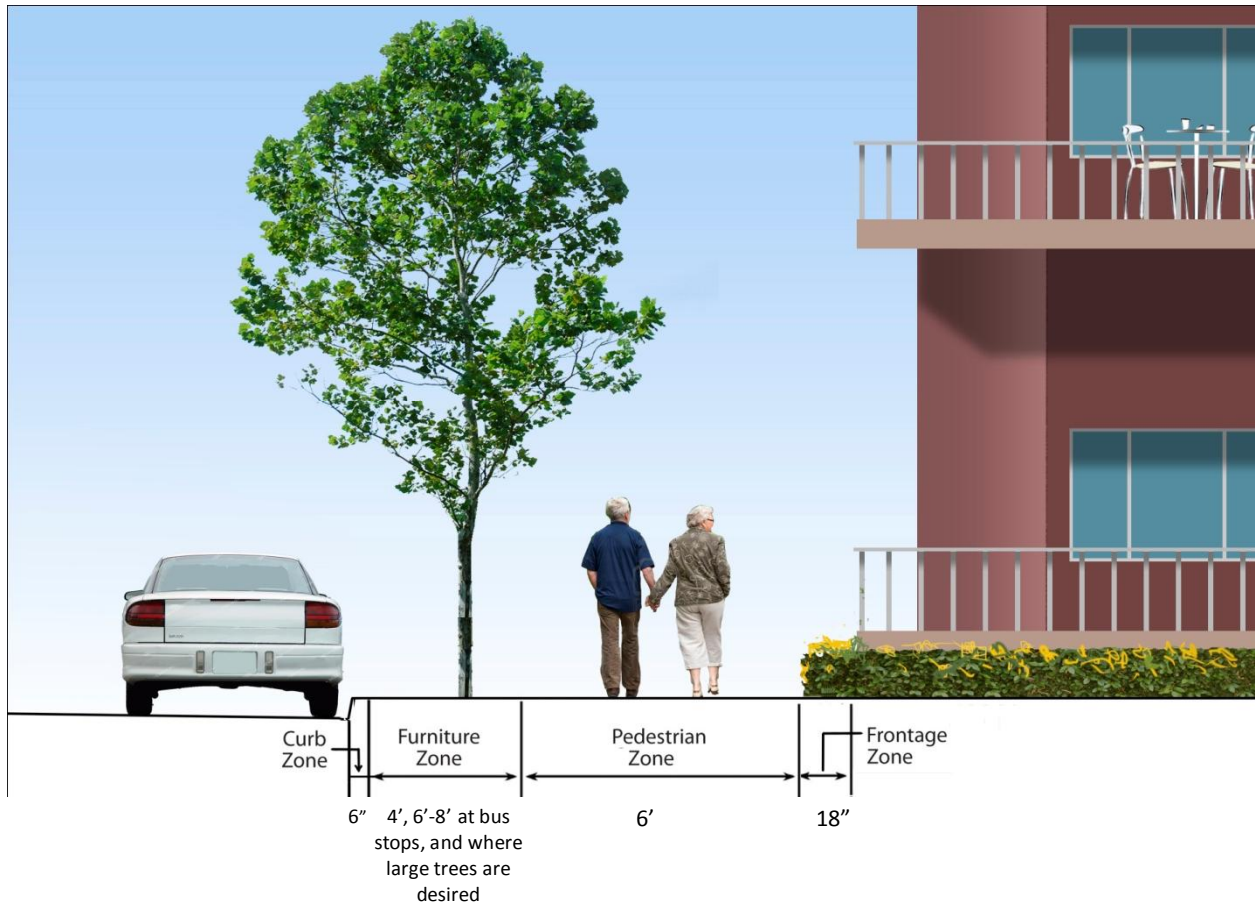

Please note that the dimensions shown above are only the minimum required dimensions. The pedestrian zone refers to the minimum clear width of usable sidewalk space for pedestrians, not necessarily the actual width of the sidewalk.

### NEIGHBORHOOD COMMERCIAL

These streets often have grocers, laundromats, drug stores, and other neighborhood-serving retail establishments. Sidewalks in neighborhood commercial areas should accommodate pedestrians walking from residences to stores. Of the four sidewalk zones, the pedestrian zone should be the widest, with a generous frontage zone to provide room for features next to buildings such as newspaper boxes. These sidewalks should also be designed with the understanding that cars will cross sidewalks as they enter and exit commercial driveways.



### GENERAL / REGIONAL COMMERCIAL

These streets have retail, office, civic, and recreational uses concentrated along boulevards and avenues. Transit service runs along these streets and pedestrians need buffers from traffic. Of the four sidewalk zones, the pedestrian and furniture zones are favored. These sidewalks also should be designed with the understanding that a significant number of cars will cross sidewalks as they enter and exit commercial driveways.

### MIXED / MULTI-USE

The sidewalks along these streets should support significant pedestrian volumes due to their integrated nature and higher densities. Of the four sidewalk zones, the pedestrian and frontage zones will be favored. Transit service runs along these streets and sidewalks will require buffers from traffic.

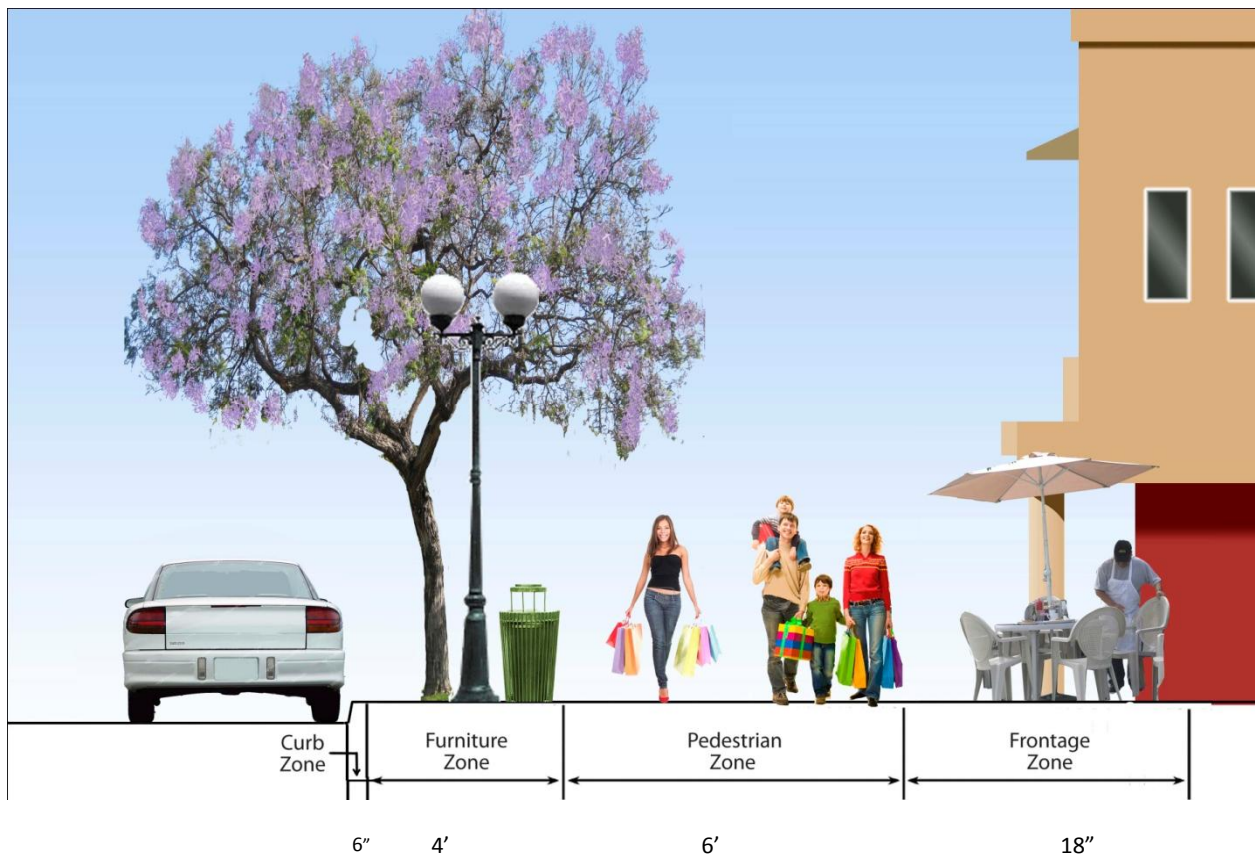

Please note that the dimensions shown above are only the minimum required dimensions. The pedestrian zone refers to the minimum clear width of usable sidewalk space for pedestrians, not necessarily the actual width of the sidewalk.



## INDUSTRIAL

Industrial streets are zoned for manufacturing, office warehousing, and distribution. Pedestrian volumes are likely to be lower here given that these land uses typically employ fewer people per square foot than general commercial areas. Employees will need good sidewalks to get to work.

## DOWNTOWN CORE/MAIN STREET

The downtown core or Main Street is a pedestrian-oriented area. This is where the greatest numbers of pedestrians are encouraged and expected. The downtown core serves as the retail, restaurant, and entertainment center of a community. This area will need the widest sidewalks, the widest crosswalks, the brightest street lighting, the most furnishings, and other features that will enhance the pedestrian environment. Of the four sidewalk zones, the pedestrian and frontage zones will be favored, with a furniture zone wide enough for street trees.

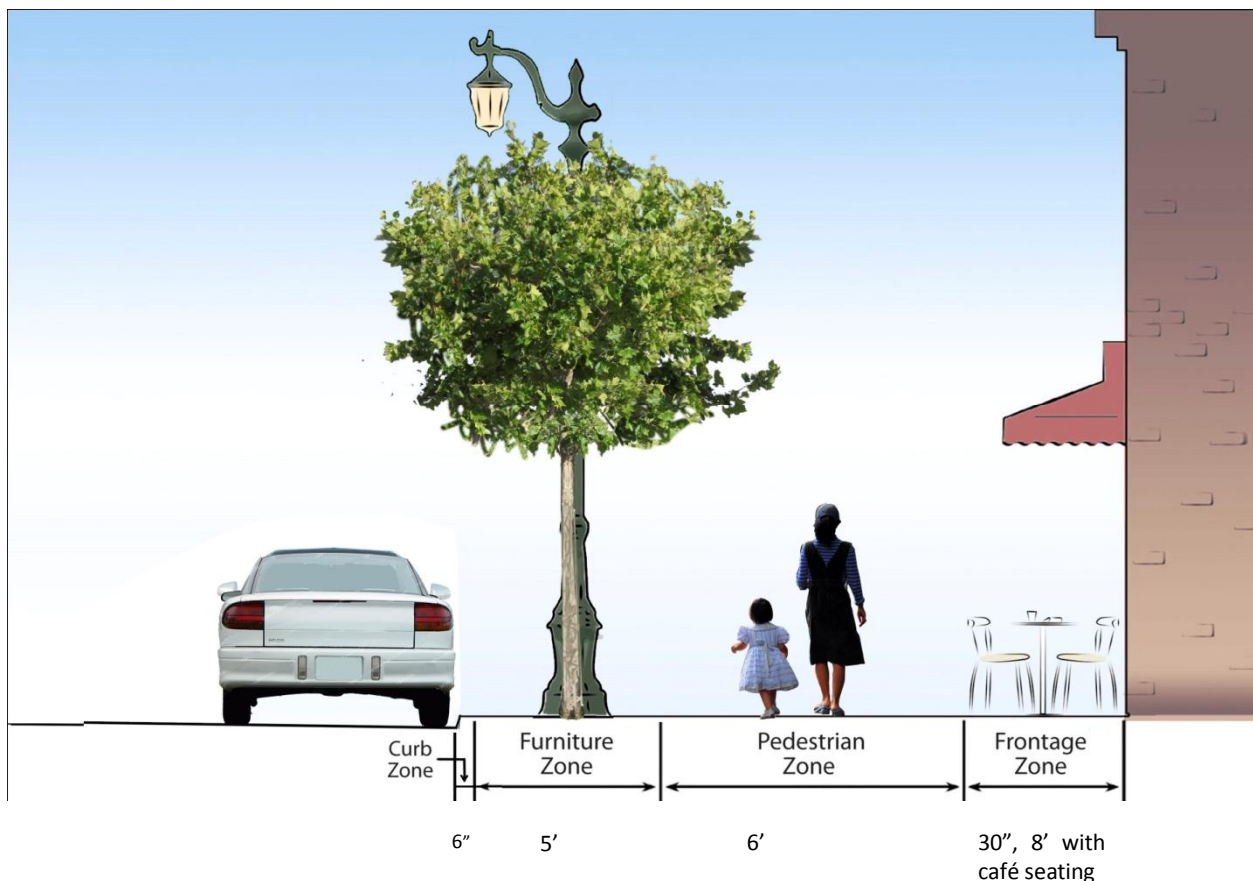

Please note that the dimensions shown above are only the minimum required dimensions. The pedestrian zone refers to the minimum clear width of usable sidewalk space for pedestrians, not necessarily the actual width of the sidewalk.



OFFICE PARK

These streets are home to national and regional offices of financial institutions, government, large companies, and other uses. Local jurisdictions can expect pedestrians during the morning and evening commutes walking to and from their cars and bus stops. Visitors will use the sidewalks throughout the day and employees will need them during the lunch hour. The furniture zone should provide adequate buffer from parking lots.

PUBLIC FACILITIES

Public facilities streets, particularly streets near schools, libraries, and civic centers, require special attention and treatment. High pedestrian volumes are expected during peak times, such as school pick-up and drop-off, and during the morning and evening commute hours. Sidewalk design should accommodate these peak travel times and include adequate furniture zones to buffer pedestrians from the street. Public facilities are located in various types of streets ranging from local streets to boulevards with transit service.

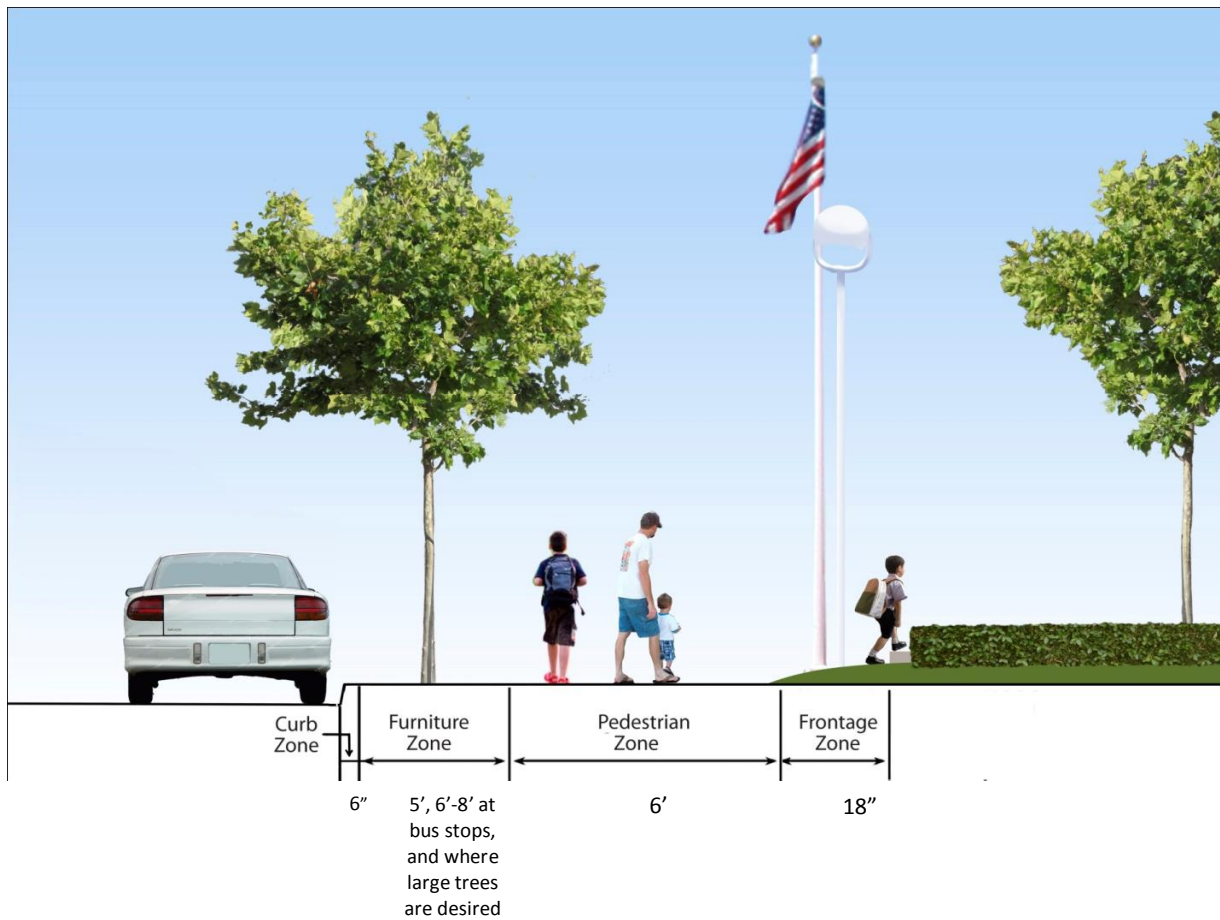



Please note that the dimensions shown above are only the minimum required dimensions. The pedestrian zone refers to the minimum clear width of usable sidewalk space for pedestrians, not necessarily the actual width of the sidewalk.

### DESIGN SPECIFICATIONS BY ROADWAY TYPE AND LAND USE

Table 7.2 lists minimum widths for the frontage, pedestrian, furniture, and curb zones, as well as minimum total widths. These minimums should not be considered the design width; in many cases, wider zones will be needed.

**Table 7.2 Sidewalk Zone Widths for Each Land Use Context**

	Boulevard	Avenue	Street
Low / Medium-Density Residential	Not applicable	Frontage: 18" Pedestrian: 5' Furniture: 4', 6'-8' at bus stops, and where large trees are desired Curb: 6"  Min. Width: 11'	Frontage: 18" Pedestrian: 5' Furniture: 4' Curb: 6"  Min. Width: 11'
Med / High Density Residential	Frontage: 18" Pedestrian: 6' Furniture: 5', 6'-8' at bus stops, and where large trees are desired Curb: 6"  Min. Width: 13'	Frontage: 18" Pedestrian: 6' Furniture: 5', 6'-8' at bus stops, and where large trees are desired Curb: 6"  Min. Width: 13'	Frontage: 18" Pedestrian: 6' Furniture: 4', 6'-8' at bus stops, and where large trees are desired Curb: 6"  Min. Width: 12'
Neighborhood Commercial	Not applicable	Frontage: 18" Pedestrian: 6' Furniture: 5', 6'-8' at bus stops, and where large trees are desired Curb: 6"  Min. Width: 13'	Frontage: 18" Pedestrian: 6' Furniture: 4', 6'-8' at bus stops, and where large trees are desired Curb: 6"  Min. Width: 12'
General Commercial	Frontage: 18" Pedestrian: 6' Furniture: 5', 6'-8' at bus stops, and where large trees are desired Curb: 6"  Min. Width: 13'	Frontage: 18" Pedestrian: 6' Furniture: 5', 6'-8' at bus stops, and where large trees are desired Curb: 6"  Min. Width: 13'	Not Applicable



	Boulevard	Avenue	Street
Mixed / Multi-use	Frontage: 30", 8' with café seating Pedestrian: 6' Furniture: 5', 6'-8' at bus stops, and where large trees are desired Curb: 6"  Min. Width: 14'	Frontage: 30", 8' with café seating Pedestrian: 6' Furniture: 4', 6'-8' at bus stops, and where large trees are desired Curb: 6"  Min. Width: 13'	Frontage: 18" Pedestrian: 6' Furniture: 4' Curb: 6"  Min. Width: 12'
Industrial	Frontage: 18" Pedestrian: 5' Furniture: 5' Curb: 18"  Min. Width: 13'	Frontage: 18" Pedestrian: 5' Furniture: 4' Curb: 18"  Min. Width: 12'	Frontage: 18" Pedestrian: 5' Furniture: 4' Curb: 18"  Min. Width: 12'
Downtown Core / Main Street	Frontage: 30", 8' with café seating Pedestrian: 6' Furniture: 5', 6'-8' at bus stops, and where large trees are desired Curb: 6"  Min. Width: 14'	Frontage: 30", 8' with café seating Pedestrian: 6' Furniture: 5', 6'-8' at bus stops, and where large trees are desired Curb: 6"  Min. Width: 14'	Frontage: 30", 8' with café seating Pedestrian: 6' Furniture: 5' Curb: 6"  Min. Width: 14'
Transit Oriented Districts	Frontage: 30" Pedestrian: 8' Furniture: 5', 6'-8' at bus stops, and where large trees are desired Curb: 6"  Min. Width: 16'	Frontage: 30" Pedestrian: 8' Furniture: 5', 6'-8' at bus stops, and where large trees are desired Curb: 6"  Min. Width: 16'	Frontage: 18" Pedestrian: 6' Furniture: 5', 6'-8' at bus stops, and where large trees are desired Curb: 6"  Min. Width: 13'
Office Park	Frontage: 18" Pedestrian: 5' Furniture: 5' Curb: 6"  Min. Width: 12'	Frontage: 18" Pedestrian: 5' Furniture: 5' Curb: 6"  Min. Width: 12'	Not Applicable
Public Facilities	Frontage: 30" Pedestrian: 8' Furniture: 5', 6'-8' at bus stops, and where large trees are desired Curb: 6"  Min. Width: 16'	Frontage: 30" Pedestrian: 8' Furniture: 5', 6'-8' at bus stops, and where large trees are desired Curb: 6"  Min. Width: 16'	Frontage: 18" Pedestrian: 6' Furniture: 5', 6'-8' at bus stops, and where large trees are desired Curb: 6"  Min. Width: 13'



## GENERAL GUIDELINES

The land uses included in the previous table cover those of most municipalities. For those few areas not covered, the following list provides general guidelines for sidewalks:

- The recommended minimum frontage zone width is 18 inches.
- The recommended minimum pedestrian zone width is 5 feet.
- The recommended minimum curb zone width is 6 inches or 18 inches where pedestrian or freight loading is expected and may conflict with obstacles in the furniture zone.
- The recommended minimum furniture zone width is 4 feet and 6 feet to 8 feet where bus stops exist.
- Low curbs (3 to 4 inches high) reduce the division between the traveled way and the sidewalk. They are favored in areas with significant pedestrian traffic. Low curbs also improve the geometry and feasibility of providing two perpendicular curb ramps per corner.

Some judgment may be needed on a case-by-case basis to establish actual widths of each of the four zones.

## FOR MORE INFORMATION

### Primary:

Americans with Disabilities Act Accessibility Guidelines (ADAAG)

Public Right-of-Way Accessibility Guidelines (PROWAG)

### Secondary:

Federal Highway Administration (FHWA). *Manual on Uniform Traffic Control Devices, "MUTCD."* 2009.

American Association of State Highway Transportation Officials (AASHTO). *A Policy on the Geometric Design of Highways and Streets, 6<sup>th</sup> Edition, "AASHTO Green Book."* 2011.

Federal Highway Administration (FHWA). *Designing Sidewalks and Trails for Access.* 2001.

NCHRP Project 20-7 (232), *ADA Transition Plans: A Guide to Best Management Practices.* 2009.

NCHRP Project 3-62, *Guidelines for Accessible Pedestrian Signals.* 2007.



This page left blank intentionally.



## 8. PEDESTRIAN CROSSINGS

INTRODUCTION.....	1
ESSENTIAL PRINCIPLES OF PEDESTRIAN CROSSINGS .....	2
FLORIDA STATE STATUTES RELATED TO PEDESTRIAN CROSSINGS.....	4
PERFORMANCE MEASURES .....	4
PEDESTRIAN CROSSING TOOLBOX.....	5
Marked Crosswalks .....	5
Raised Crossing Islands/Medians.....	11
Raised Crosswalks .....	13
Curb Extensions.....	13
All-Pedestrian Phases .....	14
Signs.....	16
Advanced Yield/Stop Lines .....	17
Lighting .....	17
Rectangular Rapid Flashing Beacon (RRFB) .....	18
Pedestrian Hybrid Beacon .....	19
Pedestrian Toolbox for Railroad Crossings.....	20



*(Credit: Kimley-Horn and Associates, Inc.)*



## INTRODUCTION

Walking requires two important features in the built environment: people must walk along streets and they must get across streets. Crossing a street should be easy, safe, convenient, and comfortable. While pedestrian behavior and intersection or crossing design affect the street crossing experience, motorist behavior (whether and how motorists stop for pedestrians) is the most significant factor in pedestrian safety.



*Crossings are a necessary part of the pedestrian experience  
(Credit: Luisa Fernanda Arbeláez)*

Pedestrian networks and vehicle networks overlap at intersections, posing conflicts between different modes of travel. A number of tools exist to improve pedestrian safety and to make crossing streets easier. Effective traffic management can address concerns about traffic speed and volume. A motorist driving more slowly has more time to see, react, and stop for a pedestrian. The number of pedestrians also influences motorists; in general, motorists are more aware of pedestrians when more people walk. Most tools to address crossing challenges are engineering treatments, but tools from the enforcement, education, and planning toolboxes are also important.

***"I just want to be able to cross the street safely."***

- City of Deerfield Beach  
Mayor Peggy Noland

Marked crosswalks guide pedestrians to walk at the safest location. To a lesser extent, marked crosswalks also alert vehicle operators to the potential presence of pedestrians, although crosswalks can be less visible from the perspective of moving traffic, which is one reason for supplementing crosswalks with pedestrian warning (W11-2) signs. Providing marked crosswalks is only one of the many possible engineering measures. When considering how to provide safer crossings for pedestrians, the question should *not* be: "Should I provide a marked crosswalk?" Instead, the question should be: "What are the most effective measures that can be used to help pedestrians safely cross the street?" For example, crossings often need to be supplemented with median refuges, flashing beacons, and signage. Deciding whether to mark or not mark crosswalks is only one consideration in creating safe and convenient pedestrian crossings.



This chapter describes a number of measures to improve pedestrian crossings, including marked and unmarked crosswalks, raised crossing islands and medians, beacons, and lighting.

## ESSENTIAL PRINCIPLES OF PEDESTRIAN CROSSINGS

The following principles should be incorporated into every pedestrian crossing improvement:

- Pedestrians must be able to cross roads safely. FDOT and local governments have an obligation to provide safe and convenient crossing opportunities.
- The safety of all street users, particularly more vulnerable groups, such as children, the elderly, and those with disabilities, and more vulnerable modes, such as walking and bicycling, must be considered when designing streets.
- Pedestrian crossings must meet accessibility standards and guidelines (see Chapter 7 “Universal Pedestrian Access” for more information).



*Curb extensions and medians make crossing four-lane streets safer and more manageable. Note the use of an in-street pedestrian crossing sign to alert motorists.  
(Credit: Dan Burden)*

*A crash modification factor (CMF) is a multiplicative factor used to compute the expected number of crashes after implementing a given countermeasure at a specific site consistent with the FHWA Highway Safety Manual. For example, if a median refuge island at an existing crosswalk is expected to reduce the number of crashes by 23 percent, the CMF will be  $1 - (23/100) = 0.77$ .*

Real and perceived safety must be considered when designing crosswalks — crossing the street must be “comfortable.”

- Crossing treatments that have the best crash modification factors (CMFs) should be used when designing crossings.
- Safety should not be compromised to accommodate traffic flow.
- Good crossings begin with appropriate speed. In general, urban arterials should be designed to a maximum of 30 mph or 35 mph.
- Every crossing is different and should be selected and designed to fit its unique environment.

The following issues should also be considered when planning and designing crossings.

- Ideally, uncontrolled crossing distances should be no more than 28 feet, which allows for two 11-foot lanes and one 6-foot bicycle lane. This would allow pedestrians to cross



an uncontrolled crossing in 8 seconds, assuming a conventional walking speed of 3.5 feet per second.

- Uncontrolled crosswalks should still be considered if the crossing distance is greater than 28 feet within a context sensitive approach, such as in locations where transit passengers cross the street, in urban transects (T4, T5 or T6), where marked crosswalks would effectively channel pedestrians to a single crossing location, and unsignalized intersections with no signalized crossing within 600 feet (see *Accessing Transit: Designing Handbook for Florida Bus Passenger Facilities*, Florida State University (2008), accessed from FDOT Transit website).
- Uncontrolled crosswalks on streets wider than 28 feet should be augmented with additional crossing safety devices. Ideally, streets wider than 28 feet should be divided (effectively creating two streets) by installing a median or crossing islands, especially when traffic volumes are greater than 12,000 vehicles per day. According to *Safety Effects of Marked Versus Unmarked Crosswalks at Uncontrolled Locations* (Zegeer et al, 2005), on multi-lane roads with traffic volumes above 12,000 vehicles per day, having a marked crosswalk alone (without other substantial crossing safety improvements) was associated with a higher pedestrian crash rate compared to an unmarked crosswalk. Substantial crossing safety improvements were considered to include raised medians, speed-reducing measures (traffic calming), traffic signals, and beacons.
- The number of lanes crossed should be limited to a maximum of three lanes per direction on all roads (plus a median or center turn lane).
- There must be a safe, convenient crossing at every transit stop.
- Double (or triple) left or right turns concurrent (permissive) with pedestrian crossings at signalized intersections must never be allowed.
- Avoid concurrent movements of motor vehicles and people at signalized intersections, with the exception of right-turns from single lanes, which should be supplemented with R10-15 signs and tight corner radii to control speeds.
- People should never have to wait more than 90 seconds to cross at signalized intersections.
- Pedestrian signals should be provided at all signalized crossings where pedestrians are allowed.
- Marked crosswalks should be provided on all approaches of signalized intersections.
- Locations where pedestrian bulb-outs can be provided can enhance the viability of a crossing location.



MUTCD R10-15 sign

(Credit: Kimley-Horn and Associates, Inc.)



## FLORIDA STATE STATUTES RELATED TO PEDESTRIAN CROSSINGS

Florida traffic laws for pedestrians and drivers are found in *Florida State Statute 316.003*, *316.075*, and *316.130*. A brief summary is provided below.

- Crosswalks may be marked or unmarked and carry the same legal definition whether marked or unmarked.
- Any intersection of two public streets is a legal crossing, and is therefore a strong candidate to include marked crosswalks, signage, and pedestrian crossing safety infrastructure.
- Mid-block crossing outside a crosswalk is allowed if in either direction, the nearest intersection is unsignalized.
- A driver is obligated to yield the right-of-way to a pedestrian lawfully crossing in a crosswalk. Safe yielding may require stopping.
- A crosswalk is legally present on each leg of an intersection whether marked or unmarked.

## PERFORMANCE MEASURES

Performance measures are typically used to study uncontrolled crossing locations. Performance measures establish how well a crossing is performing. In all cases, baseline data should be collected to allow for before and after analysis. Performance measures for pedestrian crossings include the following.

- The number of pedestrians crossing at a particular crossing location increases.
- The pedestrian crash rates decrease (for an accurate determination, entire corridors should be analyzed since crashes at any one location may be infrequent).
- Pedestrian fatalities and serious injuries should decrease.
- The numbers of children, seniors, and people with disabilities crossing the street should reflect their percentage in the vicinity population.



*Lively streets with many pedestrians and comfortable crossing environments indicate a walkable neighborhood, such as Lauderdale-By-The-Sea  
(Credit: Kimley-Horn and Associates, Inc.)*



- The speed of motorists either turning at an intersection or traveling at a mid-block crossing decreases.
- Motorists do not block intersections (including crosswalks).
- At uncontrolled intersections, the percentage of motorists who stop for pedestrians goes up (measure compliance with stop or yield requirement in local vehicle code).

## PEDESTRIAN CROSSING TOOLBOX

Many engineering measures may be used at a pedestrian crossing, depending on site conditions and potential users. Marked crosswalks are commonly used at intersections and sometimes at mid-block locations. Marked crosswalks are often the first measure in the toolbox followed by a series of other measures that are used to enhance and improve marked crosswalks. The decision to mark a crosswalk should not be considered in isolation, but rather in conjunction with other measures to increase awareness of pedestrians. Without additional measures, marked crosswalks alone may not increase pedestrian safety, particularly on multi-lane streets.

### MARKED CROSSWALKS

Crosswalks are present by law on all approaches of all intersections, whether marked or unmarked, whether signalized or unsignalized, unless the pedestrian crossing is specifically prohibited by signs. At mid-block locations, crosswalks only exist where marked. Note that mid-block crossings are legally allowed if the nearest intersection in each direction is unsignalized. Crosswalks should be considered at mid-block locations where there is strong evidence that pedestrians want to cross there, due to origins and destinations across from each other and an overly long walking distance to the nearest controlled crossing (see mid-block crossing sub-section below). Marked crosswalks alert drivers to expect crossing pedestrians and direct pedestrians to desirable crossing locations. Although many motorists are unaware of their precise legal obligations at crosswalks, the Florida Uniform Traffic Control Law requires drivers to yield to pedestrians in any crosswalk, whether marked or unmarked. Marking crosswalks at every intersection is not necessary or desirable.

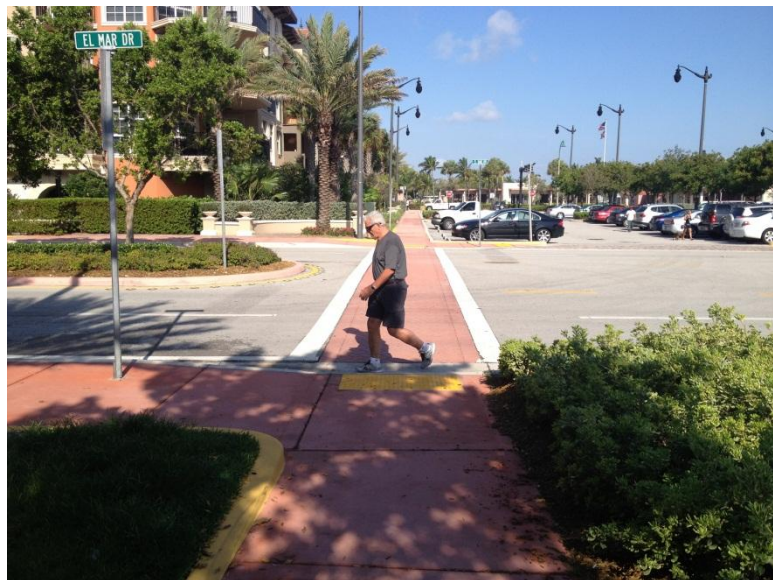

*Marked crosswalk. If decorative treatment is applied it shall be bordered by solid white line crosswalk markings.  
(Credit: Kimley-Horn and Associates, Inc.)*



### Crosswalk Markings

According to the MUTCD, the minimum crosswalk marking shall consist of solid white lines. They shall not be less than 6 inches or greater than 24 inches in width. FDOT Standard Index 17346 states that crosswalk lines shall be a minimum of 12 inches in width. Local jurisdictions should follow the 12 inch minimum standard for crosswalk markings.

### Placement

The best locations to install marked crosswalks are as follows.

- All signalized intersections
- Crossings near transit locations
- Shared use path crossings
- High-pedestrian land use generators
- School walking routes
- Where there is a preferred crossing location due to sight distance
- Where needed to enable comfortable crossings of multi-lane streets between controlled crossings spaced at convenient distances
- Unsignalized intersections in urban transects (T4, T5, or T6)
- Unsignalized intersections with no signalized crossing within 600 feet

### Controlled Intersections

Intersections can be controlled by traffic signals or STOP signs. Marked crosswalks should be provided on all intersection legs controlled by traffic signals, unless the pedestrian crossing is specifically prohibited by signs. Marked crosswalks may be considered at STOP-controlled intersections. Factors to be considered include high pedestrian volumes, high vehicle volumes, school zone location, high volume of elderly or disabled users, or other safety related criteria.



*Pedestrian crossing at a controlled intersection  
(Credit: Luisa Fernanda Arbeláez)*

Uncontrolled Intersections

Intersections without traffic signals or STOP signs are considered uncontrolled intersections. The decision to mark a crosswalk at an uncontrolled intersection should be guided by an engineering study. Factors considered in the study should include vehicular volumes and speeds, roadway width and number of lanes, stopping sight distance and triangles, distance to the next controlled crossing, night time visibility, grade, origin-destination of trips, left turning conflicts, and pedestrian volumes. The engineering study should be based on the FHWA study, *Safety Effects of Marked Versus Unmarked Crosswalks at Uncontrolled Locations* (Zegeer et al, 2005). The following list provides some of the key recommendations from the study.

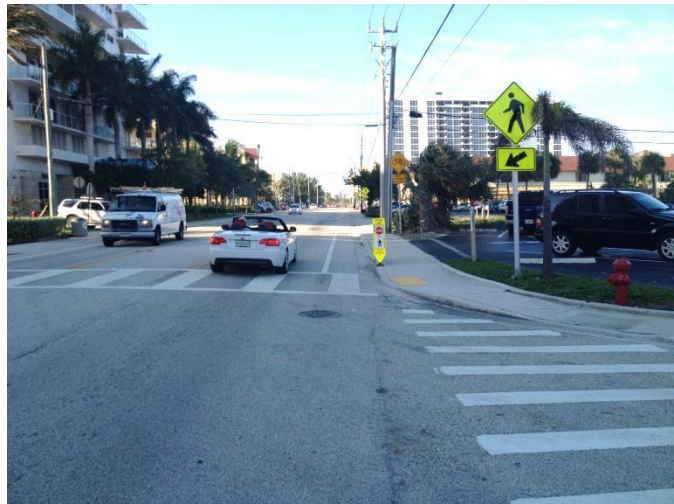

*Pedestrian crossing at an uncontrolled intersection  
 (Credit: Kimley-Horn and Associates, Inc.)*

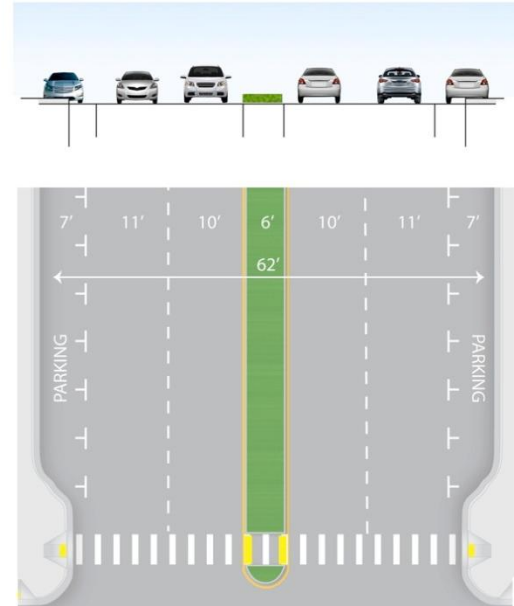
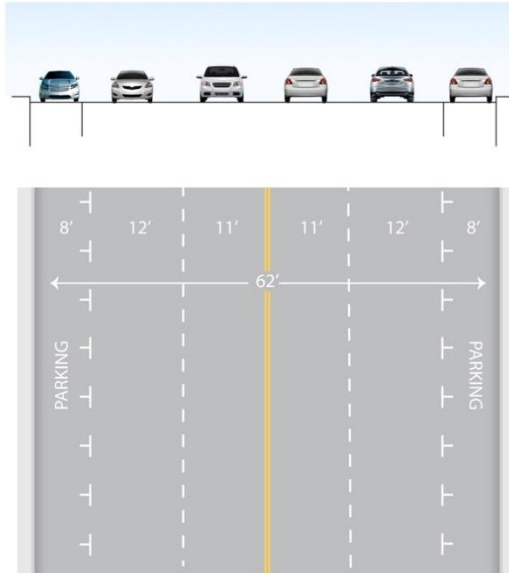

*Uncontrolled crossings of four-lane streets can be difficult to cross without special treatments like medians and curb extensions.  
 (Credit: Michele Weisbart)*



- It is permissible to mark crosswalks at uncontrolled locations on two-lane roadways.
- On multi-lane roadways, uncontrolled marked crosswalks *should be enhanced by additional safety features* under the following conditions (the other tools listed in this section can be considered to enhance the crosswalk):
  - ADT > 12,000 w/o median
  - ADT > 15,000 w/ median
  - Speeds greater than 40 mph
- Raised medians can be used to reduce risk.
- Signals or other treatments should be considered where there are many young and/or elderly pedestrians.

### Mid-block Crosswalks

A mid-block crosswalk can be controlled or uncontrolled.

A controlled mid-block crosswalk includes a traffic signal to control motor vehicles based on pedestrian-actuation of the signal. Although the pedestrian crossing traffic signal is not the sole solution to facilitating pedestrian access to street crossings, it is often a necessary solution at multi-lane facilities having high vehicular volume. The mid-block pedestrian signal should be guided by an engineering study and a comparison to the signal warrants found in the MUTCD.

Uncontrolled mid-block crosswalks can also be provided under certain circumstances. The criteria for marking an uncontrolled mid-block crosswalk provided below are adapted from the Center for Urban Transportation Research (CUTR) report *Pedestrian Safety at Midblock Locations* (Chu, 2006).

- **Pedestrian Demand.** Any block under consideration for a possible mid-block crosswalk should show a well-defined pattern of pedestrian generators, pedestrian attractors, and pedestrian flow between them. Considerations should also include presence of bus stops. Sufficient pedestrian crossing demand generally is 25 pedestrians during the peak hour



*Controlled mid-block pedestrian crossing; note traffic signal structure overhead  
(Credit: Kimley-Horn and Associates, Inc.)*



*Uncontrolled mid-block pedestrian crossing  
(Credit: Kimley-Horn and Associates, Inc.)*



of pedestrian crossing traffic or 75 pedestrians during the peak four hours of pedestrian crossing traffic.

- **Shared-Use Path Crossing.** Well-designed mid-block crosswalks should be strongly considered at any mid-block location that is an integral part of a designated shared-use path regardless of demand.
- **Existence of Alternatives.** The minimum distance to the nearest controlled or protected crossing is 300 feet. A well-designed crossing should be provided at least every 660 feet in urbanized areas.
- **Traffic Volume.** For local streets, a minimum threshold for average daily traffic typically falls in the range of 1,500 to 3,000. Above the following average daily traffic and speed thresholds as presented in the Uncontrolled Intersections sub-section, mid-block crossings should be augmented with enhanced safety devices.
  - ADT > 12,000 w/o median
  - ADT > 15,000 w/ median
  - Speeds greater than 40 mph
- **Stopping Sight Distance.** Stopping sight distance should be calculated and compared to minimum sight distance criteria found in the *FDOT Plans Preparation Manual (PPM)* Chapter 2 or AASHTO guidance. The consideration of sight distance should account for the presence of on-street parking when applicable.
- **Lighting.** A minimum illumination level of 2.5 horizontal foot-candles shall be used for both approaches. When regular street lighting is not present or is inadequate to reach this minimum illumination level, separate crosswalk lighting shall be installed. Crossing locations with high night-time demand should include separate crosswalk lighting, which may include in-street lighting.

These basic safety criteria are consistent with MUTCD guidance and help achieve the objective of increasing positive effects of marked crosswalks while reducing negative behavioral adaptation.

### Frequency of Marked Crosswalks at Uncontrolled Locations

Along urban streets, a well-designed crossing should be provided at least every 1/8 mile (660 feet). Marked crosswalks should be spaced so people can cross at preferred locations. If people are routinely crossing streets at non-preferred locations, consideration should be given to installing a new crossing. Pedestrians need crossings with appropriate devices (islands, curb extensions, advanced yield lines, etc.) on multi-lane streets where there are strong desire lines.

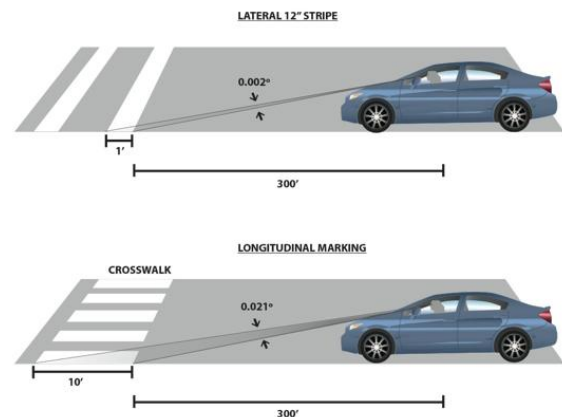

*Longitudinal crosswalk markings are more visible than lateral crosswalk markings  
(Credit: Michele Weisbart)*

Special Emphasis Crosswalks

Because of the low approach angle at which pavement markings are viewed by drivers, the use of longitudinal stripes in addition to or in place of transverse markings can significantly increase the visibility of a crosswalk to oncoming traffic. While research has not shown a direct link between increased crosswalk visibility and increased pedestrian safety, special emphasis crosswalks have been shown to increase motorist yielding and channelization of pedestrians, leading the Federal Highway Administration to conclude that high-visibility pedestrian crosswalks have a positive effect on pedestrian and driver behavior.



*FDOT special emphasis crosswalk; note this design may have been improved by a channelization island for refuge  
 (Credit: Kimley-Horn and Associates, Inc.)*

Colored and stamped crosswalks should only be used at controlled locations, and should always be bordered by white lines.

Local jurisdictions should be consistent with FDOT criteria for special emphasis crosswalks

- Lines must always be white
- Longitudinal stripes must be 24 inches wide
- Longitudinal stripes should be spaced to avoid the wheel-paths of vehicles up to a maximum spacing of 60 inches.



*Decorative crosswalk treatments made of distinctive materials can become uneven over time.  
 (Credit: Ryan Snyder)*

Crosswalks and Accessibility

The Pedestrian Access Route continues through the crosswalk and must conform to the surface condition, width, and slope requirements discussed in Chapter 7, “Universal Pedestrian Access.”

Longitudinal crosswalk markings provide the best visibility for pedestrians with limited vision.

Decorative crosswalk pavement materials should be chosen with care to ensure that smooth surface conditions and high contrast with surrounding



pavement are provided. Textured materials within the crosswalk are not recommended. Without reflective materials, these treatments are not visible to drivers at night. Decorative pavement materials often deteriorate over time and become a maintenance problem while creating uneven pavement. The use of color or material to delineate the crosswalks as a replacement of retro-reflective pavement marking should not be used, except in slow speed districts where intersecting streets are designed for speeds of 20 mph or less.

### RAISED CROSSING ISLANDS/MEDIANS

Raised islands and medians are the most important, safest, and most adaptable engineering tool for improving street crossings. *Note on terminology: a median is a continuous raised area separating opposite flows of traffic. A crossing island is shorter and located just where a pedestrian crossing is needed.* Raised medians and crossing islands are commonly used between intersections when blocks are long (500 feet or more in downtowns) and in the following situations:



*Staggered median crossing  
(Credit: Marcel Schmaedick)*

- Speeds are higher than desired
- Streets are wide
- Traffic volumes are high
- Sight distances are poor

Raised islands have nearly universal applications and should be placed where there is a need for people to cross the street. They are also used to slow traffic.

Raised crossing islands and medians have been identified by FHWA as the most effective tool to enhance crossing safety (*Pedestrian Countermeasure Policy Best Practice Report*, FHWA, and *Pedestrian Safety Engineering and ITS-Based Countermeasures*, FHWA).

#### Reasons for Efficacy

The use of raised crossing islands and medians changes a complex task, crossing a wide street with traffic coming from two opposing directions all at once, into two simpler and smaller tasks. With their use, conflicts occur in only one direction at a time, and exposure time can be reduced from more than 20 seconds to just a few seconds.

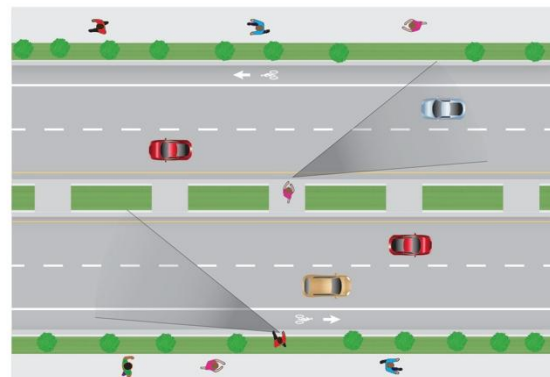

*Medians and crossing islands allow pedestrians to complete the crossing in two stages.  
(Credit: Michele Weisbart)*



On streets with traffic speeds higher than 30 mph, it may be unsafe to cross without a median island. At 30 mph, motorists travel 44 feet each second, placing them 880 feet out when a pedestrian starts crossing an 80-foot wide multi-lane road. In this situation, this pedestrian may still be in the last travel lane when the car arrives there; that car was not within view at the time he or she started crossing. With an island on multi-lane roadways, people would cross two or three lanes at a time instead of four or six. Having to wait for a gap in only one direction of travel at a time significantly reduces the wait time to cross. Medians and crossing islands have been shown to reduce crashes by 40 percent (*Designing for Pedestrian Safety course, FHWA*).

As a general rule, crossing islands are preferable to signal-controlled crossings due to their lower installation and maintenance cost, reduced waiting times, and their safety benefits. Crossing islands are also used with road diets, taking four-lane undivided, high-speed roads down to better performing three-lane roadways (two travel lanes and a center turn lane); portions of the center turn lane can be dedicated to crossing islands. Crossing islands can also be used with signals.

Angled pedestrian crossings through pedestrian refuges (as shown in the photo below) force pedestrians to look for oncoming vehicles.



*Angled median crossing  
(Credit: Paul Zykofsky)*

### Where to Place Crossing Islands

Crossing islands are often used for trails, high pedestrian flow zones, transit stations, schools, work centers, and shopping districts.

### Design Detail

Crossing islands, like most traffic calming features, perform best with both tall trees and low ground cover. This greatly increases their visibility, reduces surprise, and lowers the need for a plethora of signs. When curves or hill crests complicate



*Multiple tools can be employed to improve uncontrolled crossings.  
(Credit: Dan Burden)*



*Crossing islands: Berkeley, CA  
(Credit: Ryan Snyder)*

crossing locations, median islands are often extended over a crest or around a curve to where motorists have a clear (six second or longer) sight line of the downstream change in conditions. Lighting of median islands is essential. The suggested minimum width of a crossing island is 6 feet. When used on higher speed roads, and where there is space available, inserting a 45-degree bend to the right helps orient pedestrians to the risk they encounter from motorists during the second half of their crossing.

### RAISED CROSSWALKS

Raised crosswalks slow traffic and put pedestrians in a more visible position. They are trapezoidal in shape on both sides and have a flat top where the pedestrians cross. The level crosswalk area must be paved with smooth materials; any texture or special pavements used for aesthetics should be placed on the beveled slopes, where they will be seen by approaching motorists. They are most appropriate in areas with significant pedestrian traffic and where motor vehicle traffic should move slowly, such as near schools, on college campuses, in Main Street retail environments, and in other similar places. They are especially effective near elementary schools where they raise small children by a few inches and make them more visible.



*Raised crosswalk  
(Credit: Toole Design Group)*

### CURB EXTENSIONS

Curb extensions extend the sidewalk or curb line out into the parking lane, which reduces the effective street width. Curb extensions significantly improve pedestrian crossings by reducing the pedestrian crossing distance, visually and physically narrowing the roadway, improving the ability of pedestrians and motorists to see each other, and reducing the time that pedestrians are in the street. Reducing street widths improves signal timing since pedestrians need less time to cross.

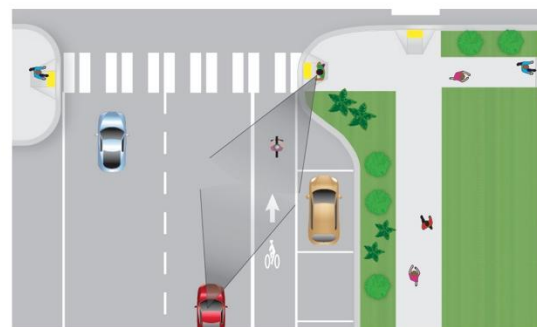

*Curb extensions  
(Credit: Michele Weisbart)*



Motorists typically travel more slowly at intersections or mid-block locations with curb extensions, as the restricted street width sends a visual cue to slow down. Turning speeds are lower at intersections with curb extensions (curb radii should be as tight as is practicable). Curb extensions also prevent motorists from parking too close to the intersection.

Curb extensions also provide additional space for two curb ramps and for level sidewalks where existing space is limited, increase the pedestrian waiting space, and provide additional space for pedestrian push button poles, street furnishings, plantings, bike parking and other amenities. A benefit for drivers is that extensions allow for better placement of signs (e.g., stop signs and signals).



*Example of curb extensions  
(Credit: Marcel Schmaedick)*

Curb extensions are generally only appropriate where there is an on-street parking lane. Where street width permits, a gently tapered curb extension can reduce crossing distance at an intersection along streets without on-street parking, without creating a hazard. Curb extensions must not extend into travel lanes or bicycle lanes.

Curb extensions can impact other aspects of roadway design and operation as follows:

- May impact street drainage and require catch basin relocation
- May impact underground utilities
- May require loss of curbside parking, though careful planning often mitigates this potential loss, for example by relocating curbside fire hydrants, where no parking is allowed, to a curb extension
- May complicate delivery access and garbage removal
- May impact street sweepers
- May affect the turning movements of larger vehicles such as school buses and large fire trucks

#### ALL-PEDESTRIAN PHASES

Exclusive pedestrian phases (i.e. pedestrian ‘scrambles’) may be used where turning vehicles conflict with very high pedestrian volumes and pedestrian crossing distances are short. Although pedestrians can cross in any direction during the pedestrian phase, pedestrians typically have to wait for both vehicle phases before they get the walk signal again. This creates delay for pedestrians travelling straight, but can be mitigated by allowing pedestrians continuing along the same direction to get a WALK signal during the green signal phase and while turns are prohibited for traffic. Diagonal crosswalk markings are consistent with 2009 MUTCD Chapter 3B.18.



*Proposed all-pedestrian phase and diagonal crosswalk markings  
(Credit: City of Lauderdale-By-The-Sea)*

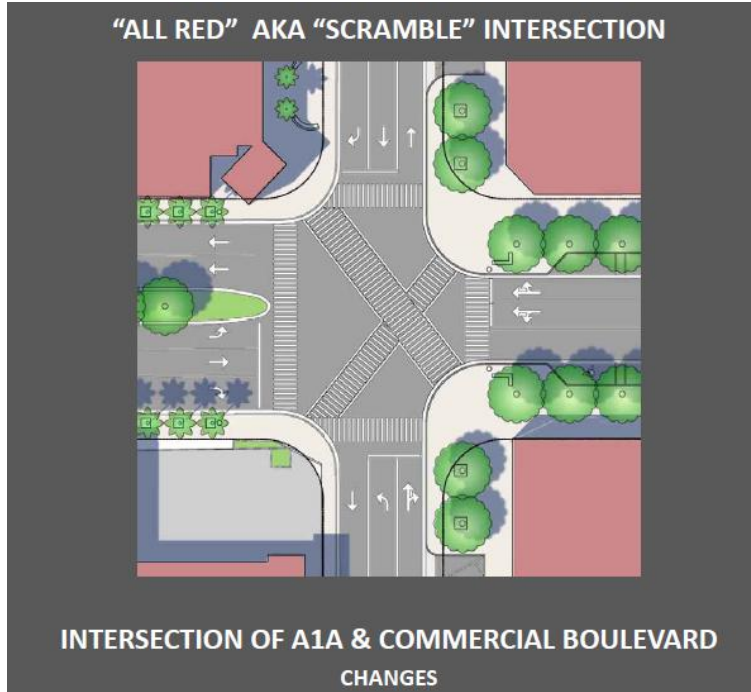

*Proposed all-pedestrian phase and diagonal crosswalk markings  
(Credit: City of Lauderdale-By-The-Sea)*



SIGNS

Signs can provide important information to improve road safety by letting people know what to expect, so they can react and behave appropriately. Sign use and placement should be done judiciously, as overuse breeds noncompliance and disrespect. Too many signs create visual clutter.

Regulatory signs, such as STOP, YIELD, or turn restrictions, require driver actions and can be enforced. Warning signs provide information, especially to motorists and pedestrians unfamiliar with an area.



*Pedestrian warning sign (MUTCD W11-2) with diagonal downward pointing arrow*



*Advance pedestrian warning sign with distance plaque (Credit: Kimley-Horn and Associates, Inc.)*

Advance pedestrian warning signs or pedestrian warning signs with distance supplemental plaques should be used where pedestrian crossings may not be expected by motorists, especially if there are many motorists who are unfamiliar with the area. The fluorescent yellow/green (FYG) color is designated specifically for pedestrian, bicycle, and school warning signs (Section 2A.10 of the 2009 MUTCD) and should be used for new and replacement installations. This bright color attracts the attention of drivers.

Sign R1-5 should be used in conjunction with advance yield lines, as described below. Sign R1-6 may be used on median islands, where they will be more visible to motorists than signs placed on the side of the street, especially where there is on-street parking.

Since Florida is a “yield” state, local jurisdictions should use R1-5, R1-5a, and R1-6 signs. It should be noted that *Florida State Statute 316* recognizes that the act of yielding may include stopping.

All signs should be periodically checked to make sure that they are in good condition, free from graffiti, reflective at night, and continue to serve a purpose.

All sign installations need to comply with the provisions of the MUTCD.



### ADVANCED YIELD/STOP LINES

Stop lines are solid white lines 12 to 24 inches wide, extending across all approach lanes to indicate where vehicles must stop in compliance with a stop sign or signal. Advance stop lines reduce vehicle encroachment into the crosswalk and improve drivers' view of pedestrians. At signalized intersections a stop line is typically set back between 4 and 6 feet.

At uncontrolled crossings of multi-lane roads, advance yield lines can be an effective tool for preventing multiple threat vehicle and pedestrian collisions. Section 3B.16 of the MUTCD specifies placing advanced yield markings 20 to 50 feet in advance of crosswalks, depending upon location-specific variables such as vehicle speeds, traffic control, street width, on-street parking, potential for visual confusion, nearby land uses with vulnerable populations, and demand for queuing space. Thirty feet is the preferred setback for effectiveness at many locations. This setback allows a pedestrian to see if a car in the second (or third) lane is stopping after a driver in the first lane has stopped.

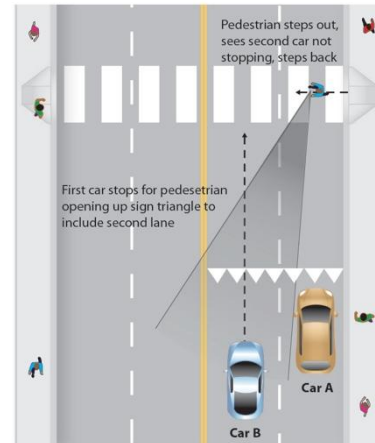

*Advanced yield markings  
 (Credit: Michele Weisbart)*

### LIGHTING

Lighting is important to include at all pedestrian crossing locations for the comfort and safety of the road users. Lighting should be present at all marked crossing locations. Lighting provides cues to drivers to expect pedestrians earlier.

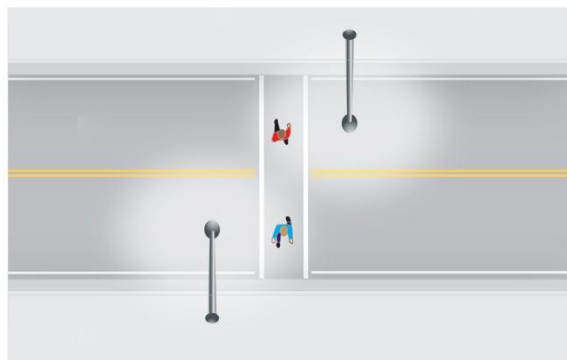

*Proper placement of crosswalk illumination  
 (Credit: Michele Weisbart)*

FHWA HT-08-053, *The Information Report on Lighting Design for Mid-block Crosswalks*, found that a vertical illumination of 20 lux in front of the crosswalk, measured at a height of 5 feet from the road surface, provided adequate detection distances in most circumstances. Although the research was constrained to mid-block placements of crosswalks, the report includes a brief discussion of considerations in lighting crosswalks co-located with intersections. The same principle applies at intersections. Illumination just in front of crosswalks creates optimal visibility of pedestrians.

Other good guidance on crosswalk lighting levels comes from the Illuminating Engineering Society of North America (IESNA) intersection guidance to illuminate pedestrians in the

crosswalk to vehicles (see the image below image). Crosswalk lighting should provide color contrast from standard roadway lighting.

**Table 8.1 Recommended Illumination by Street Type**

Functional Classification	Average Maintained Illumination at Pavement by Pedestrian Area Classification [FC]		
	High	Medium	Low
Major / Major (boulevard)	3.4 fc	2.6 fc	1.8 fc
Major / Collector (boulevard/avenue)	2.9 fc	2.2 fc	1.5 fc
Major / Local (avenue)	2.6 fc	2.0 fc	1.3 fc
Collector / Collector (avenue)	2.4 fc	1.8 fc	1.2 fc
Collector / Local (street)	2.1 fc	1.6 fc	1.0 fc
Local / Local (street)	1.8 fc	1.4 fc	0.8 fc

FC stands for "foot candle" and is defined as the amount of illuminance on a 1 square foot surface of which there is uniformly distributed flux of one lumen. ANSI-IESNA RP-8-00, *Roadway Lighting*, p. 15

### RECTANGULAR RAPID FLASHING BEACON (RRFB)

The RRFB uses rectangular-shaped high-intensity LED-based indications, flashes rapidly in a wig-wag "flickering" flash pattern, and is mounted immediately between the crossing sign and the sign's supplemental arrow plaque.



*Rectangular rapid flashing beacon (RRFB) crossing safety device with median refuge (Credit: Kimley-Horn and Associates, Inc.)*

The FHWA Office of Transportation Operations has reviewed available data and considers the RRFB to be highly successful for the applications tested (uncontrolled crosswalks). The RRFB offers significant potential safety and cost benefits because it achieves very high rates of compliance at a very low cost compared to other more restrictive devices such as full mid-block signalization. The components of the RRFB are not proprietary and can be assembled by any jurisdiction with off-the-shelf hardware. The FHWA believes that the RRFB has a low risk of safety or operational concerns. However, because proliferation of RRFBs in the roadway environment to the point that they become ubiquitous could decrease their effectiveness, use of RRFBs should be limited to locations with the most critical safety concerns, such as pedestrian and school crosswalks at uncontrolled locations, as tested in the experimentation.



The RRFB has received Interim Approval via FHWA’s “Interim Approval for Optional Use of Rectangular Rapid Flashing Beacons” (IA-11) dated July 16, 2008.

**PEDESTRIAN HYBRID BEACON**

A pedestrian hybrid beacon is used to warn and control traffic at an unsignalized location so as to help pedestrians cross a street or highway at a marked crosswalk.

A pedestrian hybrid beacon can be used at a location that does not meet traffic signal warrants or at a location that meets traffic signal warrants but a decision has been made to not install a traffic control signal. A minimum number of 20 pedestrians per hour is needed to warrant installation. This is substantially less than the 93 minimum needed for a signal installation.

If beacons are used, they should be placed in conjunction with signs, crosswalks, and advanced yield lines to warn and control traffic at locations where pedestrians enter or cross a street or highway. A pedestrian hybrid beacon should only be installed at a marked crosswalk.

Installations should be performed according to the MUTCD Chapter 4F, “Pedestrian Hybrid Beacons.”

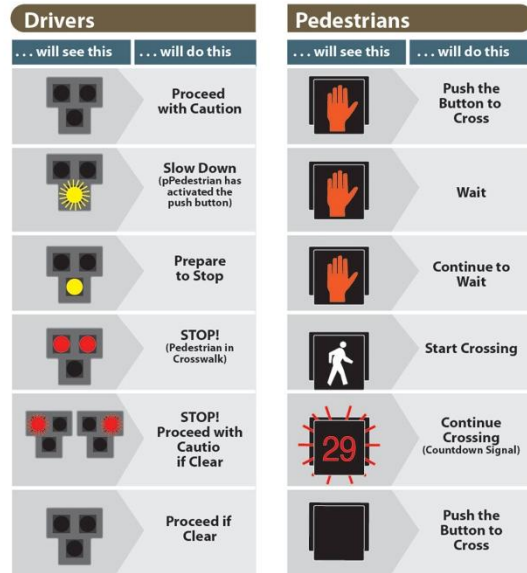

*Pedestrian hybrid beacon phases  
(Credit: Michele Weisbart)*

PEDESTRIAN TOOLBOX FOR RAILROAD CROSSINGS

Pedestrian crossings of railroad tracks apply a special set of tools. The following are the primary tools to apply.

- Pedestrian gates
- Channelization of pedestrians through gates and across tracks
- Warning flashers
- Signs
- Audible signals

More details can be found in the MUTCD.

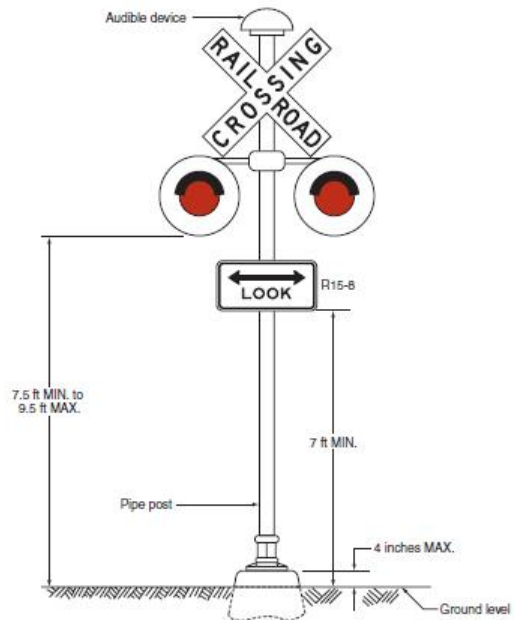

Flashing-light signal assembly for pedestrian railroad crossing  
 (Source: 2009 MUTCD Figure 8C.4)

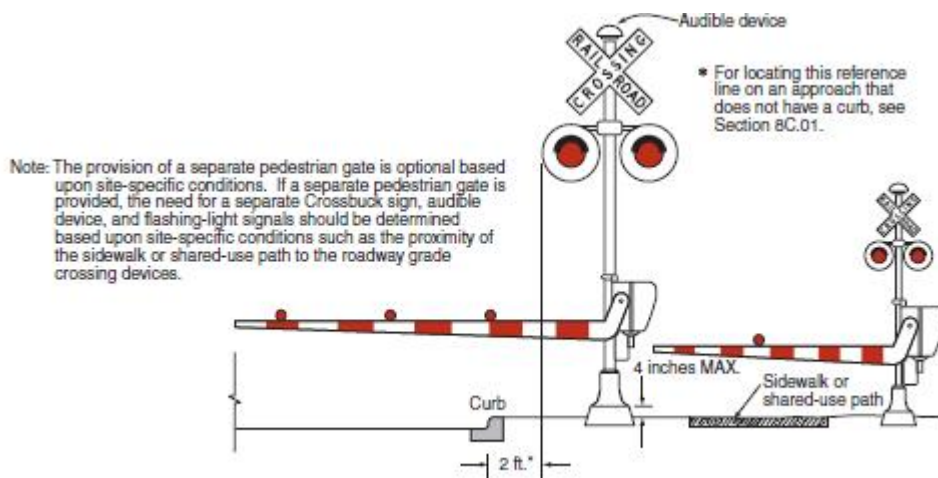

Separate pedestrian gate at a railroad crossing  
 (Source: 2009 MUTCD Figure 8C.6)



## 9. BIKEWAY DESIGN

INTRODUCTION.....	1
Bicycling For All Ages and Reasons .....	1
ESSENTIAL PRINCIPLES OF BIKEWAY DESIGN .....	2
PLANNING FOR A RANGE OF BIKEWAY USERS .....	2
Characteristics of Bicyclists and The Bicycle Vehicle .....	3
Bicyclist Skill Level .....	3
BIKEWAY TYPES AND DESIGNS .....	4
Bike Lanes .....	6
Buffered Bike Lanes.....	8
Raised Bike Lanes .....	9
Green Bike Lanes.....	10
Contra-Flow Bike Lanes .....	11
Shared Bus and Bike Lanes .....	12
Cycle Tracks.....	13
Shared Use Paths .....	16
Shared Roadways .....	18
Advisory Bike Lanes.....	19
Bicycle Boulevards.....	20
Shared Lane Markings (Sharrows) .....	23
Wide Outside Lanes.....	24
Undesignated Lane (Urban Shoulder).....	25
Paved Shoulders.....	26
Bike Route Wayfinding .....	27
INTEGRATING WITH THE STREET SYSTEM.....	28
INTERSECTIONS.....	29
Bikeway Markings at Intersections .....	30
Bicycle Signal Heads .....	30
Bicycle Signal Detection.....	31
Bicycle Countdowns (Countdown-To-Green).....	31
Leading Bicycle Intervals.....	31
Bike Boxes .....	32



Two-Stage Turn Queue Boxes.....32

BICYCLE PARKING .....33

MAINTENANCE.....34

LEGAL STATUS.....34

IMPLEMENTATION .....34

    Resurfacing .....35

    Utility Work.....36

    Redevelopment.....36

    Paved Shoulders.....37

ADDITIONAL RESOURCES .....37



*(Credit: Kimley-Horn and Associates, Inc.)*

## INTRODUCTION

Since the bicycle is a non-motorized vehicle, it is the cleanest and greenest form of vehicular transportation. The bicycle is human-powered. This simple fact should be integrated in concept throughout the essential principles, planning, design, and construction of bikeways.

Bicycle transportation is active transportation. Therefore, traveling by bicycle is not only environmentally-friendly, it promotes healthy living. Bicycle transportation helps individuals address many modern public health concerns including obesity, stress, and anxiety disorders.

Today, bicycling use is on the rise in the United States and crash rates have decreased over time through proven education, encouragement, and engineering techniques. However, bicyclists are still vulnerable road users who experience fatality rates significantly higher than the general mix of road users. According to research conducted by the Portland Bureau of Transportation, most bicyclists that use on-road bicycle facilities are classified as “strong and fearless” and are generally comfortable operating a bicycle intermixed with high traffic volumes and fast speeds. Most bicyclists prefer local streets with slow vehicular speeds, which tends to limit the number of destinations that they can comfortably reach given the current disconnected street network prevalent in most developed areas. Therefore, great progress is still ahead of us through creating truly bicycle-friendly infrastructure for all user types that enhances comfort, directness, accessibility, and safe traffic surroundings.

### BICYCLING FOR ALL AGES AND REASONS

Bicycling occurs at all ages, in all places, among all income groups, and for all kinds of reasons. Apart from its use for daily, functional journeys, the bicycle also plays a major role in recreational activities. Recreational bicycling is not just for fun; recreational bicycling should be given a high priority for public health reasons.



*Bicyclist on A1A, Fort Lauderdale  
 (Credit: Luisa Fernanda Arbeláez)*



*Young bicyclists leaving school  
 (Credit: Kimley-Horn and Associates, Inc.)*



Bicycle facilities and attractive surroundings are essential for people on bicycling trips. If these bicycle facilities are close to home, they improve the livability and hence the quality of the living environment.

## ESSENTIAL PRINCIPLES OF BIKEWAY DESIGN

The following principles inform the bikeway facility guidelines for Broward County and its local jurisdictions established in this chapter.

- Bicyclists should have safe, convenient, and comfortable access to all destinations.
- Every street is a bicycle street, regardless of whether a designated bicycle facility or bicycle route is present.
- Street design should accommodate all types, levels, and ages of bicyclists.
- Bicyclists should be separated from pedestrians, except under special circumstances such as shared-use pathways or shared-space streets.
- Bikeway facilities should take into account vehicle speeds and volumes, with
  - Shared use on low volume, low-speed roads.
  - Separation on higher volume, higher-speeds roads.
- Bikeway treatments should provide clear guidance to enhance safety for all users.
- Since most bicycle trips are short, a complete network of designated bikeways has a grid spacing of roughly ½ mile.



*Florida law requires 3 feet of passing separation  
(Credit: Kimley-Horn and Associates, Inc.)*

## PLANNING FOR A RANGE OF BIKEWAY USERS



*Plan bicycle facilities for various skill levels  
(Credit: Dan Burden)*

Many early bikeway designs assumed that bicyclists resemble pedestrians in their behavior. This led to undesirable situations, including bicyclists being underserved by inadequate facilities, pedestrians resenting bicyclists in their space, and motorists being confused by bicyclists entering and leaving the traffic stream in unpredictable ways. Only under special circumstances (e.g., on shared-use paths less than 14 feet in width or shared-space streets) should bicyclists and pedestrians share the same space.



## CHARACTERISTICS OF BICYCLISTS AND THE BICYCLE VEHICLE

As stated in Florida Statute 316.2065, bicyclists operate a vehicle and are legitimate road users. However, they are slower and less visible than motor vehicles.

Bicyclists should be the primary design parameter in bikeway facilities. Bicycling requires both the physical and mental capacities of the bicyclist. The physical capacity is required to initiate the vehicle's movement and to keep it moving. Mental capacity, both consciously and subconsciously, is required to ride the bicycle safely. Conscious mental capacity is required to operate the vehicle within traffic within traffic flow. Subconscious mental capacity is required to steer the bicycle, keep balance, and ride within a straight line.

*"Inadequate cycling lanes and sidewalks. I can often get part-way, but certain key stretches remain dangerous and eliminate the whole route."*

- Broward County Complete Streets (survey respondent)

In addition, the perceived dangers of bicycling tend to limit its ability to attract new riders as a transportation mode in many urban areas. The perceived dangers of bicycling on busy streets within the general public is one reason why enhanced bicycle facilities and going beyond the minimums will likely be necessary to attract a significant mode shift to bicycling.

## BICYCLIST SKILL LEVEL

Bicyclist skill level also provides a wide variety of speeds and expected behaviors. Several systems of bicyclist classification are used within the bicycle planning and engineering professions. These classifications can be helpful in understanding the characteristics and infrastructure preferences of different cyclists. However, these classifications may change in type or proportion over time as infrastructure and culture evolve. Bicycle infrastructure should use planning and designing options, from shared roadways to separate facilities, to accommodate as many user types as possible and to provide a comfortable experience for the greatest number of cyclists.

A classification system developed by the City of Portland, Oregon, provides the following bicycle user types:

- **Strong and Fearless.** Bicyclists who will ride anywhere regardless of roadway conditions. These bicyclists can ride faster than other user types, prefer direct routes,



*Proficient bicycle riders  
(Credit: Kimley-Horn and Associates, Inc.)*



and will typically choose roadways, even if shared with vehicles, over separate bicycle facilities such as shared-use paths. This bicyclist type comprises a very low percentage of the population.

- **Enthusied and Confident.** This group encompasses intermediate bicyclists who are mostly comfortable riding on all types of bicycle facilities but will usually prefer low traffic streets, bike lanes, or separate paths when available. They may deviate from a more direct route in favor of a preferred facility type. This group includes commuters, utilitarian cyclists, and recreational riders, and probably represents less than 10 percent of the population.
- **Interested but Concerned.** This user type makes up the bulk (likely between half and two-thirds) of the cycling or potential cycling population. They are cyclists who typically ride only on low traffic streets or paths under favorable conditions and weather. They perceive traffic and safety as significant barriers towards increased use of cycling. These cyclists may become “Enthusied and Confident” with encouragement, education, and experience.
- **No Way, No How.** People in this category are not cyclists; they perceive severe safety issues with riding in traffic and will never ride a bicycle in traffic under any circumstances. But some may eventually give cycling a second look and may progress to the user types above if better facilities are provided. This group likely comprises something between a quarter and a third of the population.

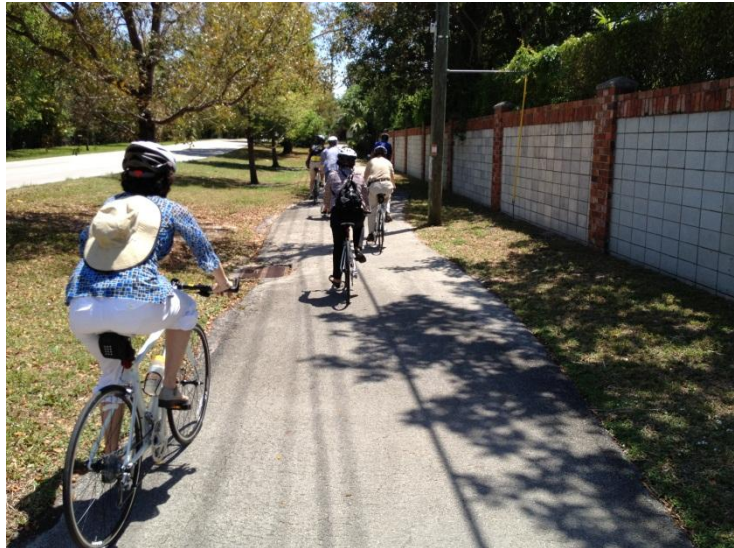

*Less-experienced bicycle riders prefer paths  
 (Credit: Kimley-Horn and Associates, Inc.)*

Of particular interest to the discussion of bicyclist skill level are children. Children riding on their own or with their parents may not travel as fast as their adult counterparts but still require access to key destinations in their community, such as schools, convenience stores, and recreational facilities. Residential streets with low motor vehicle speeds linked with shared-use paths and busier streets with well-defined pavement markings between bicycles and motor vehicles can accommodate children without encouraging them to ride in the travel lanes of major arterials.

## BIKEWAY TYPES AND DESIGNS

A designated bikeway network provides a system of facilities that offers enhancement, guidance, and/or priority to bicyclists over other roadways in the network. However, it is



important to remember that all streets in an urbanized area should safely and comfortably accommodate bicyclists, regardless of whether the street is designated as a bikeway. Several general types of bikeways are listed in this section with no implied order of preference.

In Florida, local jurisdictions should follow minimum width and geometric criteria in the Florida Manual of Uniform Minimum Standards (Florida Greenbook), or follow proper procedures for exemptions and experiments. It should be noted that the Florida Greenbook contains *minimums*. Local jurisdictions should not interpret this to mean *exact dimension*. In many circumstances, exceeding these minimums provides for a more desirable bicycling environment.

It should be noted that many of the bikeway facility types and geometric criteria established in this manual that go beyond minimum standards found in the Florida Greenbook have been implemented and evaluated in other metropolitan areas, and found to be successful from a safety, mobility, and encouragement perspective. These bikeway facility types are found in several planning and engineering guidebooks such as the National Association of City Transportation Officials (NACTO) *Urban Bikeway Design Guide* and the Institute of Transportation Engineers (ITE) *Designing Walkable Urban Thoroughfares: A Context Sensitive Approach*. In particular the NACTO *Urban Bikeway Design Guide* is intended to help practitioners make good decisions about urban bikeway design. The treatments outlined in the guide are based on real-world experience in some of the most bicycle friendly cities and have been selected for inclusion in the Guide because of their utility in helping local jurisdictions meet their goals related to bicycle transportation.

Many signs and pavement markings are available for use by planners and designers for bikeways as designated in the Federal Highway Administration (FHWA) *Manual on Uniform Traffic Control Devices* (MUTCD). Signs are referenced in this section by the acronym MUTCD and their MUTCD sign designation number for easy reference. Designers will find detailed design information including sign size and sign placement in the latest version of the MUTCD available online.

The Florida Department of Transportation (FDOT) provides designers with criteria for bicycle symbol markings and striping in *FDOT Standard Index 17347*. The *FDOT Plans Preparation Manual* (PPM) Chapter 8 provides guidance for bicycle facility design on the State Highway System (SHS).



*Bicycle lane pavement marking symbol  
 (Credit: Kimley-Horn and Associates, Inc.)*



## BIKE LANES



*Bicyclist using a bike lane with an R3-17 sign  
(Credit: Kimley-Horn and Associates, Inc.)*

A bike lane is that portion of the roadway that has been designated by striping and pavement markings for the preferential or exclusive use of bicyclists. Bike lanes should also be signed with the MUTCD R3-17 sign. (Note: The MUTCD now considers the R3-17 sign optional. This should not be interpreted as “not required.” Instead, designers have flexibility for the use and spacing of the R3-17 sign. In general, most urban bike lanes should include R3-17 signs. Factors that should be present for not providing the R3-17 signs are in situations of extreme sign clutter, in downtown districts where the sign would block pedestrian clear width, and in situations where dense, natural landscaping would block the

visibility and effectiveness of the sign and would detract from the natural beauty of the landscape).

### Advantages of Bike Lanes

- Bike lanes enable bicyclists to position themselves where they will be visible to motorists.
- Bike lanes facilitate predictable behavior and movements between bicyclists and motorists.
- Bike lanes encourage bicyclists to ride on the traveled way rather than the sidewalk.
- Bike lanes encourage bicyclists to ride in the direction of traffic.
- Bike lanes enable bicyclists to ride at their preferred speed without interference from prevailing road traffic conditions.
- Bike lanes enable bicyclists to ride at a constant speed (which minimizes energy loss), especially when traffic in the adjacent travel lanes speeds up or slows down (stop-and-go).

Motorists are prohibited from using bike lanes for driving and parking, but may use them for emergency avoidance maneuvers or breakdowns. Bike lanes are one-way facilities that carry bicycle traffic in the same direction as adjacent motor-vehicle traffic (one exception are contra-flow bike lanes, which are discussed later in this chapter).



Bike lanes may also have enhanced treatments, which are also addressed in subsequent sub-sections of this chapter. In general, the information presented in the Bike Lanes sub-section of this chapter refers to conventional bike lanes most commonly found in engineering manuals and design criteria.

Bike lanes are appropriate on arterial boulevards, avenues, and collectors. Bike lanes may also be provided on rural roads where there is high bicycle use. Bike lanes are generally not recommended on local streets with relatively low traffic volumes and speeds, where a shared roadway is the appropriate facility. Although there is no exact criteria, NACTO guidance states that bike lanes are most helpful on streets with greater than 3,000 motor vehicle average daily traffic and streets with a posted speed limit of 25 MPH or higher. Bike lanes may be used on other streets where bicycle travel and demand is substantial, such as within parks. Where on-street parking is provided, bike lanes are generally striped on the left side of the parking lane.

The following geometric design criteria are established for bike lanes.

- Preferred bike lane width (rideable surface) – 6 feet; absolute minimum width – 4 feet (the preferred dimensions should be used unless other street elements have been reduced to their minimum dimensions)
- Absolute minimum bike lane width adjacent to on-street parking – 5 feet (unless there is a marked buffer between the bike lane and on-street parking; where on-street parking is permitted, delineating the bike lane with two stripes, one on the street side and one on the parking side, is preferable to a single stripe)
- The desirable bike lane width adjacent to a guardrail or other physical barrier is 2 feet wider than otherwise in order to provide a minimum shy distance from the barrier
- Gutter seams, drainage inlets, and utility covers should be flush with the pavement and oriented to prevent conflicts with bicycle tires.
- Streets with high volumes of traffic and/or higher speeds need wider bike lanes (6 feet to 8 feet) than those with less traffic or slow speeds.
- Bike lanes on one-way streets should generally be on the right side of the traveled way and should always be provided on both legs of a one-way couplet. The bike lane may be placed on the left of a one-way street if it decreases the number of conflicts (e.g., those caused by heavy bus traffic or parking) and if bicyclists can safely and conveniently transition in and out of the bike lane. If sufficient width exists, the bike lanes can be striped on both sides of a one-way street.

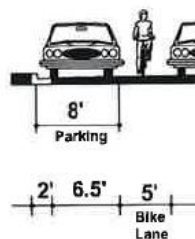
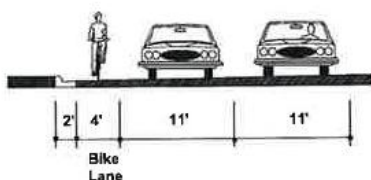

*Bike lane width minimums*

*(Source: Broward County Final Report on Alternative Roadway Design Guidelines)*



## BUFFERED BIKE LANES

Buffered bike lanes are conventional bike lanes paired with a designated buffer space separating the bicycle lane from the adjacent motor vehicle travel lane and/or parking lane. A buffered bike lane is optional for all bike lane facilities per MUTCD guidance for buffered preferential lanes found in 2009 MUTCD Section 3D-01.

According to *Evaluation of Innovative Bicycle Facilities: SW Broadway Cycle Track & SW Stark/Oak Street Buffered Bike Lanes* (Portland State University, Center for Transportation Studies, 2011), nine in ten bicyclists preferred a buffered bike lane to a conventional bike lane, seven in ten bicyclists indicated they would go out of their way to ride on a buffered bike lane over a conventional bike lane, and bicyclists indicate they feel lower risk of being “doored” in the buffered bike lanes when adjacent to on-street parking.

Buffered bike lanes provide the following advantages when compared to conventional bike lanes.

- Provides greater shy distance between bicyclists and motor vehicles.
- Provides space for faster moving bicyclists to pass slower moving bicyclists without having to encroach into the motor vehicle travel lane.
- Provides a greater space for bicycling without making the bike lane appear so wide that it might be mistaken for a travel lane or a parking lane.
- Appeals to a wider range of bicyclists and encourages bicycling.



*Buffered bike lane*

(Source: NACTO Urban Bikeway Design Guide)

Buffered bike lanes can be considered anywhere a standard bike lane is being considered. Although there is no standard criterion for when buffered bike lanes are required, in general buffered bike lanes should be provided on streets with high travel speeds, high volumes, high percentage of trucks or buses, and streets with extra space within the traveled way.

The buffer should be marked with a wide solid single white line along both edges of the buffer space. The buffer should be at least 2 feet in width, with diagonal hatching used if the buffer is 3 feet in width or greater. Consider dashing the inside buffer boundary where cars are expected to cross, such as adjacent to on-street parking. The combined width of the buffer and bike lane should be considered the “bike lane width”. Where buffers are used, bike lanes can be narrower because the shy distance function is assumed by the buffer. For example, a 4-foot bike lane and a 3-foot buffer could be provided adjacent to on-street parking since the “bike lane width” would be considered 7 feet. For a parking side buffer, parking T’s are acceptable to mark between a parking lane and the buffer.



## RAISED BIKE LANES

Bike lanes are typically an integral portion of the traveled way and are delineated from motor vehicle lanes with painted stripes. Although some bicyclists ride on these facilities comfortably, others prefer more separation. Raised bike lanes incorporate the convenience of riding on the street with some physical separation. This is accomplished by elevating the bicycle lane surface 2 to 4 inches above street level, while providing a traversable curb to separate the bikeway from the adjacent motor vehicle travel lane.

### Advantages of Raised Bike Lanes

- Motorists know they are straying from the travel way when they feel the slight bump created by the traversable curb.
- The traversable curb allows motorists to make turns into and out of driveways.
- The traversable curb allows cyclists to enter or leave the bike lane (e.g., for turning left or overtaking another cyclist).
- The raised bike lane drains towards the centerline, leaving it clear of debris and puddles.
- Novice bicyclists are more likely to ride in the bike lane, leaving the sidewalk for pedestrians.

Raised bike lanes can be constructed at little additional expense for new roads. Retrofitting streets with raised bike lanes is more costly; it is best to integrate raised bike lanes into a larger project to remodel the street due to drainage reconstruction. Special maintenance procedures may be needed to keep raised bike lanes swept. There is no restriction on the use of raised bike lanes in FHWA guidance as long as an appropriately designed traversable curb is used and all other MUTCD guidance is followed.

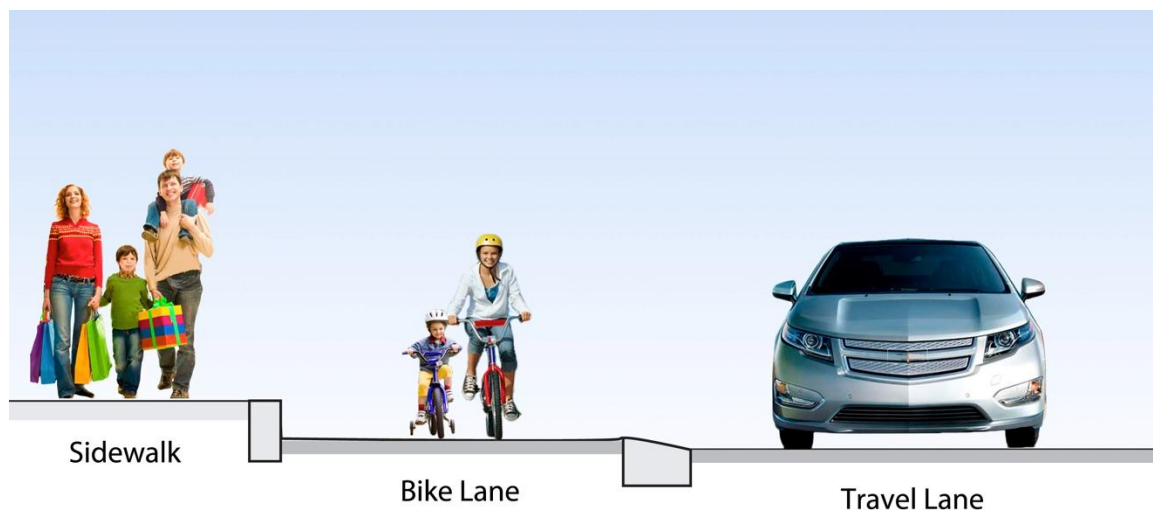

*Raised bike lanes (Credit: Michele Weisbart)*



## GREEN BIKE LANES

The Federal Highway Administration (FHWA) has issued an Interim Approval (IA-14) for the optional use of green colored pavement in designated bike lanes and in extensions of designated bike lanes through intersections and other traffic conflict areas. Green colored pavement may be installed within bicycle lanes as a supplement to the other pavement markings that are required for the designation of a bicycle lane.

FDOT has requested and received approval from FHWA for the use of green colored pavement in locations consistent with the FHWA's Interim Approval memorandum for state roadways. According to FDOT, the effectiveness of green colored pavement for bike lanes is maximized if the treatment is used only where the path of bicyclists crosses the path of other road users and where road users should yield to bicyclists. A traffic conflict area may include locations where the bike lane crosses an exclusive right-turn lane, a channelized free-flow right-turn lane, an add lane situation, a drop lane situation, a path that crosses a high number of driveways, or adjacent to a dedicated bus bay. FDOT provides more information about the optional use of green colored pavement for bike lanes in the 2012 Plans Preparation Manual (PPM), Chapter 8.4.2.2.

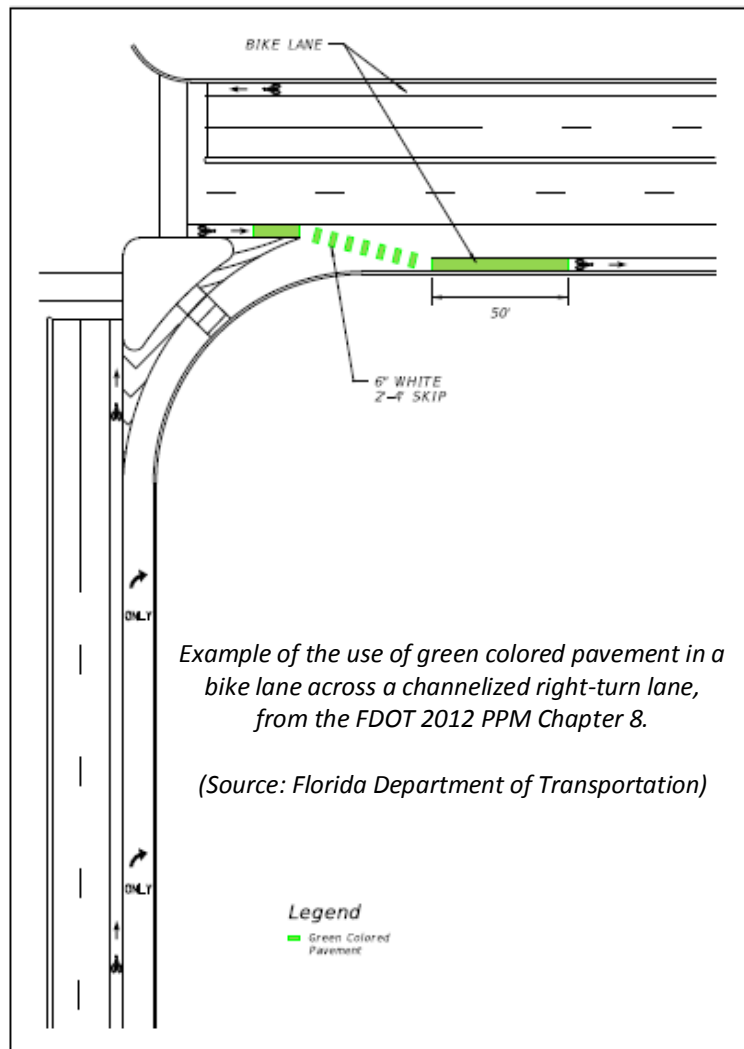

It should be noted that use of colored pavement within a bicycle lane increases the visibility of the facility and reinforces priority to bicyclists in conflict areas.

While a variety of colored treatments have been used, the FHWA approval is for green as the preferred color for bicycle facilities of this type in areas where conflicts or shared use is intended. Maintenance of color and surface condition are considerations. Traditional traffic paints and coatings can become slippery. Long life colored asphalt surfaces with good wet skid resistance should be considered.



## CONTRA-FLOW BIKE LANES

Contra-flow bike lanes are bike lanes designed to allow bicyclists to ride in the opposite direction of motor vehicle traffic. Contra-flow bike lanes convert a one-way traffic street into a two-way street for bicycles only (one direction for motor vehicles and bikes, and the other direction for motor vehicles).

Contra-flow bike lanes must be separated from the opposing direction of travel with double yellow center lane striping. Contra-flow bike lanes can be implemented at the present time without the need for experimentation if signs and pavement markings that are MUTCD-compliant are used.

Care must be exercised within the design process because the contra-flow design introduces new design challenges and may introduce new conflict points at intersections and driveways as motorists may not expect on-coming bicyclists. Intersection traffic controls including signal design modifications will be required to control the contra-flow bike lane.

Contra-flow bike lanes provide the following benefits.

- Provides a connectivity, accessibility, and travel time advantage for bicyclists on one-way streets.
- Reduces dangerous one-way bicycling by formalizing the contra-flow bicycle travel.
- Decreases sidewalk riding along one-way streets.



*Contra-flow bike lane*  
(Source: NACTO Urban Bikeway Design Guide)

### Typical Applications for Contra-Flow Bike Lanes

- Streets where bicyclists are already riding the wrong way.
- Streets where alternate routes require excessive out-of-direction travel.
- Streets where alternate routes include incomplete streets or uncomfortable streets for bicycling.
- Streets that could provide two-way connections between bicycle facilities.
- Streets that are low-speed and low-volume.
- Where space is provided, designated bike lanes should be provided on both sides. When there is no room for a with-flow bike lane, shared-lane markings (sharrows) should be used to guide with-flow bicyclists.
- If sufficient space exists, a buffered contra-flow bike lane design should be utilized.



## SHARED BUS AND BIKE LANES

In most instances, bicycles and buses can share the available road space. On routes heavily traveled by both bicyclists and buses, separation can reduce conflicts (stopped buses hinder bicycle movement and slower moving bicycles hinder buses). Ideally, shared bus and bike lanes should be 13 feet to 15 feet wide to allow passing by both buses and bicyclists.

Separate bus lanes and bike lanes should be considered to reduce conflicts between passengers and bicyclists, with the bus lane at the curbside. Buses will be passing bicyclists on the right, but the fewer merging and turning movements reduce overall conflicts.

Shared bus and bike lanes should be considered on roadways where bus rapid transit (BRT) improvements are desired, such as dedicated bus lanes, but not enough space exists to provide a bus lane and a bike lane.



*Simulation of a shared bus and bike lane adjacent to on-street parking  
(Source: San Diego Association of Governments)*



## CYCLE TRACKS

Cycle tracks, also known as protected bike lanes, are specially designed bikeways separated from the parallel motor vehicle travel lanes by a protective barrier. The barrier may be a physical barrier, such as a concrete curb, a line of parked cars, or landscaping, or a physical buffer that motor vehicles cannot cross, which may include traffic separators or plastic delineators. Cycle tracks are effective in attracting users who are concerned about conflicts with motorized traffic. Cycle tracks can be well suited to downtown areas where they minimize traffic conflicts with pedestrians.



*One-way cycle track (Credit: Dan Burden)*

Streets selected for cycle tracks should have minimal pedestrian crossings and driveways. They should also have minimal loading/unloading activity and other street activity.

There is no MUTCD restriction on the use of cycle tracks if signs and pavement markings that are compliant with the MUTCD are used. Cycle tracks should be designed to minimize conflicts with street activities as well as with pedestrians and driveways. Cycle tracks can be provided on new facilities, but they require more width than other types of bikeways. They are best suited for existing streets where surplus width is available; the combined width of the cycle track and the barrier is more or less the width of a travel lane. The area to be used by bicycles should be designed with adequate width for street sweeping to ensure that debris will not accumulate. Cycle tracks tend to work most effectively where there are few uncontrolled crossing points with unexpected traffic conflicts.

Cycle track concerns include visibility, treatment at intersections, uncontrolled midblock driveways and crossings, wrong-way bicycle traffic, and difficulty accessing or exiting the facility at midblock locations. There is some controversy regarding the comparative safety of cycle tracks. Recent studies have concluded that cycle tracks are as safe as other treatments when high usage is expected and when measures such as separate signal phases for right-turning motor vehicle and through cyclists, and left-turning cyclists and through motor vehicles, are deployed to regulate crossing traffic. Cycle tracks may be one-way or two-way.

- One-way cycle tracks
- Two-way cycle tracks



In addition, cycle tracks may be at varying levels of vertical separation.

- At the street level
- At the sidewalk level (raised cycle track)
- At an intermediate level (raised cycle track)

Note that a one-way cycle track at an intermediate level separated from motor vehicles by a traversable curb is the same as a raised bike lane presented earlier in this section.

### One-Way Cycle Tracks

- One-way protected cycle tracks are typically at street level and use a variety of methods for physical protection from motor vehicle traffic including curbs, medians, plastic traffic separators, and on-street parking.
- One-way protected cycle tracks, like conventional bike lanes, are essentially a type of preferential use lane as defined by the MUTCD in Section 2G.01.
- Like bike lanes, the desired width of a one-way protected cycle track at street level should be at least 6 feet. In areas of high bicycle volumes, the desired width should be greater. The design of the protective barrier or buffer should dictate the absolute minimum width. For example, if a flush striped buffer of 2 feet is provided between the cycle track and an adjacent on-street parking lane, then the minimum cycle track width could be as narrow as 4 feet, since the cycle track plus the buffer would create 6 feet of “bike lane width” space.



*One-way cycle track with on-street parking as the buffer from the motor vehicle travel lanes.  
Note the use of “parking T’s” to designate the on-street parking spaces.  
(Source: NACTO Urban Bikeway Design Guide)*



### Two-Way Cycle Tracks

- Two-way cycle tracks are physically separated cycle tracks that allow bicycle movement in both directions on one side of the road.
- While sharing some of the same design characteristics as one-way cycle tracks, additional considerations at driveway and intersections are required.
- Two-way cycle tracks may be configured as a protected cycle track at street level with a barrier or on-street parking to provide separation. They may also be configured as a raised cycle track at sidewalk level or at an intermediate level to provide vertical separation from motor vehicle traffic.
- If at the sidewalk level, a curb or median separates the cycle track from motor vehicle traffic, while different pavement color or texture separates the cycle track from the sidewalk.
- One of the typical applications for a two-way cycle track is when there is not enough room for a one-way cycle track on both sides of the street.
- Another typical application is where considerably more (or all) destinations and/or bicycle demand is located on one side of the street.



*Two-way cycle track  
(Credit: Kimley-Horn and Associates, Inc.)*

### Raised Cycle Tracks

- Raised cycle tracks are one-way or two-way bicycle facilities that are vertically separated from motor vehicle traffic.
- Raised cycle tracks may be separated from motor vehicle traffic by a curb, or they may be separated by a furnishing zone or landscaping zone.
- At intersections, the raised cycle track can be dropped and merged onto the street, or it can be maintained at sidewalk level where bicyclists cross with pedestrians, possibly with a dedicated bicycle signal.
- When a one-way raised cycle track at an intermediate level separated from motor vehicles by a traversable curb is provided, this is the same as a raised bike lane presented earlier in this section.



## SHARED USE PATHS

Shared use paths are facilities separated from motor vehicle traffic by an open space or barrier. Shared use paths can be either within a roadway right-of-way or within an independent right-of-way. Examples of independent rights-of-way that can include shared use paths include waterways, utility corridors, and rail lines. Bicyclists, pedestrians, joggers, and skaters often use shared use paths, such as canals. They are often elements of a community trail plan. Shared use paths may also be integrated into the street network with new subdivisions as described in Chapter 4, “Street Networks and Classifications.”

Shared use paths provide the following advantages.

- Shared use paths are attractive to bicyclists who are uncomfortable riding or are unable to ride in mixed traffic.
- Shared use paths are often part of designated bike route systems.
- Shared use paths in independent rights-of-way can provide travel time savings for bicyclists by making connections that would otherwise be significantly longer through the roadway network.



*Example of a shared-use path: Pompano Airpark Path  
 (Credit: Kimley-Horn and Associates, Inc.)*

The following geometric design criteria are established for shared use paths.

- Preferred shared use path width – 12 feet; absolute minimum path width – 8 feet (the preferred dimensions should be used unless right-of-way constraints dictate)
- A graded shoulder of 2 feet should be provided on each side of the shared use path.
- Wider pavement may be needed in high-use areas. Where significant numbers of pedestrians, bicyclists, skaters, and other users share the path, either wider pavement or separate walkways should be used to help to eliminate conflicts. A minimum width of 14 feet is typically recommended for separating users (two 4-foot lanes one in each direction for wheeled users, and a 6-foot space for pedestrians). Separation of modes on shared use paths can be implemented and signed with the MUTCD R9-7 sign.
- Shared use paths are not substitutes for on-road bicycle facilities. Many advanced bicyclists choose on-road bicycle facilities even when shared-use paths are provided within the same right-of-way.
- The intersections of shared-use paths with roads are of critical importance to the overall environment and safety experienced by users. Intersections should be designed with crossing safety treatments that assist path users to cross the road. Consistent with



FDOT PPM Chapter 8.3.2, curb ramps on shared-use paths should be the same width as the path itself to minimize conflicts between bicyclists and pedestrians. The trail crossing warning sign (MUTCD W11-15) should be used to warn motorists of the shared use path crossing location.

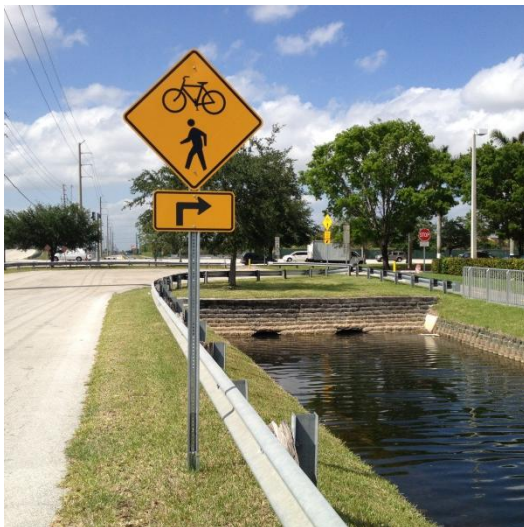

Examples of signage associated with shared-use paths  
(Credits: Kimley-Horn and Associates, Inc.)



## SHARED ROADWAYS

A shared roadway is a street in which bicyclists comfortably ride in the same travel lanes as other traffic because of the low-volume, low-speed characteristic of the roadway. Shared roadways as a bikeway type should not be confused with other shared situations, such as bicycle boulevards, shared lane markings (sharrows), or wide curb lanes, which are discussed later in this chapter.

A good example of shared roadways are most local residential neighborhood streets where motor vehicle traffic volume and traffic speeds are low enough that even novice bicyclists feel comfortable riding in the street.

Shared roadways are the most common bikeway type. There are no specific width standards for shared roadways. Most are fairly narrow; they are simply the streets as constructed. Under certain conditions, a narrow width may increase the viability of a shared roadway as a bikeway because it means that a motorist is forced to remain behind a bicyclist without attempting an overtaking maneuver if there is oncoming traffic. The suitability of a narrow lane or a wide lane for shared roadways is the subject of many factors, such as the intensity of bicycle traffic and the presence of on-street parking.

The suitability of a shared roadway decreases as motor vehicle traffic speeds and volumes increase. Many local streets carry excessive traffic volumes at speeds higher than they were designed to carry. These can function better as shared roadways if traffic speeds and volumes are reduced. For a local street to function acceptably for bicyclists as a shared roadway, traffic volumes should not be more than 3,000 to 5,000 vehicles per day, and speeds should be 25 mph or less. If traffic speeds and volumes exceed these thresholds, separated facilities (e.g., bike lanes) should be considered or traffic calming should be applied to reduce the vehicle speeds/volumes. Many traffic calming techniques can make these streets more amenable to bicycling while also solving other community goals related to livability.

Shared space streets are a type of shared roadway where speeds are very slow (rarely more than walking speed). Bicyclists, other wheeled users, motor vehicles, and pedestrians all share the same space. Shared space streets may support café seating, play areas, and other uses. More information on shared space streets can be found in Chapter 4, “Street Networks and Classifications,” Chapter 5, “Traveled Way Design,” Chapter 11, “Traffic Calming,” and Chapter 13, “Re-Placing Streets.”

### Centerline Removal

On low-volume, low-speed streets with one travel lane in each direction, removal of the centerline is one strategy to facilitate passing of bicyclists by motor vehicles. Motorists may be unwilling to cross over a centerline to pass a bicyclist, resulting in instances where motorists feel like they are stuck behind a slower moving bicyclist and attempt to pass the bicyclist too closely. Bicyclists in these situations may feel pressured to ride to the extreme far right or in



the gutter to allow motorists to pass. Removal of the centerline opens the entire traveled way for passing, and allows bicyclists to position themselves at a safe and comfortable distance from the curb or roadside obstacles. Lack of centerlines is also a traffic calming technique, as drivers tend to drive slower without the visible separation from oncoming traffic.

The MUTCD mandates centerline stripes on urban streets with average daily traffic (ADT) of 6,000 or more; most neighborhood streets suitable for shared roadway bicycle facilities are well below that threshold and could be candidates for centerline removal.

### ADVISORY BIKE LANES

In some cases, local governments may wish to stripe bike lanes on narrow local streets for which centerline removal is recommended or no centerline exists. If motor vehicles will need to encroach into the bike lane to pass oncoming vehicles, the bike lanes should be striped with white “skip stripes” instead of solid white edge striping. In this case, these dashed bike lanes are called advisory bike lanes. Motor vehicles should only enter the advisory bike lane for the purpose of going around an oncoming vehicle or to enter a parking stall (when applicable).

An example of an advisory bike lane has been implemented on East 14<sup>th</sup> Street in Minneapolis.

Advisory bike lanes are currently an experimental treatment for which FHWA experiments are in progress. Local jurisdictions wishing to implement advisory bike lanes should follow the FHWA experimentation process for new traffic control devices outlined in Chapter 1, “Introduction.”



*Before (left) and after (right) views of the advisory bike lanes on East 14<sup>th</sup> Street in Minneapolis. The after condition aerial on the right shows the centerline removal and the placement of dashed advisory bike lanes. Note that the street still accommodates two-way traffic. Motorists only encroach into the advisory bike lanes when passing an oncoming vehicle or to access the on-street parking.*

*(Photo Source: Google Maps and Google Street View, Accessed June 19, 2012)*



## BICYCLE BOULEVARDS



*Bicycle boulevard: Portland, OR  
(Credit: Ryan Snyder)*

A bicycle boulevard is an enhanced shared roadway; it is a local street that has been modified to prioritize through bicycle traffic but discourage through motor vehicle traffic. Bicycle boulevards can be thought of as bicycle arterials.

To create a bicycle boulevard, a local street is modified to function as a prioritized through street for bicyclists while maintaining local access for automobiles. This is done by adding traffic calming devices to reduce motor vehicle speeds and through trips, and installing traffic control devices that limit conflicts between motorists and bicyclists and give priority to through bicyclist movement.

One key advantage of bicycle boulevards is that they attract bicyclists who do not feel comfortable on busy streets and prefer to ride on lower traffic streets. Bicycle travel on local streets is generally compatible with local land uses (e.g., residential and some retail). Residents who want slower traffic on neighborhood streets often like measures that support bicycle boulevards. By reducing traffic and improving crossings, bicycle boulevards also improve conditions for pedestrians. Successful bicycle boulevard implementation requires careful planning with residents and businesses to ensure acceptance.



*Traffic circles allow for landscaping opportunities  
(Credit: Ryan Snyder)*

### Elements of a Bicycle Boulevard

A successful bike boulevard includes the following design elements.

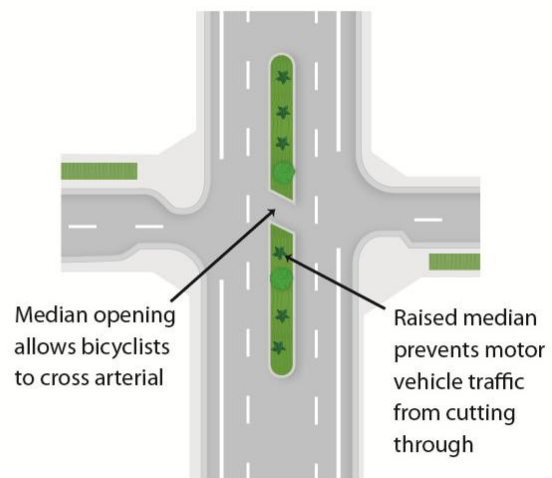
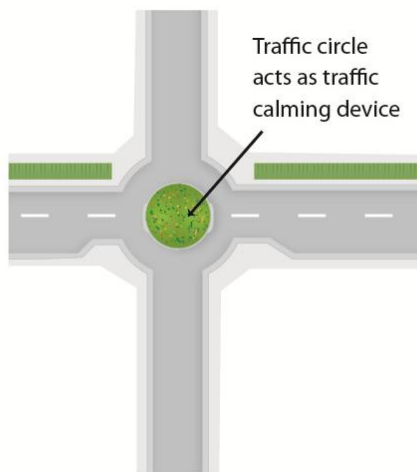
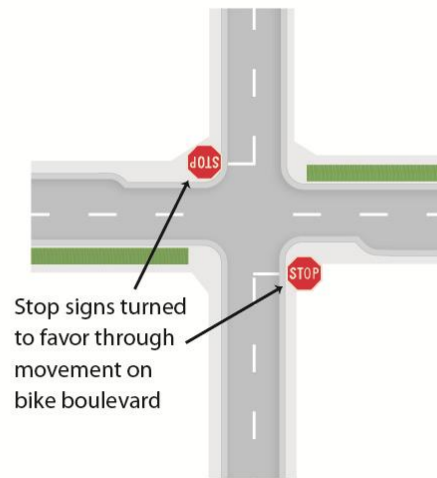
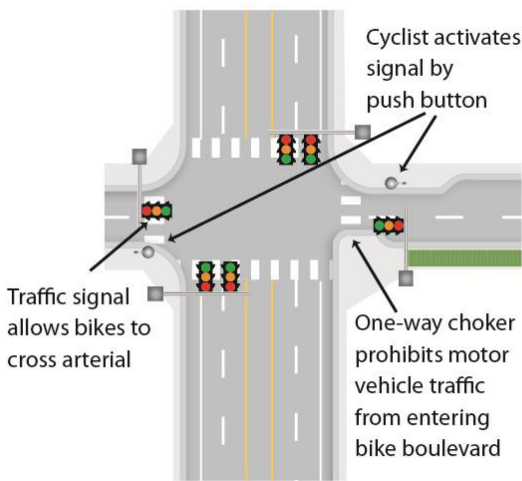

*Components of bicycle boulevards (Credit: Michele Weisbart)*

- Selecting a direct and continuous street, rather than a circuitous route that winds through neighborhoods. Bike boulevards work best on a street grid. If any traffic diversion will likely result from the bike boulevard, selecting streets that have parallel higher-level streets can prevent unpopular diversion to other residential streets.
- Placing motor vehicle traffic diverters at key intersections to reduce through motor vehicle traffic (diverters are designed to allow through bicyclist movement)
- Turning stop signs towards intersecting streets, so bicyclists can ride with few interruptions



- Replacing stop-controlled intersections with mini-circles and mini-roundabouts to reduce the number of stops cyclists have to make
- Placing traffic-calming devices to lower motor vehicle traffic speeds
- Placing wayfinding and other signs or markings to route cyclists to key destinations, to guide cyclists through difficult situations, and to alert motorists of the presence of bicyclists
- Where the bicycle boulevard crosses high-speed or high-volume streets, providing crossing improvements such as the following.
  - Signals, where a traffic study has shown that a signal will be safe and effective. To ensure that bicyclists can activate the signal, loop detection should be installed in the pavement where bicyclists ride.
  - Roundabouts where appropriate.
  - Median refuges wide enough to provide a refuge (8 feet minimum) and with an opening wide enough to allow bicyclists to pass through (approximately 6 feet). The design should allow bicyclists to see the travel lanes they must cross.

Bicycle boulevards in and of themselves are not traffic control devices, so there is no overall restriction on their use from the FHWA. Bicycle boulevards can be implemented at the present time without the need for experimentation if signs, pavement markings, and traffic control devices that are compliant with the MUTCD are used.



## SHARED LANE MARKINGS (SHARROWS)

Shared-lane markings (also commonly called “sharrows”) may be used as an additional pavement marking treatment for shared roadways. Sharrows can serve a number of purposes.

- Sharrows remind bicyclists to ride farther from parked cars to prevent “dooring” collisions.
- Sharrows make motorists aware of the expectation to find bicycles sharing the travel lane.
- Sharrows recommend proper lateral spacing guidance for bicyclists.
- Sharrows show bicyclists the correct direction of travel.

The 2009 MUTCD outlines guidance for sharrows in Section 9C.07. In addition, FDOT Standard Index 17347 provides guidance for the geometric design criteria and spacing of sharrows. As shared lane markings are relatively new, guidance on application of sharrows will likely evolve. Shared lane markings should not be considered a substitute for bike lanes, cycle tracks, or other designated bicycle facilities where these types of facilities are otherwise warranted or space permits. Shared lane markings can be used as the standard element in the development of bicycle boulevards.

Shared lane markings may be accompanied by a “Bicycles May Use Full Lane” sign (MUTCD R4-11).

Placing the sharrow between vehicle tire tracks increases the life of the markings and decreases long-term maintenance costs.



*Sharrows pavement marking  
(Credit: Kimley-Horn and Associates, Inc.)*



*MUTCD R4-11 sign  
(Credit: Kimley-Horn and Associates, Inc.)*



## WIDE OUTSIDE LANES

On streets where bike lanes would be more appropriate but with insufficient width for bike lanes, wide outside lanes may be provided. This situation may occur on resurfacing projects where there are physical constraints and all other options, such as narrowing travel lanes, have been pursued. Wide outside lanes are not particularly attractive to most bicyclists; they simply allow a motorized vehicle to pass bicyclists within a travel lane without encroaching into an adjacent lane, if bicyclists are riding far enough to the right.

Wide curb lanes may also encourage higher motor vehicle speed, which is contrary to the design principles of this manual. Wide lanes should never be used on local residential streets. A 14- to 15-foot wide lane allows a passenger car to pass a bicyclist in the same lane. The sharrow pavement marking may be considered for use at the appropriate lateral placement within a wide outside lane. However, a “Bicycles May Use Full Lane” sign (MUTCD R4-11) should never be used for a wide outside lane. Widths of 16 feet or greater encourage the undesirable operation of two motor vehicles in one lane. In this situation, a designated bike lane should be striped.

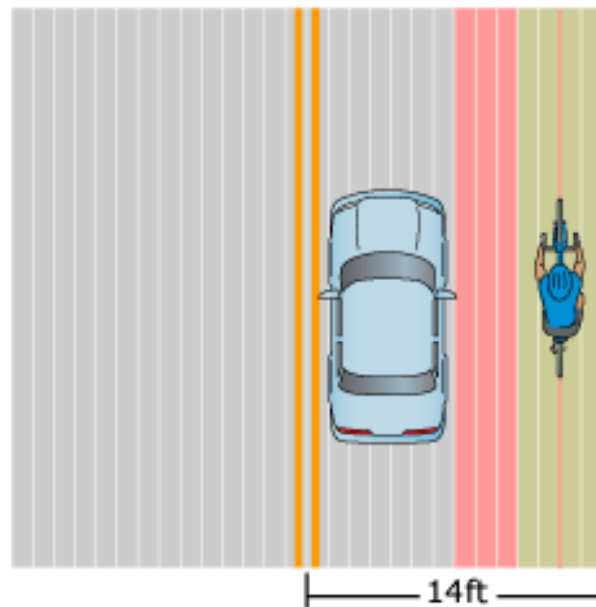

*Wide outside lane  
(Credit: Florida Bicycle Association)*



### UNDESIGNATED LANE (URBAN SHOULDER)

On streets where bike lanes would be more appropriate but with insufficient width for bike lanes, an undesignated lane (urban shoulder) may be provided as an alternative to the wide outside lane.

If provided, a minimum 3-foot wide smooth surface should be provided between the lip of the gutter pan and edge line stripe. This minimum width enables bicyclists to ride far enough from the curb to avoid debris and drainage grates and far enough from other vehicles to avoid conflicts. By riding away from the curb, bicyclists are more visible to motorists than when hugging the curb. Undesignated lanes have similar characteristics as wide outside lanes, but with the added benefit of an edge line striping between motor vehicles and bicyclists. However, it is likely that only the “strong and fearless” bicyclists feel comfortable in this undesignated space.



*Undesignated lane.  
Note the corner radius striping, which allows bicycles to enter the  
undesignated lane.*

*(Credit: Kimley-Horn and Associates, Inc.)*



## PAVED SHOULDERS

Paved shoulders accommodate bicycle travel on rural highways and country roads by providing a suitable area for bicycling and reducing conflicts with faster moving motor vehicles. Paved shoulders are only a rural bicycle facility. Paved shoulders in urban areas are signed and marked as bike lanes. Paved shoulders have similar characteristics as bike lanes, but are not designated through pavement marking symbols and signage.

Paved shoulders are provided on rural highways for a variety of safety, operational, and maintenance reasons. When providing paved shoulders, bicycle use should be assumed.

- A preferred width of 6 feet is recommended. This allows a bicyclist to ride far enough from the edge of pavement to avoid debris and far enough from passing vehicles to avoid conflicts.
- On rural roads with prevailing speeds over 45 mph, 8 feet is preferred.
- An absolute minimum width of 4 feet for a paved shoulder bicycle facility may be used under constraints.
- When rumble strips are provided on the paved shoulder, care should be exercised to ensure at least a minimum rideable surface of 4 feet is provided to the outside of the rumble strip. When designed properly, rumble strips can be a benefit to bicyclists using a paved shoulder by notifying motorists when they begin to encroach upon the shoulder. Since rumble strips are approximately 1.5 feet wide, and are typically offset from the edge line striping by approximately 0.5 feet, a paved shoulder with a rumble strip must be a minimum of 6 feet in total width to accommodate bicyclists within the outer 4 feet.



*Paved shoulder with Share-the-Road sign assembly  
(Credit: Kimley-Horn and Associates, Inc.)*



## BIKE ROUTE WAYFINDING

A bicycle route wayfinding system consists of comprehensive signing and/or pavement markings to guide bicyclists to their destinations along preferred bike routes. A bike route is a term used for planning purposes or to designate recommended bicycle transportation or recreation routes. A bike route is not a facility type. A bike route can be any bikeway type.

- Wayfinding signs are typically placed at decision points along bike routes.
- There are three general types of wayfinding signs.
  - Confirmation signs indicate to bicyclists that they are on a designated bikeway. Confirmation signs can include destinations and distance/time but do not include arrows. Confirmation signs have an added benefit of making motorists aware of the bicycle route.
  - Turn signs indicate where a bikeway turns from one street to another street. Turn signs include arrows, and may include destinations and distance/time. Turn signs should be placed on the near-side of intersections and may be supplemented with pavement markings.
  - Decision signs mark the junction of two or more bike routes. Decision signs inform bicyclists of the designated bike route to access key destinations. Decision signs include destinations and arrows. Distances and travel times are recommended but are optional.



*Bicycle route turn signage at a path entrance to Tradewinds Park  
(Credit: Kimley-Horn and Associates, Inc.)*



*Numbered bicycle route signage at a turn location. Note that if the arrow turn plaque were removed, this would be a confirmation sign.*

*(Credit: Kimley-Horn and Associates, Inc.)*



*Bicycle route destination signage at a decision point  
(Credit: Kimley-Horn and Associates, Inc.)*



## INTEGRATING WITH THE STREET SYSTEM

Most bikeways are part of the street; therefore, well-connected street systems are very conducive to bicycling, especially those with a fine-meshed network of low-volume, low-speed streets suitable for shared roadways. In less well-connected street systems, where wide streets carry the bulk of traffic, bicyclists need supplementary facilities, such as short sections of paths and bridges, to connect otherwise unconnected streets.

There are no hard and fast rules for when a specific type of bikeway should be used, but some general principles guide selection. As a general rule, as traffic volumes and speeds increase, greater separation from motor vehicle traffic is desirable. Other factors to consider are user type (more children or recreational cyclists may warrant greater separation), adjacent land uses (multiple driveways may cause conflicts with shared-use paths), available right-of-way (separated facilities require greater width), and costs.

As a general rule, designated bicycle facilities (e.g., bike lanes and cycle tracks) should be provided on all major streets (avenues and boulevards), as these roads generally offer the greatest level of directness and connectivity in the network, and are typically where destinations are located. There are occasions when it is infeasible or impractical to provide bikeways on a busy street, or the street does not serve the mobility and access needs of bicyclists. The following guidelines should be used to determine if it is more appropriate to provide facilities on a parallel local street.

- Conditions exist such that it is not economically or environmentally feasible to provide adequate bicycle facilities on the street.
- The street does not provide adequate access to destination points within reasonable walking distances, or separated bikeways on the street would not be considered safe.
- The parallel route provides continuity and convenient access to destinations served by the street.
- Costs to improve the parallel route are no greater than costs to improve the street.
- If any of these factors are met, bicyclists may actually prefer the parallel local street facility in that it may offer a higher level of comfort (bicycle boulevards are based on this approach).

Off-street paths can also be used to provide transportation in corridors otherwise not served by the street system, such as along utility corridors and canals, through parks, on abandoned railroad tracks, or along active railroad rights-of-way. While paths offer the safety and scenic advantages of separation from traffic, they must also offer frequent connections to the street system and to destinations such as residential areas, employment sites, shopping, and schools. Street crossings must be well designed with measures such as signals or median refuge islands.



## INTERSECTIONS

Intersections are junctions at which different modes of transportation meet and facilities overlap. A well-designed intersection facilitates the interchange between bicyclists, pedestrians, motorists, and transit so traffic flows in a safe and efficient manner. Designs for intersections with bicycle facilities should reduce conflicts between bicyclists (and other vulnerable road users) and vehicles by heightening visibility, denoting a clear right-of-way, and ensuring that the various users are aware of each other. Intersection treatments can resolve both queuing and merging maneuvers for bicyclists, and are often coordinated with timed or specialized signals.

Chapter 6, “Intersection Design,” provides general principles of geometric design; all these recommendations will benefit cyclists. The configuration of a safe intersection for bicyclists may include additional elements such as color, signs, medians, signal detection, and pavement markings. Intersection design should take into consideration existing and anticipated bicyclist, pedestrian, and motorist movements. In all cases, the degree of mixing or separation between bicyclists and other modes is intended to reduce the risk of crashes and increase bicyclist comfort. The level of treatment required for bicyclists at an intersection will depend on the bicycle facility type used, whether bicycle facilities are intersecting, the adjacent street function, and the adjacent land use.

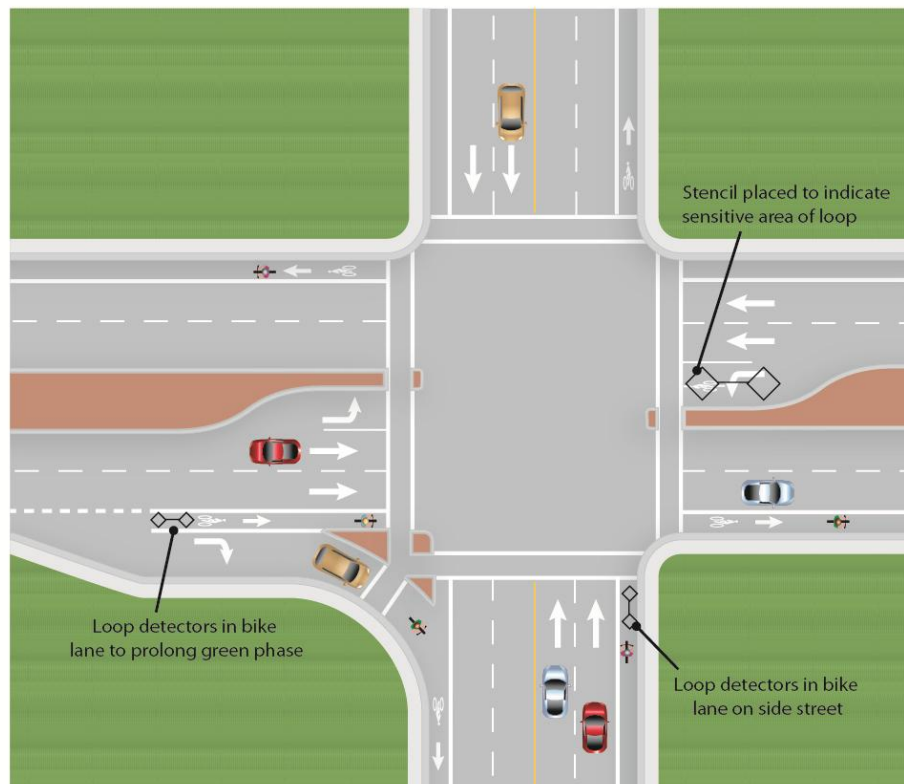

*Bikeway markings at intersections (Credit: Michele Weisbart)*



## BIKEWAY MARKINGS AT INTERSECTIONS

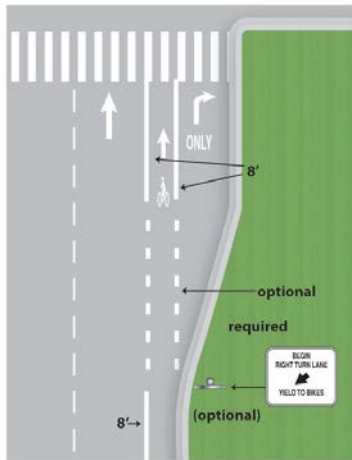

*Bike lane markings at intersections with right-turn lanes  
(Credit: Michele Weisbart)*

Continuing marked bicycle facilities at intersections (up to the crosswalk) ensures that separation, guidance on proper positioning, and awareness by motorists are maintained through these potential conflict areas. The appropriate treatment for right-turn only lanes is to place a bike lane pocket (a.k.a. “keyhole lane”) between the right-turn lane and the rightmost through lane. The “Begin Right Turn Lane, Yield to Bikes” sign (MUTCD R4-4) sign may also be posted to indicate to motorists that they must yield to bicyclists crossing the taper of the right-turn only lane.

If a full bike lane pocket cannot be accommodated, a combined bicycle lane/right-turn lane can be installed that places a standard-width bike lane on the left side of a dedicated right-turn lane. A dashed strip delineates the space for bicyclists and motorists within the shared lane (this is another form of an “advisory bike lane” discussed earlier in the chapter). This treatment must include pavement markings and signs advising motorists and bicyclists of proper positioning within the lane. Regulatory signage should be provided stating that bicyclists are allowed to make a through movement from the right-turn lane.

Sharrows are another option for marking a bikeway through an intersection where a bike lane pocket cannot be accommodated.

## BICYCLE SIGNAL HEADS



*Bicycle signal head:  
Long Beach, CA  
(Credit: Charlie Gandy)*

Bicycle signal heads may be installed at signalized intersections to improve identified safety or operational problems for bicyclists. Bicycle signal heads provide guidance for bicyclists at intersections where bicyclists have different needs from other road users (e.g., bicycle-only movements and leading bicycle intervals) or to indicate separate bicycle signal phases and other bicycle-specific timing strategies. A bicycle signal should only be used in combination with an existing conventional or hybrid beacon. In the United States, bicycle signal heads typically use standard three-lens signal heads in green, yellow, and red with a stencil of a bicycle. Bicycle signal heads are currently experimental; local jurisdictions that wish to implement bicycle signal heads should follow the FHWA experimentation procedures outlined in Chapter 1,

“Introduction.” Bicycle traffic signal phasing with circular indications are approved for use by FHWA if a “Bike Signal” sign is mounted adjacent to the signal face.



## BICYCLE SIGNAL DETECTION

Bicycle detection is used at actuated traffic signals to alert the signal controller of bicycle crossing demand on a particular approach. Bicycle detection occurs either through the use of push buttons or by automated means (e.g., in-pavement loops, video, and microwave). Inductive loop vehicle detection at many signalized intersections is calibrated to the size or metallic mass of a vehicle, meaning that bicycles may often go undetected. The result is that bicyclists must either wait for a vehicle to arrive, dismount and push the pedestrian button (if available), or cross illegally. Loop sensitivity can be increased to detect bicycles.

Proper bicycle detection must accurately detect bicyclists (be sensitive to the mass and volume of a bicycle and its rider); and provide clear guidance to bicyclists on how to actuate detection (e.g., what button to push or where to stand).

Broward County Traffic Engineering Division (BCTED) is migrating toward video detection for traffic signals. BCTED staff has indicated that it is possible to set-up detection zones for bicyclists within the video detection system. Bicycle detection zones should be established as standard procedure for all transportation projects involving traffic signal work.



*Bicycle signal detection sign  
(Credit: Toole Design Group)*

## BICYCLE COUNTDOWNS (COUNTDOWN-TO-GREEN)

Near-side bicycle signals may incorporate a “countdown-to-green” display to provide information about how long until the green bicycle indication is shown, enabling riders to push off as soon as the light turns green, which improves visibility for bicyclists.

## LEADING BICYCLE INTERVALS

Based on the Leading Pedestrian Interval, a Leading Bicycle Interval (LBI) can be implemented in conjunction with a bicycle signal head. Under an LBI, bicyclists are given a green signal while the vehicular traffic is held at all red for several seconds, providing a head start for bicyclists to advance through the intersection. This treatment is particularly effective in locations where bicyclists are required to make a challenging merge or lane change (e.g., to access a left turn pocket) shortly after the intersection, as the LBI would give them sufficient time to make the merge before being overtaken by vehicular traffic. LBIs also generally increase bicyclist visibility to motorists when passing through the intersection after a red light. This treatment can be used to enhance a bike box.



## BIKE BOXES

A bike box is a designated area at the head of a traffic lane at a signalized intersection that provides bicyclists with a safe and visible way to queue during the red signal phase and helps facilitate left-turn movements when the bike box extends across all of the through lanes. Bike boxes are accompanied by advanced stop lines for motor vehicles and no-turn-on-red restrictions. Appropriate locations include:

- At signalized intersections with high volumes of bicycles and/or motor vehicles, especially those with frequent bicyclist left-turns and/or motorist right-turns.
- Where there may be right or left-turning conflicts between bicyclists and motorists.
- Where there is a desire to better accommodate left-turning bicycle traffic.
- Where a left turn is required to follow a designated bike route or bicycle boulevard, to access a shared-use path, or when the bicycle lane moves to the left side of the street.
- When the dominant motor vehicle traffic flows right and bicycle traffic continues through (such as at a Y intersection or access ramp).



*Bicycle box: Portland, OR  
(Credit: Ryan Snyder)*

Bike boxes are currently an experimental treatment for which FHWA experiments are in progress. Local jurisdictions wishing to implement bike boxes should follow the FHWA experimentation process for new traffic control devices outlined in Chapter 1, “Introduction.”

## TWO-STAGE TURN QUEUE BOXES

On right-side cycle tracks, bicyclists are often unable to merge into traffic to turn left due to physical separation. This makes the provision of two-stage left turns critical in ensuring these facilities are functional. The same principles for two-stage turns apply to both bike lanes and cycle tracks. While two-stage turns may increase bicyclist comfort in many locations, this configuration will typically result in higher average signal delay for bicyclists due to the need to receive two separate green signal indications (one for the through street, followed by one for the cross street) before proceeding.

Accommodating two-stage “delayed” left-turns via pavement markings and signal detection can be implemented at the present time according to FHWA guidance if signs and pavement markings that are compliant with the MUTCD are used.

## BICYCLE PARKING

Secure bicycle parking at likely destinations is an integral part of a bikeway network. On-street bicycle parking should be accommodated within the furniture zone of a sidewalk in downtown districts and urban centers. Secure bicycle parking may also be accommodated within the frontage zone if it does not block doorways, windows, or building access. Bicycle parking should also be provided at bus stops. Bicycle thefts are common and lack of secure parking is often cited as a reason people hesitate to ride a bicycle. The same consideration should be given to bicyclists as to motorists, who expect convenient and secure parking at all destinations. Bicycle parking should be located in well-lit, secure locations close to the main entrance of a building, no further from the entrance than the closest automobile parking space. Bicycle parking should not interfere with pedestrian movement.



*On-street bicycle parking in a building frontage zone near a decorative wall mural: Fort Lauderdale  
 (Credit: Kimley-Horn and Associates, Inc.)*

Bike racks along sidewalks should support the bicycle well (typically two points of contact with the frame), and make it easy to lock a U-shaped lock to the frame of the bike and the rack. Examples below show an “inverted U” rack and an art design rack that meet these functional criteria. Refer to the Association of Pedestrian and Bicycle Professionals (APBP) *Bike Parking Guidelines* for additional information.



*Inverted U Bike Rack  
 (Credit: Sky Yim)*



*Bicycle racks can double as public art: Los Angeles, CA  
 (Credit: Sky Yim)*



## MAINTENANCE

Maintenance is a critical part of safe and comfortable bicycle access. Two areas that are of particular importance to bicyclists are pavement quality and drainage grates. Rough surfaces, potholes, and imperfections, such as joints, can cause a rider to lose control and fall. Care must be taken to ensure that drainage grates are bicycle-safe; otherwise a bicycle wheel may fall into the slots of the grate, causing the cyclist to fall. The grate and inlet box must be flush with the adjacent surface. Inlets should be raised after a pavement overlay to the new surface. If this is not possible or practical, the new pavement should taper into drainage inlets so the inlet edge is not abrupt.

The most effective way to avoid drainage-grate problems is to eliminate them entirely with the use of inlets in the curb face. This may require more grates to handle bypass flow, but is the most bicycle-friendly design.

## LEGAL STATUS

As of the writing of the *Broward Complete Streets Guidelines*, a number of the designs discussed in this chapter, including advisory bike lanes, bike boxes, and bicycle signal heads, have not yet been adopted by the FHWA's MUTCD or AASHTO, and are therefore considered experimental treatments. However, these devices appear to be promising improvements in bicycle access and safety as they have been widely used in Europe and experimented with in several U.S. cities with positive results. All of the techniques and devices presented herein are discussed at length in the NACTO *Urban Bikeway Design Guide* and the reader is directed to consult the NACTO Guide for more detailed information including case studies and examples.

Every potential implementation condition is different and care must be exercised to follow sound planning and engineering principles for the use of these facilities. Any local jurisdiction wishing to use the treatments that do not specifically fall under MUTCD guidance should follow the appropriate experimental procedures as outlined by the FHWA's "Request for Experimentation" (RFE), which is summarized in Chapter 1, "Introduction."

## IMPLEMENTATION

Implementation of a bikeway network often requires an implementation plan. Some bikeways, such as paths, bicycle boulevards, and other innovative techniques described in this guide, will require a capital improvement project process, including identifying funding, a public and environmental review process, and plan preparation. Other bikeway improvements piggy-back onto planned construction, such as resurfacing, reconstruction, or utility work.



The majority of bikeway facilities are provided on streets in the form of shared roadways or bicycle lanes. Shared roadways usually require virtually no change to existing roadways, except for some directional signs, occasional markings, and minor changes in traffic control devices; removing unnecessary centerline stripes is a strategy that can be implemented after resurfacing projects. Striped bike lanes are implemented on existing roads through use of the strategies below.

## RESURFACING

The cost of striping bicycle lanes is negligible when incorporated with resurfacing, as this avoids the high cost of stripe removal; the fresh pavement provides a blank slate. Jurisdictions will need to anticipate opportunities and synchronize restriping plans with repaving and reconstruction plans. If new pavement is not anticipated in the near future, grinding out the old lane lines can still provide bike lanes.

There are three basic techniques for accommodating bike facilities:

- **Lane width narrowing.** Where all existing or planned travel lanes must be retained, travel lanes can be narrowed to provide space for bike lanes. Recent studies have indicated that the use of 10-foot travel lanes does not result in decreased safety in comparison with wider lanes for vehicle speeds up to 35 mph. Eleven-foot lanes can be used satisfactorily at higher speeds especially where trucks and buses frequently use these streets. However, where a choice between a 6-foot bike lane and an 11-foot travel lane must be made, it is usually preferable to have the 6-foot bike lane. Parking lanes can also be narrowed to 7 feet to create space for bike lanes on slow-speed (generally 25 MPH or less) streets. More information on lane width narrowing is provided in Chapter 15, “Retrofitting Suburbia.”
- **Road diets.** Reducing the number of travel lanes provides space for bicycle lanes. Many streets have more space for vehicular traffic than necessary. Some streets may require a traffic and/or environmental analysis to determine whether additional needs or impacts may be anticipated. The traditional road diet changes a four-lane undivided street to two travel lanes, a continuous left-turn lane (or median), and bike lanes. In other cases, a four-lane street can be reduced to a two-lane street without a center-turn lane if there are few left turns movements. One-way couplets are good lane-reduction candidates if they have more travel lanes in one direction than necessary for the traffic volumes. For example, a four-lane one-way street can be reduced to three lanes and a bike lane. Since only one bike lane is needed on a one-way street, removing a travel lane can free enough room for other features, such as on-street parking or wider sidewalks. Both legs of a couplet must be treated equally, so there is a bike lane in each direction. More information on road diets is provided in Chapter 15, “Retrofitting Suburbia.”

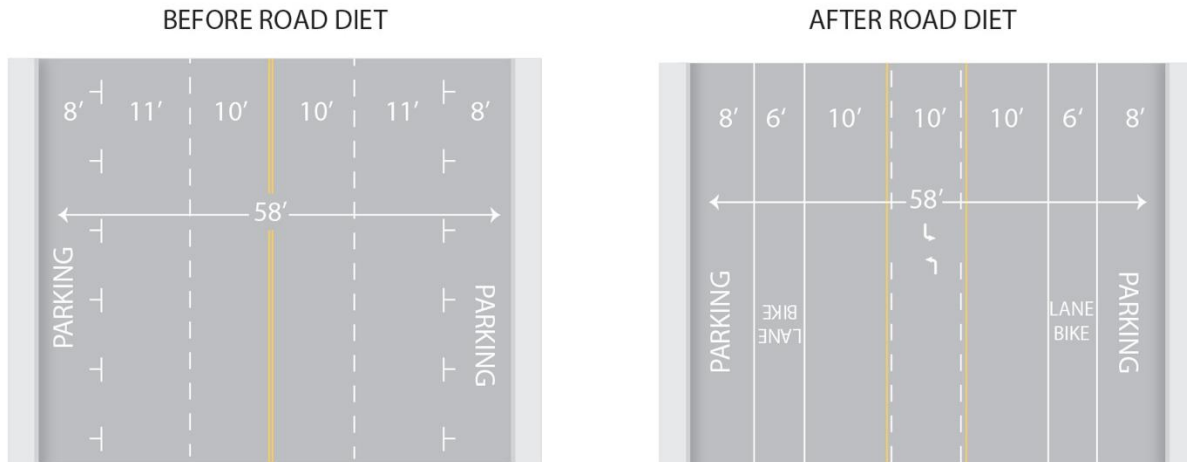

*Accommodating bicycle lanes with road diets (Credit: Michele Weisbart)*

- On-Street Parking Removal.** On-street parking is vital on certain streets (such as residential or traditional central business districts with little or no off-street parking); but other streets have allowable parking without a significant visible demand. In these cases, parking prohibition can be used to provide bike lanes with minimal public inconvenience. On-street parking removal should always be preceded by a district-wide parking study to ensure adequate shared parking is provided for local businesses and residences.

## UTILITY WORK

Utility work often requires reconstructing the street surface to complete restoration work. This provides opportunities to implement bike lanes and more complex bikeways such as bike boulevards, cycle tracks, or paths. It is necessary to provide plans for proper implementation and design of bikeway facilities prior to the utility work. It is equally necessary to ensure that existing bikeways are replaced where they exist prior to utility construction.

## REDEVELOPMENT

When streets are slated for reconstruction in conjunction with redevelopment, opportunities exist to integrate bicycle lanes or other facilities into the redevelopment plans.



## PAVED SHOULDERS

Adding paved shoulders to existing roads can be quite expensive if done as stand-alone capital improvement projects, especially if swale lines have to be moved, or if open drains are changed to enclosed drains. But paved shoulders can be added at little extra cost if they are incorporated into projects that already disturb the area beyond the pavement, such as laying utility lines or drainage work.

## ADDITIONAL RESOURCES

Federal Highway Administration (FHWA), *Manual on Uniform Traffic Control Devices for Streets and Highways* (MUTCD), 2009 Edition.

National Association of City Transportation Officials (NACTO), *Urban Bikeway Design Guide*, 2011.

American Association of State Highway Transportation Officials (AASHTO), *Guide for the Development of Bicycle Facilities*, 2012.

Florida Department of Transportation (FDOT), *2012 Plans Preparation Manual*, Chapter 8.

Florida Department of Transportation (FDOT), *Standard Index 17347*.

Florida Department of Transportation (FDOT) *Manual of Uniform Minimum Standards for Design, Construction, and Maintenance for Streets and Highways* (The Florida Greenbook), 2011.

Association of Pedestrian and Bicycle Professionals (APBP), *Bike Parking Guidelines*, 2<sup>nd</sup> Edition.



This page left blank intentionally.



## 10. TRANSIT ACCOMMODATIONS

INTRODUCTION.....	1
Broward County County-Wide Community Design Guidebook .....	1
FDOT District Four Transit Facilities Guidelines.....	2
ESSENTIAL PRINCIPLES OF DESIGNING STREETS FOR TRANSIT .....	3
OPTIMIZE ACCESS TO TRANSIT .....	4
BUS STOPS .....	5
Layout .....	5
Transit-Specific Streetscape Elements .....	6
BUS STOP PLACEMENT .....	7
SIGNAL TREATMENT.....	9
URBAN DESIGN .....	10
BICYCLE CONNECTIONS.....	10
BUS LANES .....	10
BUS BULBS .....	12
Characteristics.....	13
ACCOMODATING LIGHT RAIL, STREET CARS, and BRT.....	14



*(Credit: Kimley-Horn and Associates, Inc.)*



## INTRODUCTION

Public transit serves a vital transportation function for many people; it is their access to jobs, school, shopping, recreation, visiting friends and family, worship, and many other daily functions. Broward County Transit (BCT) and its Community Bus partners use the street network to serve these trip functions. For transit to provide optimal service, streets must accommodate transit vehicles as well as access to stops. Transit connects passengers to destinations and is an integral component of shaping future growth into a smarter, more sustainable form. Street design should also help transit support placemaking, which is discussed in more detail in Chapter 13, “Re-Placing Streets: Putting the Place Back in Streets.”



*On-board a Broward County Transit (BCT) bus  
 (Credit: Broward County Transit)*

This chapter provides design guidance for both transit stops and transit operating in the streets, including bus stop layout and placement and the use of bus bulbs and transit lanes. The chapter ends with a discussion of ways to accommodate light rail, street cars, and Bus Rapid Transit (BRT).

### BROWARD COUNTY COUNTY-WIDE COMMUNITY DESIGN GUIDEBOOK

The *Broward County County-Wide Community Design Guidebook* was prepared by Anthony Abbate Architect, PA and adopted by the Broward County Board of County Commissioners. The Community Design Guidebook (CDG) recommends design principles for transportation that integrate public transit into street design and urban form. The CDG recognizes that the character of an urban community is based upon its modes of transportation. Transit-specific considerations included in the transportation design principles are included below.

- The most effective way to influence the future urban form of a community or along a corridor within a community is to identify the modes of transit to be implemented.
- Without implementation of alternative transit modes the default design mode will continue to be the automobile.
- Design routes for multi-modal transportation with priority to transit vehicles, pedestrians, and bicycles.



- Serve the primary right to mobility through various modes including pedestrian and transit.
- Coordinate primary and secondary transit corridors in relation to planned land uses.
- Integrate art and design into the service infrastructure.
- Develop major transit corridors tied to land use.
- Design transit to encourage ridership and promote redevelopment.
  - High-quality, attractive, safe, comfortable, and convenient facilities promote transit use.
- Design transit facilities for people.
  - Provide a bench or a rail for resting.
  - Provide trash receptacles.
  - Integrate shading louvers to provide shade and increase protection from inclement weather.
  - Provide a means for displaying well-designed public information and advertising.

***“One can travel from here without a car, but it takes quite a walk to reach where a bus stops and then there is an interminable wait for the bus”***

- (Broward Complete Streets Guidelines public survey respondent)

#### FDOT DISTRICT FOUR TRANSIT FACILITIES GUIDELINES

Broward County is located within District Four of the Florida Department of Transportation (FDOT). District Four developed *Transit Facilities Guidelines* to provide a basis for development of transit facilities located within the jurisdiction of District Four and for engineers to interact with local agencies or private entities developing transit facilities. According to the Guidelines, it is the intention of District Four to facilitate the design process for transit facilities through the development of the guidelines. Project teams are encouraged to work with the FDOT District Four staff, Broward County Transit (BCT), the Broward Metropolitan Planning Organization (MPO), and local government transportation planners during the planning and design process for projects that affect transit facilities to ensure early consideration of transit needs and identification and resolution of design conflicts and decisions.



*BCT 95 Express Bus*  
(Credit: Broward County Transit)



## ESSENTIAL PRINCIPLES OF DESIGNING STREETS FOR TRANSIT

Public transit should be planned and designed as part of the street system. It should interface seamlessly with other modes, recognizing that successful transit depends on customers getting to the service via walking, bicycling, car, taxi, or paratransit. Transit should be planned following the following principles.

- On some streets, transit vehicles should have higher priority than private vehicles.
- The busiest transit lines should have designated bus lanes.
- Where ridership justifies, some streets, called transit hubs, may permit only buses or trains in the travelled way. These often also allow bicycles.
- Technology should be applied to increase average speeds of transit vehicles where appropriate through options such as transit signal priority (TSP) and bus queue jumpers.
- Transit stops should be easily accessible, with safe and convenient crossing opportunities.
- Transit stops should be active and appealing public spaces that attract people on a regular basis, at various times of day, and on all days of the week.
- Transit stops function as community destinations. The largest stops and stations should be designed to facilitate programming for a range of community activities and events.
- Transit stops should include infrastructure for passengers waiting to board such as real time traveler information systems, natural or artificial canopies (shelters), wayfinding signs, route maps, system maps, benches, and trash receptacles.
- Transit stops should provide space for a variety of amenities in commercial areas, to serve residents, shoppers, and commuters alike.
- Transit stops should be attractive and visible from a distance.
- Transit stop placement and traveled way design influences accessibility to transit and network operations, and influences travel behavior/mode choice.
- Zoning codes, local land use ordinances, and context sensitive design and solutions guidelines around transit stations should encourage walking and a mix of land uses (see Chapter 14, “Designing Land Use along Complete Streets”).
- Streets that connect neighborhoods to transit facilities should be especially attractive, comfortable, inviting, and safe for pedestrians and bicyclists.



*Old Town Transit Center in San Diego  
 (Credit: Kimley-Horn and Associates, Inc.)*



## OPTIMIZE ACCESS TO TRANSIT

The width and function of the pedestrian network influences safety and help achieve accessibility to the bus stop. The range of access to adjacent properties, from visual access to physical access on streets served by transit, are important design considerations. Bicycle-friendly streets do the same for those who access transit by bicycle.

Every transit trip also requires a safe and convenient street crossing at the transit stop. The demarcation of pedestrian, bicycle, transit, and vehicular use areas should be carefully considered to provide optimal access and exposure to the uses.

A disproportionately high number of pedestrian crossing crashes occur at transit stops. Every transit stop should be evaluated for its transit connection and crossing opportunities. If the crossing is deemed unsafe, mitigation can occur in two ways: a crossing should be provided at the existing stop, or the stop can be moved to a location with a safer crossing. For street crossing measures, see Chapter 8, "Pedestrian Crossings." Simply stated, there should not be transit stops without means to safely and conveniently cross the street.



*Bus approaching well-situated bus stop near enhanced crosswalk  
(Credit: National Complete Streets Coalition)*

But simply moving a stop is not always a service to transit users who may have to walk further to access their stop. Convenient access by passengers must remain at the forefront of all transit stop planning: eliminating stops because they are perceived as unsafe will not be satisfactory to riders who cannot walk very far. But eliminating or consolidating stops can be beneficial to transit operations and users by reducing the number of times a bus, streetcar, or light rail train has to stop. The

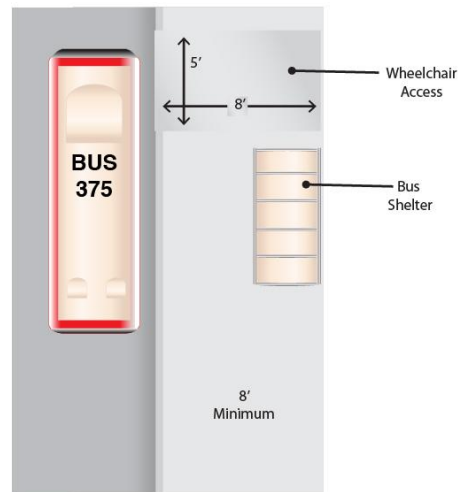

*ADA compliant bus stop  
(Credit: Michele Weisbart)*



trade-offs are added walking time for users but reduced transit operator delay, resulting in a shorter journey overall. For example, this might mean a two to three minute longer walk for some passengers but an eight to 10 minute shorter bus ride for all.

## BUS STOPS

The following sections provide guidance for designing bus stops.

### LAYOUT

A well placed and configured transit stop offers the following characteristics:

- Clearly defines the stop as a special place
- Provides a visual cue on where to wait for a transit vehicle
- Does not block the path of travel on the adjacent sidewalk
- Allows for ease of access between the sidewalk, the transit stop, and the transit vehicle



*Boarding a BCT bus  
(Credit: Broward County Transit)*

Layout guidelines include the following:

- Consolidate streetscape elements to create a clear waiting space and minimize obstructions between the sidewalk, waiting area, and boarding area
- Consider the use of special paving treatments or curb extensions (where there is on-street parking) to distinguish transit stops from the adjacent sidewalks
- Integrate transit stops with adjacent activity centers whenever possible to create active and safe places
- Avoid locating bus stops adjacent to driveways, curb cuts, and land uses that generate a large number of automobile trips (gas stations, drive-thru restaurants, etc.)



*Bus stop shelter  
(Credit: Sky Yim)*

Transit stops are required by the Americans with Disabilities Act (ADA) to be accessible. Specifically, ADA requires a clear loading area (minimum 5 feet



by 8 feet) perpendicular to the curb with a maximum 2 percent cross-slope to allow a transit vehicle to extend its lift to allow people with disabilities to board. The loading area should be located where the transit vehicle has its lift and be accessible directly from a transit shelter. The stop must also provide 30 by 40 inches of clear space within a shelter to accommodate wheelchairs. The greater use of low-floor transit vehicles may make this requirement moot; but it will still be necessary to provide enough room so wheelchair users can access the front doors.

### TRANSIT-SPECIFIC STREETScape ELEMENTS

The essential streetscape elements for transit infrastructure include signs, shelters, and benches.

**Benches** should be provided at transit stops as right of way permits.

**Shelters** keep waiting passengers out of the rain and sun and provide increased comfort and security. Shelters vary in size and design; standard shelters roof widths are 3 to 7 feet wide by 6 to 16 feet long. They include covered seating and sign panels that can be used for transit information. Shelters should

- Be provided at busy transit stops at transfer points
- Have electrical connections to power lighting and/or real-time transit information, or accommodate solar power
- Be set back from the front of the bus stop to allow for the bus to merge into travel lanes when the stop is located at the far side of an intersection or at a mid-block location. This setback is not required when the stop is located at the near side of the intersection or at a bus bulb.



*Transit shelter with bench and bicycle parking adjacent to park-and-ride lot, Pembroke Pines*

*(Credit: Kimley-Horn and Associates, Inc.)*



*Transit shelter with solar power*

*(Credit: Maribel Feliciano)*

Shelters should be located in a sidewalk's transit infrastructure area (furniture zone) so they don't conflict with the pedestrian zone. Shelters may be placed in the sidewalk's frontage zone provided that they do not block building entrances or the pedestrian zone.

Transit stops should also provide other amenities to make waiting for the next bus comfortable:



- Trash/recycling receptacles should be provided and maintained at most stops.
- Depending on headways and the number of passengers boarding and alighting, electronic “next bus” readouts can be used to inform passengers when to expect the next bus.
- Very busy bus stops and transit stations should include space for vendors to sell newspapers, magazines, flowers, and other goods to keep the stops lively.
- Rapid bus lines can include facilities that allow passengers to pay their fare before boarding the bus (sometimes called pre-boarding fare collection or off-vehicle fare collection). Along with wide doors on buses, this allows buses to reduce their travel time by reducing dwell time at stops.



*Pre-boarding fare collection, TransMilenio, Bogotá, Colombia  
(Credit: Stewart Robertson)*

## BUS STOP PLACEMENT

A bus stop’s optimal placement depends on the operational characteristics of both the roadway and the transit system. The placement of bus stops at the far side of signalized intersections is generally considered to be preferable to near side or mid-block locations. However, each location has its advantages and disadvantages, as shown in Table 10.1.



**Table 10.1 Bus Stop Placement Considerations**

Location	Advantage	Disadvantage
Near Side	<ul style="list-style-type: none"> <li>Minimizes interference when traffic is heavy on the far side of an intersection</li> <li>Provides an area for a bus to pull away from the curb and merge with traffic</li> <li>Minimizes the number of stops for buses</li> <li>Allows passengers to board and alight while the bus is stopped at a red light</li> <li>Allows passengers to board and alight without crossing the street if their destination is on the same side of the street. This is most important where one side of the street has an important destination, such as a school, shopping center, or employment center that generates more passenger demand than the far side.</li> </ul>	<ul style="list-style-type: none"> <li>Increases conflicts with right-turning vehicles</li> <li>Stopped buses may obscure curb-side traffic control devices and crossing pedestrians</li> <li>Obscures sight distances for vehicles crossing the intersection that are stopped to the right of the buses</li> <li>Decreases roadway capacity during peak periods due to buses queuing in through lanes near bus stops</li> <li>Decreases sight distance of on-coming traffic for pedestrians crossing intersections</li> <li>Can delay buses that arrive during the green signal phase and finish boarding during the red phase</li> <li>Less safe for passengers crossing in front of the bus</li> </ul>
Far Side	<ul style="list-style-type: none"> <li>Minimizes conflicts between right-turning vehicles and buses</li> <li>Optimal location for traffic signal synchronized corridors</li> <li>Provides additional right-turn capacity by allowing traffic to use the right lane</li> <li>Improves sight distance for buses approaching intersections</li> <li>Requires shorter deceleration distances for buses</li> <li>Signalized intersections create traffic gaps for buses to reenter traffic lanes</li> <li>Improves pedestrian safety as passengers cross in back of the bus</li> </ul>	<ul style="list-style-type: none"> <li>Queuing buses may block the intersection during peak periods</li> <li>Sight distance may be obstructed for vehicles approaching intersections</li> <li>May increase the number of rear-end accidents if drivers do not expect a bus to stop after crossing an intersection</li> <li>Stopping both at a signalized intersection and a far-side stop may interfere with bus operations</li> </ul>
Mid-Block	<ul style="list-style-type: none"> <li>Minimizes sight distance problems for pedestrians and vehicles</li> <li>Boarding areas experience less congestion and conflicts with pedestrian travel paths</li> <li>Can be located adjacent to or directly across from a major transit midblock use generator</li> </ul>	<ul style="list-style-type: none"> <li>Decreases on-street parking supply (unless mitigated with a curb extension)</li> <li>Requires a mid-block pedestrian crossing</li> <li>Increases walking distance to intersections</li> <li>Stopping buses and mid-block pedestrian crossings may disrupt mid-block traffic flow</li> </ul>

Source: Federal Transit Administration (FTA), *BRT Stops, Spacing, Location, and Design*, [www.fta.dot.gov/research\\_4361.html](http://www.fta.dot.gov/research_4361.html)

In general, bus stops should be located at the far side of a signalized intersection in order to enhance the effectiveness of traffic signal synchronization or bus signal priority projects. Near-side bus stops are appropriate for stop sign-controlled intersections. But in all cases priority should be given to the location that best serves the passengers.



## SIGNAL TREATMENT

Signal prioritization is a component of technology-based “intelligent transportation systems” (ITS). These systems are often used by road authorities in conjunction with transit agencies to help improve a roadway system’s overall operations in the following ways:

- Reduce traffic signal delays for transit vehicles
- Improve an intersection’s person throughput
- Reduce the need for transit vehicles to stop for traffic at intersections
- Help reduce transit vehicles’ travel time
- Help improve transit system reliability and reduce waiting time for people at transit stops

Signal prioritization projects include signal timing or phasing projects and transit signal priority projects.

**Signal timing projects** optimize the traffic signals along a corridor to make better use of available green time capacity by favoring a peak directional traffic flow. These passive systems give priority to roadways with significant transit use within a district-wide traffic signal timing scheme. Transit signal prioritization can also be achieved by timing a corridor’s traffic signals based on a bus’s average operating speed instead of an automobile’s average speed.

**Transit signal-priority projects** alter a traffic signal’s phasing as a transit vehicle approaches an intersection. This active system requires the installation of specialized equipment at an intersection’s traffic signal controller and on the transit vehicle. It can either give an early green signal or hold a green signal that is already being displayed in order to allow buses that are operating behind schedule to get back on schedule. Signal-priority projects also help improve a transit system’s schedule adherence, operating time, and reliability.

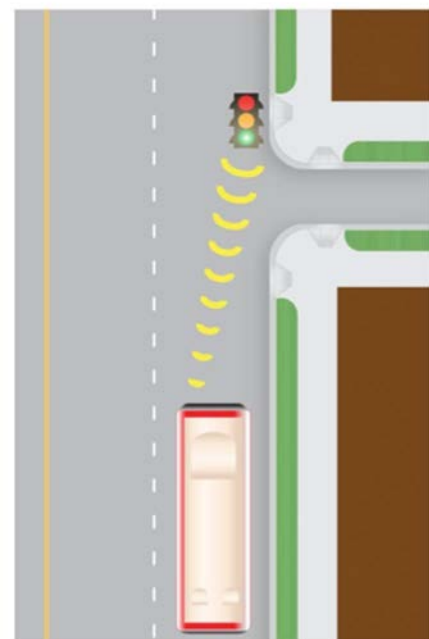

*Signal-priority technology can help to reduce delay for buses  
 (Credit: Michele Weisbart)*

Although they may use similar equipment, signal-priority and pre-emption are two different processes. Signal-priority modifies the normal signal operation process to better accommodate transit vehicles, while signal pre-emption interrupts the normal signal to favor transit or emergency vehicles.

The placement of a bus stop at the far side of a signalized intersection increases the effectiveness of transit signal-priority projects. Signal treatments should be used along streets with significant bus service.



## URBAN DESIGN

Bus stops and amenities vary in complexity and design from standardized off-the-shelf signs and furniture to specially designed elements. The design of the bus stop elements, location of the bus stop in relation to adjacent land uses or activities, and the quality of the roadway's pedestrian environment contribute to a bus stop's placemaking. Transit operators like a branded look to their stops so they are easily identified, but often there is room for customized designs to fit in with the neighborhood, with at least some of the features and amenities.



*Bus stops should be integrated with their surroundings*  
(Credit: Kimley-Horn and Associates, Inc.)

## BICYCLE CONNECTIONS

Connecting bicycle facilities to transit stations helps extend the trip length for cyclists and reduces automobile travel. Secure bicycle parking must be provided at or within close proximity to a bus stop, preferably sheltered. At a minimum, the accommodations can be bike racks or lockers. Bike stations and automated bicycle parking can be located at areas with high levels of transit and bicycle use.



*Integrating bicycle parking with transit enhances multimodal connectivity*  
(Credit: Kimley-Horn and Associates, Inc.)

## BUS LANES

Bus lanes provide exclusive or semi-exclusive use for transit vehicles to improve the transit system's travel time and operating efficiency by separating transit from congested travel lanes. They can be located in an exclusive right-of-way or share a roadway right-of-way. They can be physically separated from other travel lanes or differentiated by lane markings and signs.

Bus lanes can be located within a roadway median or along a curb-side lane, and are identified by lane markings and signs. They should generally be at least 11 feet wide, but where bicycles share the lane with buses,



*Dedicated bus lane*  
(Credit: Kimley-Horn and Associates, Inc.)



13 to 15 feet wide is preferred. When creating bus lanes, local jurisdictions should consider the following:

- Exclusive transit use may be limited to peak travel periods or shared with high-occupancy vehicles.
- On-street parking may be allowed depending on roadway design, especially with bus lanes located in the center of the street.
- A mixed-flow lane or on-street parking may be displaced; this is preferable to adding a lane to an already wide roadway, which increases the crossing distance for pedestrians and creates other problems discussed in other chapters.
- Within a mixed-flow lane, the roadway can be delineated by striping and signs.
- High-occupancy vehicles and/or bicycles may be permitted to use bus lanes.

Pedestrian access to stations becomes an issue when bus lanes are located in roadway medians.



*Bus-only lane: Santa Monica, CA  
(Credit: Sky Yim)*



*Median bus lanes  
(Credit: Broward MPO)*



## BUS BULBS

Enhance transit facilities to encourage use. Bus bulbs are curb extensions that extend the length of the transit stop on streets with on-street parking. They improve transit performance by eliminating the need for buses to merge into mixed traffic after every stop. They also facilitate passenger boarding by allowing the bus to align directly with the curb; waiting passengers can enter the bus immediately after it has stopped. They improve pedestrian conditions by providing additional space for people to wait for transit and by allowing the placement of bus shelters where they do not conflict with a sidewalk's pedestrian zone. Bus bulbs also reduce the crossing distance of a street for pedestrians if they are located at a crossing. In most situations, buses picking up passengers at bus bulbs block the curbside travel lane; but this is mitigated by the reduced dwell time, as it takes less time for the bus driver to position the bus correctly, and less time for passengers to board.



*Bus bulb: Alhambra, CA (Credit: Sky Yim)*

One major advantage of bus bulbs over pulling over to the curb is that they require less parking removal: typically two on-street parking spots for a bus bulb instead of four for pulling over.

The following conditions should be given priority for the placement of transit bus bulbs:

- Where transit performance is significantly slowed by the transit vehicle's merging into a mixed-flow travel lane
- Roadways served by express or Bus Rapid Transit (BRT) lines
- Stops that serve as major transfer points
- Areas with heavy transit and pedestrian activity and where narrow sidewalks do not allow for the placement of a bus shelter without conflicting with the pedestrian zone



*Bus bulb: Huntington Park, CA (Credit: Sky Yim)*



Bus bulbs should not be considered for stops with any of the following:

- A queue-jumping lane provided for buses
- On-street parking prohibited during peak travel periods
- Near-side stops located at intersections with heavy right-turn movements, except along streets with a “transit-first” policy

**CHARACTERISTICS**

At a minimum, bus bulbs should be long enough to accommodate all doors of a transit vehicle to allow for the boarding and alighting of all passengers, or be long enough to accommodate two or more buses (with a 5-foot clearance between buses and a 10-foot clearance behind a bus) where there is frequent service such as with BRT or other express lines. Bus bulbs located on the far side of a signalized intersection should be long enough to accommodate the complete length of a bus so that the rear of the bus does not intrude into the intersection.

**Table 10.2 Standard Transit Vehicle and Transit Bus Bulb Dimensions**

Vehicle	Length (feet)	Number of Buses at Stop	Platform Length (feet)	
			Near Side	Far Side
Standard bus	40	1	35	45
		2	55	65
Articulated bus	60	1	80	90
		2	120	130

Federal Transit Administration, August 2004. *Characteristics of Bus Rapid Transit for Decision Making* Project NO: FTA-VA-26-7222-2004.1



*BCT bus at a Tri-Rail Station  
 (Credit: Kimley-Horn and Associates, Inc.)*



## ACCOMODATING LIGHT RAIL, STREET CARS, and BRT

A growing number of streets have light rail lines, street cars, or Bus Rapid Transit (BRT). These need to be carefully designed into the street.

The various options for accommodating light rail, street cars, and BRT within streets are as follows:

- Center-running
- Two-way split-side, with one direction of transit flow in each direction
- Two-way single-side, with both directions of transit flow on one side of the street right-of-way
- One-way single-side, with transit running one direction (either with or against the flow of vehicular traffic) and usually operating in a one-way couplet on parallel streets.



*Light-rail in urban street: San Diego Blue Line  
(Credit: Kimley-Horn and Associates, Inc.)*

For each configuration, transit can operate in a reserved guideway or in mixed street traffic. When installing light rail or street cars within streets, the safety of pedestrians and bicyclists needs to be fully provided for. If poorly designed, these transit lines introduce hazards and serve to divide neighborhoods where crossings are highly limited and/or difficult or inconvenient (see Chapter 8, “Pedestrian Crossings” for more guidance). In general, in areas of high pedestrian activity, the speed of the transit service should be compatible with the speed of pedestrians.



*Busway in median with center platform stations:  
TransMilenio BRT, Bogotá, Colombia  
(Credit: Stewart Robertson)*



Tampa Streetcar arriving at station shelter  
(Credit: Kimley-Horn and Associates, Inc.)

The potential for each configuration is influenced by the street type. Some transit configurations will not work effectively in combination with certain street types. Table 10.3 outlines the compatibility of each configuration with the four street types.

**Table 10.3 Street Types and Transit Configurations**

Street Type	Center Running		Two-Way Split Side		Two-Way Single Side		One-Way Single Side	
	Reserved Guideway	In Street	Reserved Guideway	In Street	Reserved Guideway	In Street	Reserved Guideway	In Street
Boulevard	Y	N	N	Y	Y	N	Y*	Y
Multi-way Boulevard	Y	N*	Y	Y	N	N	Y*	Y
Avenue	Y	Y	Y*	Y	Y*	N	Y	Y
Street	N	Y	Y	Y	N*	N	Y	Y

**Notes**

Y = Recommended street type/transit configuration combination

N = Not recommended/possible street type/transit configuration combination

\*Denotes configurations that may be possible under certain circumstances, but are not usually optimal

Source: Integration of Transit into Urban Thoroughfare Design, DRAFT White Paper prepared by the Center for Transit-Oriented Development, updated: November 9, 2007.



This page left blank intentionally.



## 11. TRAFFIC CALMING

DEFINITION .....	1
CATEGORIES.....	2
SAFETY .....	4
EMERGENCY RESPONSE AND NUMBER OF PERIODIC MEASURES .....	6
Exceptions.....	6
Design Vehicle.....	7
GENERAL POLICY GUIDANCE .....	7
Tort Liability .....	7
Traffic Calming Contexts.....	8
Planning and Design Processes.....	11
IMAGE GALLERY .....	14



*(Credit: Broward County Traffic Engineering Division)*



## DEFINITION

During the public outreach period for the *Broward Complete Streets Guidelines*, a common theme heard was a strong desire to slow down traffic speeds. While traffic calming takes various approaches, the outcome is usually the same: reduced traffic speeds.

*Traffic calming is the combination of mainly physical measures that (i) reduce the negative effects of motor vehicle use, (ii) alter driver behavior, and (iii) improve conditions for non-motorized street users.*



*Traffic calmed street (Credit: Dan Burden)*

The phrase, “the combination of mainly physical measures,” means physical measures plus a supportive policy environment such that traffic calming is permitted and encouraged.

“Reduce the negative effects of motor vehicle use” means changing the role and design of streets to accommodate motorists in ways that reduce the negative social and environmental effects on individuals, neighborhoods, districts, retail areas, corridors, downtowns, and society in general (e.g., reduced speeds, reduced sense of intrusion/dominance, reduced energy consumption and pollution, reduced sprawl, and reduced automobile dependence).

“Alter driver behavior” means that the street design helps drivers self-enforce lower speeds, resulting in less aggressive driving and increased respect for non-motorized users of the streets. “Improve conditions for non-motorized street users” means promoting walking and cycling, changing expectations of all street users to support equitable use of the street, increasing



safety and comfort (i.e., the feeling of safety), improving the aesthetics of the street, and supporting the context of the street.

The definition of traffic calming is broad enough to apply to a myriad of contexts and situations but specific enough to have independent meaning so that it is not confused with other street design elements and design approaches.

Through design, traffic calming aims to slow the speeds of motorists to the “desired speed” (usually 20 mph or less for residential streets and 25 to 35 mph for boulevards and avenues) in a context-sensitive manner by working with the stakeholders (i.e., residents, business owners, and agencies). Traffic calming is acceptable on all street types where pedestrians are allowed. One exception is Broward County Transit’s (BCT’s) stated desire to not have vertical speed deflections (such as speed tables and speed cushions) on streets that BCT buses utilize.

*“It’s more dangerous to walk than travel by car, because of speed, it does not matter where you live, people are always in a hurry.”*

- (Broward Complete Streets survey respondent)

Traffic calming typically connotes a street or group of streets that employ traffic calming measures with a “self-enforcing” quality that physically encourages motorists to drive at the desired speed. When a group of streets are involved, it is normally referred to as “area-wide calming.”

Traffic calming measures can also be designed to treat and manage streetwater.

## CATEGORIES

From a policy and design perspective, traffic calming measures fall into two broad categories: those that are appropriate for “framework” streets and those that are appropriate for both framework streets and “non-framework” streets. Framework streets are streets that (i) connect places, neighborhoods, and districts (usually most boulevards and avenues) and/or (ii) serve as emergency vehicle routes. The sorts of traffic calming measures that are appropriate on framework streets include “cross-section measures”



Median traffic calming measure: Plantation  
(Credit: Kimley-Horn and Associates, Inc.)



because emergency response times are generally unaffected by cross-section changes. Non-framework streets are all the other streets in the street network. The majority of streets in local jurisdictions are non-framework streets. Non-framework streets provide access to houses, businesses, offices, and parks, and are rarely used by emergency vehicles except for local calls. The sorts of traffic calming measures that are appropriate for non-framework streets include cross-section measures and “periodic measures.” Periodic measures are spaced intermittently, rather than continuously. They are very popular on non-framework streets because they are inexpensive when compared to cross-section measures, which typically require construction along the entire length of the street. Examples of both types of measures and guidance for their use are shown above and below.

The correct terminology for traffic calming is “measures” not “devices.” “Devices” implies a degree of portability that does not apply to most traffic calming measures. The use of “devices” also causes confusion with the contents of the Manual on Uniform Traffic Control Devices (MUTCD). Adding street trees and changing the paving material to provide texture or contrast, for example, are measures to alter behavior and perceptions but they are clearly not “devices.”



*Periodic traffic calming measure: Raised crosswalk in Seattle, WA (Credit: Ryan Snyder)*



*Partial closure: Riverside, CA (Credit: Ryan Snyder)*

“Route modifications measures” are not true traffic calming measures. Examples of route modifications measures include street closures, partial closures, turn prohibitions, diverters, and one-way streets. Route modifications effectively remove parts of the network. Route modifications result in circuitous and out-of-direction routing. The resulting trips are longer and burn more fuel; thus, circuitous routing can increase driver frustration and result in higher speeds. Route modification should be used sparingly and generally where traffic is diverted to boulevards to reduce cut-through traffic, or on bike boulevards to reduce their use by through motor vehicle traffic.

Lastly, signs, pavement markings, and on street parking are often used in conjunction with traffic calming measures, but they are traffic control devices, not traffic calming measures.



## SAFETY

The greatest benefit of traffic calming is increased safety. Compared with conventionally designed streets, traffic calmed streets typically have fewer collisions and even higher reductions in injuries and fatalities. These dramatic safety benefits are mostly the result of slower speeds for motorists that result in greater driver awareness, wider fields of vision, shorter stopping distances, and less kinetic energy during a collision. At 20 mph or less, chances are high that a motorist will not kill or severely injure a pedestrian in a collision. Other contributing factors to these superior safety results include a more legible street environment and design advantages for pedestrians and cyclists. Bulb-outs on corners of intersections, for example, allow pedestrians to see past parked cars prior to crossing the street.



Peripheral vision at 15 mph



Peripheral vision at 30 mph

*Peripheral vision decreases at higher speeds. (Credit: Michele Weisbart)*

The accommodation and comfort of pedestrians increases greatly as speeds lower. For example, acceptable gaps (i.e., the space between moving vehicles) are better judged at slower speeds. Also, at 25 mph or less drivers are much more likely to yield to pedestrians and let them cross the street than at over 25 mph. The chart on the next page shows that it takes a longer distance to brake and come to a full stop as speeds increase.

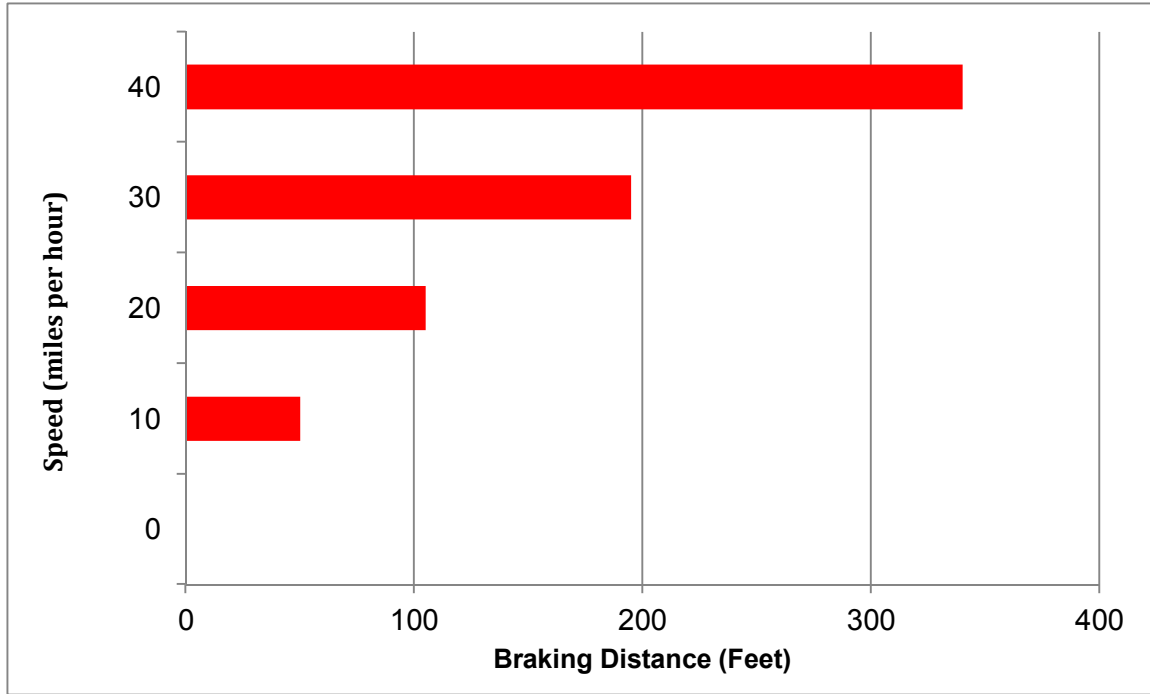

Source: (Federal Highway Administration, *Pedestrian Safety Design Course*)

The chart below illustrates that crashes become more severe with speed.

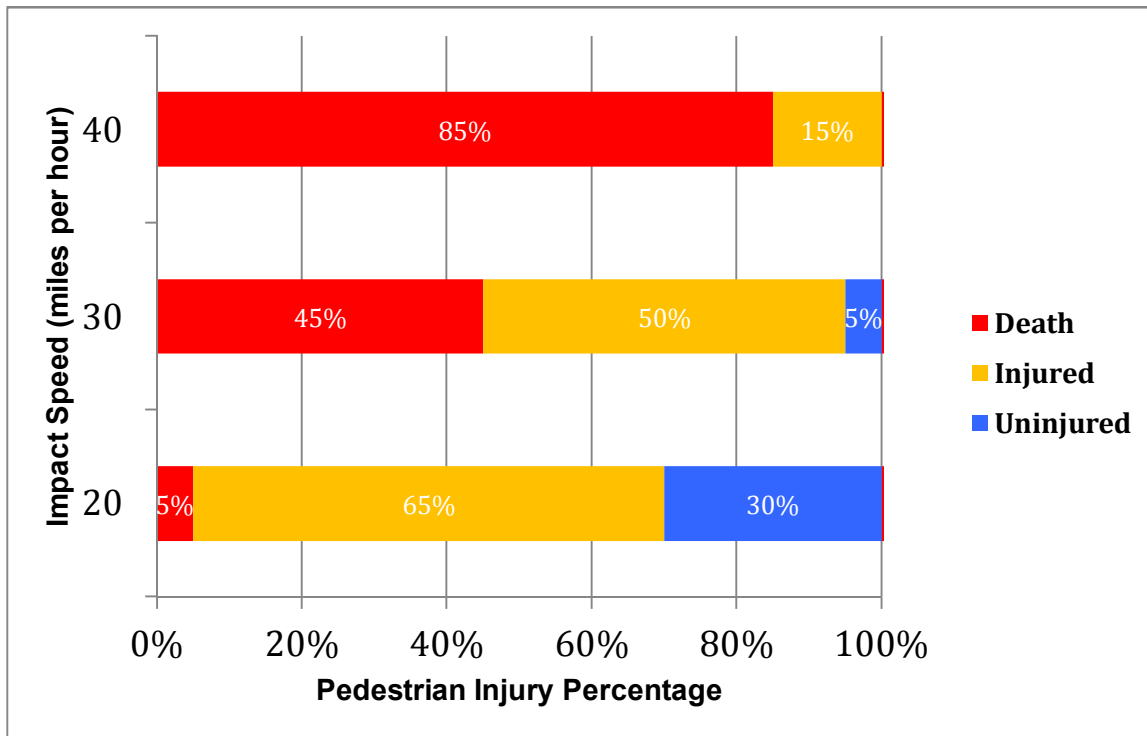

Source: *Killing Speed and Saving Lives*, UK Department of Transportation.



## EMERGENCY RESPONSE AND NUMBER OF PERIODIC MEASURES



*Designing traffic calming to accommodate emergency response. (Credit: Dan Burden)*

It is important to have a network of framework streets so that emergency personnel can get to, or reasonably close to, calls without encountering too many periodic measures. In this way, all or most of the length of the responders' trips are on framework streets and, if any periodic measures are encountered, then they are encountered only towards the end of the trip. From an emergency perspective and a public acceptability perspective, it is important to limit the number of periodic measures in a row on non-framework streets. The rule of thumb is, on the routes between two framework streets there should be no more than 8 to 12 periodic measures. If more than 8 to 12 periodic

measures are used in a row, motorists who use the streets will become highly irritated with the measures and will have them removed. This rule of thumb effectively limits the length of single-street traffic calming projects. It also limits the size of the area for area-wide calming (i.e., the maximum limit is 8 to 12 multiplied by the spacing between the measures).

To achieve a desired speed of 20 mph using periodic measures, the spacing between the measures should be about 250 to 300 feet. Typically, measures are constructed at the obvious locations (i.e., pedestrian crossings, intersections, and curves) and then subsequent measures are filled in to attain the correct spacing. In this way, a slow and steady speed profile is achieved; there is little opportunity or utility for motorists to speed up between the measures.

### EXCEPTIONS

There are two general exceptions to the above recommendations:

- Some local streets should be classified as framework streets due to their long lengths and inability to be effectively calmed with no more than 8 to 12 periodic measures at the correct spacing.
- Periodic measures are appropriate on framework streets in some situations. Examples include locations with heavy pedestrian generators (e.g., at elementary schools, community centers, entertainment venues, and key intersections along a main street or in a downtown).



## DESIGN VEHICLE

In general, all public streets and traffic calming measures should be designed to accommodate a WB-40 design vehicle (i.e., a tractor trailer with a 40-foot wheel base). The WB-40 design vehicle uses more space to turn than fire trucks, school buses, garbage trucks, and most service trucks. Therefore, if the WB-40 fits, all the rest fit. On streets where larger design vehicles are permitted and are expected to use the streets regularly, then the design vehicle should be changed accordingly. While all streets should be designed to accommodate WB-40 vehicles, they should not be the primary design vehicle on non-framework streets. And this does not mean that every radius must be large enough to accommodate them as large trucks may use the full width of the street they are turning into. These streets should be narrow and require reduced speeds to turn at intersections, especially for large vehicles.

## GENERAL POLICY GUIDANCE

For local jurisdictions initiating a traffic calming policy, the most important items to include are the following:

- The correct definition of traffic calming
- General statements of support for traffic calming throughout the city and experimentation with traffic calming for a variety of rationales
- A chart of examples of acceptable measures on different categories of streets
- A reference to traffic calming practices and procedures that will be maintained at the staff level

The last item is important because local jurisdictions need the flexibility to adapt their programs, include updated practices and measures as they are developed or discovered, and react to changing circumstances. **If practices and procedures are adopted by ordinance or resolution, then the traffic calming policy will be out-of-date quickly or will hamper local jurisdictions' ability to address unique contexts.**

## TORT LIABILITY

The low speed environment of a traffic calmed street is a difficult place for someone to be “victimized” by a fault in the road design. Consequently, there are very few tort actions associated with traffic calming. Furthermore, there are fewer collisions and far fewer injuries and deaths on traffic calmed streets than streets with higher speeds. It is recommended that some simple and routine actions are followed:

- In local jurisdictions' statements for supporting traffic calming, some broad rationale should be listed so that traffic calming cannot be considered “capricious.” Examples should include to increase safety, increase walkability, increase community cohesion,



and increase business viability; historic preservation and environmental protection; and to further the goals and objectives of the community and city in a variety of contexts.

- Local jurisdictions should conduct normal monitoring for maintenance, complaints, incidents, and collisions. This need not be anything more than the normal reporting systems but with some additional attention paid to streets with new modifications.

## TRAFFIC CALMING CONTEXTS

Early traffic calming efforts in North America started as “programs” and often used a variety of warrants and petitions. However, traffic calming has evolved and there are many reasons to calm traffic; a city doesn’t need special permission or warrants to increase the safety and comfort of its streets. In many ways, traffic calming is synonymous with other terms that are used to encourage better street designs. Depending on the term, the emphasis differs, but in all cases traffic calming measures play a role.

### Context-Sensitive Design (CSD)

CSD implies that the context (i.e., the social, historical, physical, fiscal, political, environmental, and policy contexts) drive the design as opposed to the conventional street hierarchy. Typically, conventional practices use general design guidelines that are indifferent to the context. Frequently, contexts along conventional streets in local jurisdictions suffer from some combination of negative effects of motor vehicle use, poor driver behavior, and poor conditions for non-motorized street users. Consequently, CSD often employs traffic calming measures to respect the context of the street and neighborhood.

### Smart Transportation

This term describes the transportation aspects of smart growth. The idea is to consider “transportation planning and design” as integral with “land use planning and design,” as opposed to separate ideas. Too often, the two are done by separate specialists and for independent reasons. Traffic calming measures play an important role in the design of all scales of streets in local jurisdictions when integration with the adjacent land use is desired. Through the TOUCH Grant, the Broward Regional Health Planning Council has married the two programs together and is working to ensure seamless coordination between complete streets and Smart Growth policies.

### Safe Routes to School

Safe Routes to School (SRTS) includes a series of operational and physical changes that help students walk and cycle to and from schools. Traffic calming measures are routinely employed with other strategies and changes to create safer walking and bicycling routes to school by slowing traffic.



### Neighborhood Traffic Management

This term describes the combination of the following techniques.

- Route modifications (e.g., turn prohibitions, closures, partial closures, diverters, and one-way streets) to remove parts of the street network, sever linkages, create mazes, or reduce connectivity.
- Speed control measures to delay motorists who cut through neighborhoods.
- Traffic calming to reduce poor driver behavior (e.g., speeding and aggressive driving).

Please note that in most situations, diminishing the street network is not considered good practice. Bicycle boulevards are a primary exception to this rule; traffic control devices are desirable on bicycle boulevards to discourage through motor vehicle traffic. Route modification may also be used to reduce cut-through traffic where the traffic will be diverted to a boulevard.

### Shared Space

Shared space uses the design of the public realm (i.e., the space between the buildings) to cause all of the street users to communicate, interact, and behave safely without (i) the reliance on conventional traffic control devices doing the communicating for them, and (ii) the conventional allocation of separate lanes/spaces that accompany the conventional and often less safe “safety-through-separation” theories. Many traffic calming measures, such as texture, paving color changes, lateral shifts, and enclosure, are employed in shared spaces.



*Shared space: Groningen, Holland  
(Credit: Ryan Snyder)*

### Road Diet

This term describes the narrowing and/or removal of motor vehicle lanes from the cross-section. Both of these changes are traffic calming measures. Typically, the reclaimed space is used for other purposes such as wider sidewalks, landscaped spaces, bicycle lanes, linear parks, and/or on-street parking. Often, road diet projects employ other traffic calming measures as well. Roundabouts often enable implementation of road diets, especially on busier boulevards since they have greater capacity to handle traffic at intersections with fewer lanes than other controls.

### Competent Street Design

Competent street design combines all of the above. There is little excuse any more to ignore the context or to build incomplete, dangerous, or poorly integrated streets. The issue for traffic calming is not justification but prioritization. If there are problems with a conventionally



designed street, then traffic calming is warranted. The questions are how to calm, when to calm, and how the project compares to other priorities in the city.

Obviously, an early priority for any city is to incorporate traffic calming measures into normal street design practices and procedures to help any new/future streets avoid the deficiencies of conventionally designed streets. The harder part is prioritizing the rebuilding or retrofitting of the myriad of already built conventionally design streets. Rebuilding or retrofitting these streets should be prioritized based on the context, in the broadest sense. Candidates for calming might include the following:



*Curb extensions enhance retail districts:  
 Asheville, North Carolina (Credit: Ryan Snyder)*

- Key shopping streets in the downtown area
- Waterfront streets, which commonly attract pedestrians who would benefit if the streets were calmed
- Neighborhood streets
- Large arterials (boulevards) that create barriers in the city

Consequently, allocating street redesign money based on warrants or numerical scores is not recommended because the contexts and scope vary too much. In the early days of North American traffic calming, special traffic calming programs were established with warrants that focused primarily on motor vehicle speeds, volumes, and collisions on residential streets. Warrants were popular in the early traffic calming programs because, at the time, traffic calming was new and unfamiliar. Traffic calming was thought of as an independent program for residential streets only.

Scoring schemes are problematic. For example, if a threshold score is exceeded on one block or at one intersection but nowhere else on the street, traffic calming the one location does not make sense. A single periodic measure used alone that does not result in a slow and steady speed profile is known as an “orphan.” Periodic traffic calming measures rely on other measures along the street at the correct spacing to be most effective. Furthermore, the individual score or warrant cannot anticipate shifting a problem to a parallel street. In other words, the scoring systems cannot anticipate transfer effects. Area-wide calming requires judgment.

Numerical scores leave out key contextual considerations (i.e., school area, retail area, parks, presence of sidewalks, right-of-way widths, and building setbacks) and thus are incomplete. Many scoring schemes rank projects on auto-related criteria such as volume, speed, crashes, etc. This method ignores other street users such as pedestrians and cyclists. The scores require



a lot of effort to gather, analyze, and compare. They also provide a false sense of objectivity because the fundamental choice of what to measure is subjective as is the weighting of the measures. It is difficult to correlate the scoring with a city's, district's, downtown's, corridor's, or neighborhood's vision, goals, objectives, and broader priorities. These priorities may include revitalization, community cohesion, housing, or others.

Instead, traffic calming should be a normal part of a city's, district's, downtown's, corridor's, or neighborhood's plans and a normal part of the budgeting process. It should be incorporated into resurfacing, utility replacement, and other programs. Every time a conventional street gets attention, the replacement design should include traffic calming as normal practice. Traffic calming should be the rule, not the exception, and special permission to not calm should be sought in those instances. Competing areas, neighborhoods, and districts that want traffic calming need to express their desires through the normal planning and capital works programs.

Requiring petitions is not recommended either, as they can be expensive, distracting, and divisive. Outcomes can vary depending on the wording of the petition; the business people's, property owners', and residents' understanding of the related issues; and the people who are collecting the signatures. Petitions can make the task of designing a context-sensitive, traffic calmed street very difficult.

#### Traffic Calming and Streetwater Management

Traffic calming measures, such as bulb-outs, roundabouts, traffic circles, chicanes, lane narrowing, and others, can be used as streetwater management tools. Some of these can create space for bioretention, detention, and pervious pavement.

#### PLANNING AND DESIGN PROCESSES

Traffic calming redevelopment should be a normal part of any city's planning and design processes, as well as ADD-budgeted processes. The processes will vary dramatically depending on the context. For example, implementing a road diet in conjunction with a transit facility along a five-mile boulevard would require a different process than reverting one-way streets back to two-way operation in a downtown. Similarly, a neighborhood traffic calming plan would require a different process than designing a people-friendly Main Street. Also, identifying boulevard streets that are barriers in a city during comprehensive planning would require a different process than altering streets on a college campus or hospital campus.

The common threads that link all of the processes include the following:

- Gaining a good understanding of the context
- Involving the stakeholders in the definition of the problems to be solved and aspirations to be fulfilled
- Educating the stakeholders such that they can have meaningful involvement

- Aligning the project with a broader vision for the area
- Achieving an informed consent regarding the plan

Traffic calming is best done in conjunction with a development, revitalization, utility, or maintenance project; a downtown, corridor, or transit plan; a new street design; or other project. Then the traffic calming layer is simply incorporated into the larger project’s processes.

Table 11.1 illustrates acceptable traffic calming measures on various types of streets.

**Table 11.1: Representative Examples of Traffic Calming Measures and their Appropriateness on Various Street Categories**

Traffic Calming Classification		Framework Street			Framework Street or Non-Framework Street		Non-Framework Street	
		Boulevards in Transition (partially calmed)	Regional Boulevard	Community Boulevard	Community Avenue	Neighborhood Avenue	Local Street	
Conventional Street Classification								
Posted / Design / Target / Operating Speed (mph)		35 mph +	25 to 30 mph	20 to 30 mph	20 to 30 mph	20 to 25 mph	20 mph or below	
Transition Zone from / to higher speed environment		Yellow	Green	Green	Red	Red	Red	
Entrance Features (architecture / landscaping / monument)		Green	Green	Green	Green	Green	Green	
Cross-Section Measures	Reduction in number of lanes	Green	Green	Green	Green	Green	Green	
	Reduction in width of lanes	Green	Green	Green	Green	Green	Green	
	Long Median / Continuous Median	Green	Green	Green	Green	Green	Green	
	Short Median / Refuge	Green	Green	Green	Green	Green	Green	
	Short Medians on Curves	Green	Green	Green	Green	Green	Green	
	Bulb-outs	Green	Green	Green	Green	Green	Green	
	Curb and Gutter	Green	Green	Green	Green	Green	Green	
	Curbless / Flush Streets	Red	Green	Green	Green	Green	Green	
	Flush Medians	Green	Green	Green	Green	Green	Green	
	Pedestrian Scale Lighting	Green	Green	Green	Green	Green	Green	
	Street Trees	Green	Green	Green	Green	Green	Green	
	Building up to the right-of-way	Green	Green	Green	Green	Green	Green	
	Lateral Shifts	Red	Green	Green	Green	Green	Green	
	Shared Spaces	Red	Green	Green	Green	Green	Green	
	Bike Lanes / Protected Bike Lanes / Cycle Tracks	Green	Green	Green	Yellow	Yellow	Yellow	
	Textured and/or Colored Paving Materials (parking, lanes, bike lanes, crossings, intersections, general purpose lanes, turn lanes, medians)		Green	Green	Green	Green	Green	Green
	On-street Parking	Parallel	Yellow	Green	Green	Green	Green	Green
		Back-in-angled	Yellow	Green	Green	Green	Green	Green
Front-in-angled		Red	Red	Red	Red	Red	Green	
Right-angle		Red	Red	Red	Red	Red	Green	
Valley gutters used in conjunction with parking		Green	Green	Green	Green	Green	Green	



Traffic Calming Classification			Framework Street			Framework Street or Non-Framework Street			Non-Framework Street		
Periodic Measures	Horizontal Measures	Roundabouts									
		Mini Roundabouts									
		Mini Traffic Circles									
		Impellers (T-intersections)									
		Two-lane chicanes									
		One-lane chicanes (yield condition)							< 3,000 ADT	< 3,000 ADT	< 3,000 ADT
		Short medians									
		Medians on curves									
	Narrowings	Yield Streets							< 1,500 ADT	< 1,500 ADT	< 1,500 ADT
		Pinch Points							< 3,000 ADT	< 3,000 ADT	< 3,000 ADT
		Bulb-outs									
	Vertical Measures	Raised Intersections									
		Raised Crosswalks									
		Flat-top Speed Humps (speed tables)									
		Speed Cushions									
Speed Humps											
Not Traffic Calming Measures	Vertical Changes	Rumble Strips (for warning purposes)	In rural areas only								
		Speed Bumps									

Note: Many of these measures can be combined in a variety of ways that are too numerous to list in this chart.

Legend:

Appropriate
Appropriate in Specific Circumstances
Not Appropriate

The following photos illustrate some of these measures.



IMAGE GALLERY



*Reduction in widths (Credit: Ian Lockwood)*

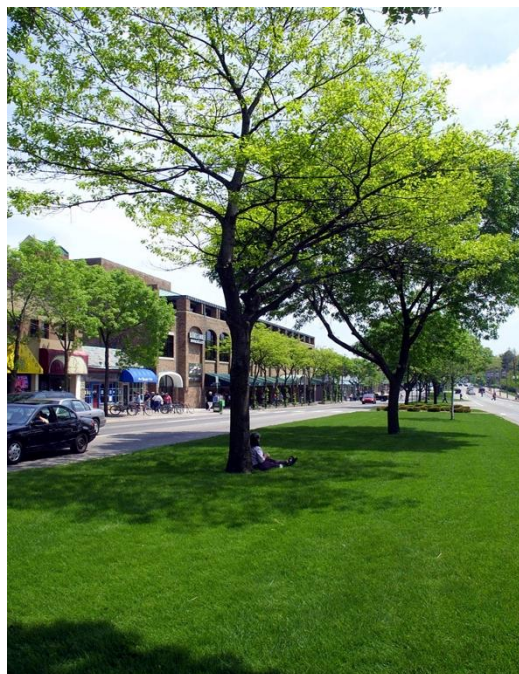

*Long, continuous median  
(Credit: Ian Lockwood)*



*Short median with refuge (Credit: Kimley-Horn and  
Associates, Inc.)*



*Short median on curve (Credit: Michael Wallwork)*



*Rubber speed cushions (Credit: Unknown)*



*Curbless median (Credit: Ian Lockwood)*



*Speed table and lane narrowing with warning sign  
(Credit: Kimley-Horn and Associates, Inc.)*



*Lateral shifts (Credit: Ian Lockwood)*



*Textured pavement (Credit: Ian Lockwood)*

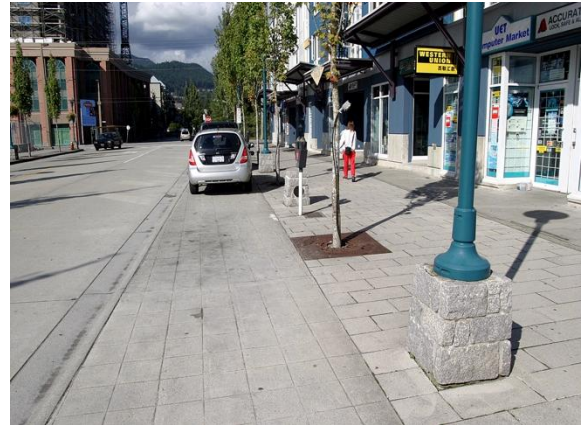

*Valley gutter (Credit: Ian Lockwood)*



*Short median adjacent to uncontrolled intersection (Credit: Kimley-Horn and Associates, Inc.)*



*Roundabout with splitter islands for pedestrian crossings (Credit: Kimley-Horn and Associates, Inc.)*



*Mini-roundabout (Credit: Ian Lockwood)*



*Impeller T-intersection (Credit: Ian Lockwood)*



*Two-lane chicane (Credit: Michael Wallwork)*



*Textured pavement (Credit: Kimley-Horn and Associates, Inc.)*



*One-lane chicane (Credit: Ian Lockwood)*



*Short median (Credit: Ian Lockwood)*



*Neighborhood traffic circle (Credit: Unknown)*



*Raised crosswalk (Credit: Ian Lockwood)*



*Speed cushion (Credit: Ian Lockwood)*



*Oval median (Credit: Michael Wallwork)*



*Mid-block curb extension with bioswale (Credit: Brad Lancaster)*



## 12. STREETSCAPE ECOSYSTEM

INTRODUCTION.....	1
PRINCIPLES OF STREETSCAPE ECOSYSTEM DESIGN .....	2
STREETWATER MANAGEMENT .....	3
Goals and Benefits of Streetwater Management .....	5
Principles of Streetwater Management .....	5
Definitions .....	7
Tools for Streetwater Management.....	8
URBAN FORESTRY.....	33
Street Trees.....	33
Understory Landscaping .....	39
STREET FURNITURE .....	42
Benches and Seating.....	43
Bollards .....	45
Street Vendor Stands.....	46
Kiosks .....	46
News Racks .....	47
Parking Meters .....	48
Signs.....	48
Refuse Receptacles.....	49
Public Art.....	50
Sidewalk Dining .....	51
Other Streetscape Features .....	52
UTILITIES .....	52
Guidelines .....	53
Lighting .....	57
ADDITIONAL RESOURCES.....	59



*(Credit: Kimley-Horn and Associates, Inc.)*



## INTRODUCTION

The street is a system: a transportation system, an ecosystem, and a system of social and economic interactions. The idea of a streetscape ecosystem is to mimic nature, building reciprocal relationships within an interconnected system to sustainably enhance the local environment, its resources, the community, and the local economy. To do this, the tools addressed in this chapter should be integrated with those of the other chapters in this manual.

This chapter is organized into sections based on a natural hierarchy. The first section focuses on streetwater management because water is the fundamental ingredient for other components of a streetscape ecosystem. The streetwater management section provides guidance on how to work with and maximize the beneficial aspects



*Broward Street Tree Canopy  
(Credit: Alena Alberani)*

of rain, its byproduct, stormwater, and other sources of water. The second section addresses street trees and landscaping, providing guidance on how to design streets to include site-appropriate vegetation that maximizes environmental and social benefits. Canopy trees provide summer shade that cools the streets and the hardscapes from which the streetwater is harvested. These sheltered micro-climates create ideal locations for people to gather, walk, and bike.

To help local jurisdictions achieve street designs that create great places fostering community, the final sections of this chapter address street furnishings, utilities, and lighting. The sections recommend that these elements (e.g., sheltered benches, bike racks, and bus shelters) should be placed where people can utilize them well. These sections also provide guidance as to the placement of utilities and how placement coordinates with other components of the streetscape. The elements described can help



attract pedestrians to a street and thereby make the street safer, more dynamic, and more vibrant economically.

## PRINCIPLES OF STREETScape ECOSYSTEM DESIGN

Each section in this chapter includes design principles followed by tools to achieve these principles. These streetscape element-specific principles collectively support both the overarching principles of this chapter and the broader goals of this manual. The collective use of the tools in this chapter can provide numerous aesthetic and functional elements in the public rights-of-way, including the entire space between buildings, traveled way, and sidewalks. The following overarching principles should be applied:

*“Too far, too hot, too rainy,  
too lazy”*

*-- (Broward Complete Street survey  
response to why you are unable to get  
out of your car)*

- **Coordinate all streetscape elements with traveled way design to maximize ecological, economic, and social benefits.** No individual street project should be pursued in a vacuum, but rather planned as part of a comprehensive strategy. Use street medians, roundabouts, chicanes, curb extensions, and other road configurations as space for people and nature. They provide opportunities for spaces with vegetation, streetwater management tools, and other streetscape elements like benches and bike racks.
- **Create a contextualized sense of place.** Using the large menu provided in this chapter, select streetscape elements that reflect the context and unique character of the location as well as support connections to adjacent land uses. The street



*Broward Street Tree Canopy  
(Credit: Alena Alberani)*



can then function as a shared living room for the community and a welcoming front door for the buildings along the street. Native plantings can be used to root the context in the surrounding natural landscape while acknowledging the local ecosystem and climate.

## **STREETWATER MANAGEMENT**

The street is a constructed waterway, often differing from the natural path of water and ignoring the hydrologic cycle. Traditional design has focused on speedy removal of water from the street and disposal of it as waste in storm drains and sewers. This section provides tools to reclaim streetwater as a resource and allow it to nourish trees and soils on its path to ground or surface waters. These tools help local jurisdictions design streets to sustainably work with both dry and wet weather sources of water. During the wet season (summer in Southeast Florida), rain and its byproduct, stormwater, are the primary sources of streetwater. During the dry season (winter in Southeast Florida), man-made sources of water include urban runoff from irrigation, car washing, and other residential, commercial, and industrial activities.

Both dry and wet weather streetwater can contain bacteria and other pollutants, and are thereby regulated at the state and local level. Streets represent a large percentage of the impervious area within Broward County and therefore generate substantial amounts of runoff from storm events. Many of the sources of pollutants to waterways come from streets directly either from motorized vehicles, such as oils, rubber, metals, and galvanized materials, or litter, chemicals, and vegetation debris from adjacent properties.

While conventional stormwater controls aim to move water off-site and into storm drains as quickly as possible, streetwater management seeks to use and store water on-site for absorption and infiltration in order to clean it naturally and use it as a resource. The storm drain system, therefore, is an overflow support system rather than a primary conveyance system. Streetwater management deals with water as an amenity rather than a liability.

Many of the streetwater management options discussed in this section can and should integrate easily with traffic calming measures installed along streets, such as boulevard islands, rotary islands, traffic circles, street ends, chicanes, and curb extensions. These elements can easily incorporate streetwater treatment into the landscape and streetwater tools can be made more cost-effective if integrated early in the design process.

Streetwater management also provides opportunities to leverage other streetscape elements and components of living streets. A strategic plan linking streetscape elements and street design can maximize benefits.

This section provides guidance to comply with Broward County's Municipal Separate Storm Sewer System (MS4) Permit. The MS4 Permit requires that jurisdictions in Broward County reduce contaminants in runoff to improve water quality in waterways. These requirements



stem from National Pollutant Discharge Elimination System (NPDES) requirements of the Clean Water Act, as promulgated by the U.S. Environmental Protection Agency and delegated to Broward County via the Florida Department of Environmental Protection (FDEP).

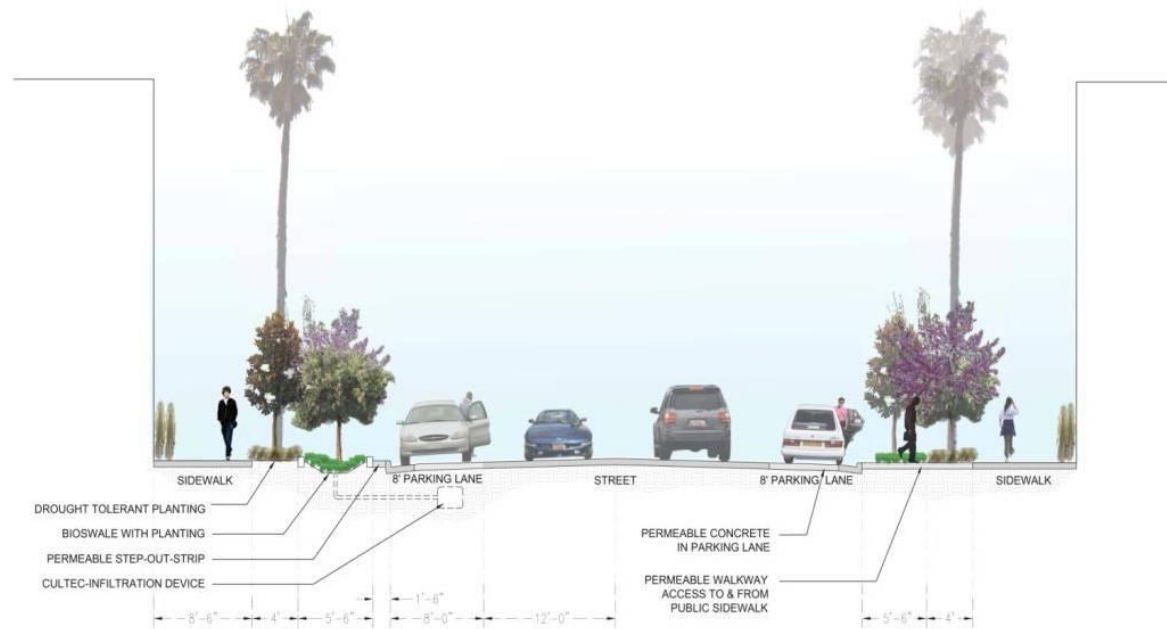

**BICKNELL AVENUE STREET GREENING  
 FINAL CONCEPT / SECTION**



*Parkway incorporating streetwater tools: Bicknell Avenue, Santa Monica, CA  
 (Credit: Neil Shapiro)*



## GOALS AND BENEFITS OF STREETWATER MANAGEMENT

The primary goals of streetwater management are as follows.

- Reduce—limit the amount of impervious surfaces that generate additional runoff
- Slow—friction slows flow
- Spread—allow water to be slowed enough to infiltrate
- Sink—keep water on site
- Store—contain water for direct non-potable/potable indoor/outdoor purposes
- Use—to irrigate and replace imported potable water

These goals can be expressed succinctly: slow it, spread it, store it, and sink it, but use it.

The tools provided in this section enable local jurisdictions to attain regulatory compliance and provide the following ecological, economic, and aesthetic benefits.

- Reduced use of potable water for irrigation
- Reduced surface water pollution
- Support for the urban ecosystem and wildlife habitat
- Enhanced flood control
- Biological filtration and bioremediation
- Groundwater recharge
- Reduced heat island effect
- Education through best management practices (BMP) visibility
- Aeration of root zone
- Potential reductions in stormwater infrastructure and treatment costs
- Improved aesthetics and public space within neighborhoods

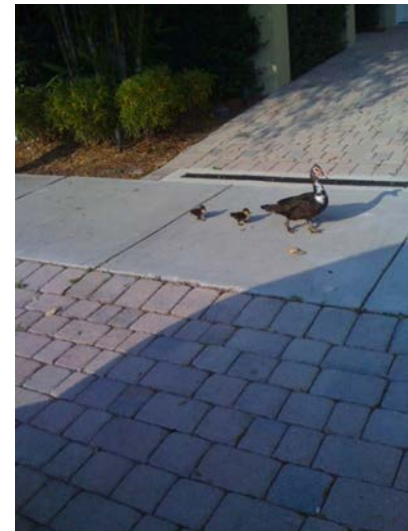

*Design for all users  
 (Credit: Alena Alberani)*

## PRINCIPLES OF STREETWATER MANAGEMENT

- **Use the conventional storm drain system as the overflow approach, not the primary system to manage streetwater.** Wherever possible, natural drainages should be the primary overflow.
- **Harvest, use, and/or store stormwater as close to its source as possible.** Wet weather rainfall and its byproduct, stormwater, can offset or eliminate imported potable irrigation water needs when harvested and used on-site. Harvesting and storing stormwater transforms a flooding liability into an on-site irrigation resource. This ensures natural waterways and their plant communities have local sources of water, thereby reducing the need for imported water. Harvesting and



storing rainwater also reduces the need for costly drainage conveyance infrastructure for stormwater management.

- **Use on-site non-potable water sources for irrigation before any imported water source.** In dry weather, irrigation overspray can be reduced by enforcing existing laws/ordinances banning these practices. This leads to more efficient water use, reducing costly imported potable water consumption.
- **Select tools that mimic natural processes.** Minimize the cost of the installation and maintenance by using gravity flow rather than pumped flow, living filtration over synthetic/mechanical filtration, and living surface infiltration instead of piped drainage. Priority should also be given to pervious versus impervious surfaces. The primary purpose is to harvest and utilize rain as part of a healthy vegetated watershed. For example, vegetation can reduce runoff water volume and pollutant load, provide summer shade and cooling, and enhance wildlife habitat and sense of place with native vegetation rooted to the local ecosystem.
- **Maximize streetwater management by integrating it into the myriad design elements in the public right-of-way.** The water system is part of a larger, interconnected system. Maximize the benefits of stormwater strategies. For example, traffic calming and road diets can double as streetwater harvesting strategies. In addition, use vegetation to make streets better places and use streetwater management as an integral element of the urban forest.
- **Show the water flow.** The benefits of streetwater management are ecological, economic, and social. Make the functions described in this section visible for street users to see, understand, appreciate, and replicate. Public right-of-way streetwater installations can inspire private property installations and serve as model installations for neighborhoods. Visible water flow systems are also easier to maintain. Blockages are easier to notice and easier to access for regular maintenance.



*Native adaptable vegetation  
(Credit: Alena Alberani)*



## DEFINITIONS

The terms below describe the elements and techniques of sustainable streetwater management.

*Best Management Practice (BMP).* Operating methods and/or structural devices used to reduce stormwater volume, peak flows, and/or pollutant concentrations of stormwater runoff through one or more of the following processes: evapotranspiration, infiltration, detention, filtration, and biological and chemical treatment.

*Bioretention.* A soil and plant-based retention practice that captures and biologically degrades pollutants as water infiltrates through sub-surface layers containing microbes that treat pollutants. Treated runoff is then slowly infiltrated and recharges the groundwater. These biological processes operate in all infiltration-based strategies, including various retention systems.

*Conveyance.* The process of water moving from one place to another.

*Daylight.* To bring stormwater or streetwater flow to the surface, exposed to open air and visible to the public.

*Design Storm.* A storm whose magnitude, rate, and intensity do not exceed the design load for a storm drainage system or flood protection project

*Detention.* Stormwater runoff that is collected at one rate and then released at a controlled rate. The difference is held in temporary storage.

*Dry weather runoff.* Human activity-related sources of water, such as irrigation overspray, car wash runoff, leaking plumbing, fire hydrant and well flushing, and runoff from mechanical processes such as air conditioning.

*Filtration.* A treatment process that allows for removal of solid (particulate) matter from water by means of porous media such as sand, soil, vegetation, or a man-made filter. Filtration is used to remove contaminants.

*Hardscape.* Impermeable surfaces, such as concrete or stone, used in the landscape environment along sidewalks or in other areas used as public space.

*Infiltration.* The process by which water penetrates into soil from the ground surface.

*Permeability/Impermeability.* The quality of a soil or material that enables water or air to move through it, and thereby determines its suitability for infiltration-based stormwater strategies.



*Retention.* The reduction in total runoff that results when stormwater is diverted and allowed to infiltrate into the ground through existing or engineered soil systems.

*Runnel.* Narrow, shallow drainage channel designed to carry small amounts of runoff

*Runoff.* Water from rainfall that flows over the land surface that is not absorbed into the ground.

*Sedimentation.* The deposition and/or settling of particles suspended in water as a result of the slowing of the water.

*Softscape.* Natural, permeable, landscape surfaces such as vegetation, mulch, and loose rock.

*Stormwater.* Rainwater that flows and collects in the street.

*Streetwater.* All waters flowing in the street or other hardscapes in the right-of-way, whether from dry weather runoff or rainwater sources.

## TOOLS FOR STREETWATER MANAGEMENT

There are many tools and best management practices (BMPs) for managing streetwater sustainably. Most popular are devices and practices that encourage water percolation on-site to the maximum degree practicable (given soil conditions, pollutant levels, etc.). The most important devices and practices are bioretention BMPs consisting of swales, planters, and vegetated buffer strips, as well as detention BMPs consisting of rain gardens and infiltration trenches. While permeable paving also slows and retains streetwater, it is listed separately because its primary function is to serve as a surfacing material that reduces runoff. Additional tools include delivery and conveyance tools and inlet protections.

The streetwater management tools mentioned in this manual are highly customizable and can be integrated into a variety of different types of spaces in any of the street types. They can be implemented alone or in concert with one another to achieve cumulative benefits. Opportunity sites include medians, corner and midblock curb extensions, roadway and park edges, front building edges, and surrounding street trees. Selecting the appropriate BMP is very dependent on street type and site conditions. High traffic commercial streets have different parameters than smaller residential streets.

The following sections describe techniques to site and construct systems to integrate streetwater management tools into both new and existing streets. Table 12.1 below describes typical applicability of specific streetwater tools to individual street types.



**Table 12.1 Best Fit for Streetwater Tools by Street Context**

	STREET CONTEXT	BIORETENTION			DETENTION		PAVING	DELIVERY AND CONVEYANCE	INLET PROTECTIONS			
		Swales	Planters	Vegetated Buffer Strips and Retention Ponds	Rain Gardens	Infiltration Trenches and Detention Ponds	Permeable Paving	Channels and Runnels	Screens	Inlet Inserts	Pollution Control Boxes	Pipe Filters
Commercial	Downtown Commercial		0		0	0	0	0	0	0	0	0
	Commercial Throughway		0	0	0	0	0	0	0	0	0	0
	Neighborhood Commercial		0	0	0	0	0	0	0	0	0	0
Residential	Downtown Residential	0	0		0	0	0	0	0	0	0	0
	Residential Throughway	0	0		0	0	0	0	0	0	0	0
	Neighborhood Residential	0	0		0	0	0	0	0	0	0	0
Industrial And Mixed-Use	Industrial	0	0		0	0	0	0	0	0	0	0
	Mixed-Use		0	0	0	0	0	0	0	0	0	0
Special	Sidewalk Furniture Zone	0	0		0	0	0	0	0	0	0	0
	Park Edge	0	0		0	0	0	0	0	0	0	0
	Boulevard	0	0		0	0	0	0	0	0	0	0
	Ceremonial (Civic)						0	0	0	0	0	0
Small	Alley		0			0	0	0	0	0	0	0
	Shared Public Way		0			0	0	0	0	0	0	0



General Guidelines

**Site Considerations**

Streetscape geometry, topography, and climate determine the types of controls that can be implemented. The initial step in selecting a streetwater tool is determining the available open space and constraints. Although the maximum size of a selected streetwater facility may be determined by available area, the standard design storm should be used to determine the appropriate size, slope, and materials of each facility.

After identifying the appropriate streetwater facilities for a site, an integrated approach using several tools is encouraged. To increase water quality and functional hydrologic benefits, several streetwater management tools can be used in succession. This is called a treatment train approach. The control measures should be designed using available topography to take advantage of gravity for conveyance to and through each facility.

Traffic calming measures, such as medians, circles, chicanes, and curb extensions, should integrate streetwater management options discussed in this section. The first image to the right illustrates a center-draining street utilizing a rain garden integrated into a circle. These areas offer ideal opportunities for treating runoff as they typically intercept the flow path of water along a street and provide additional surface and subsurface space for treating and infiltrating streetwater. By integrating streetwater management tools at an early design stage, new facilities can be added with only marginal cost when paired with other streetscape construction projects. However, this idea should also be incorporated into street repaving projects.

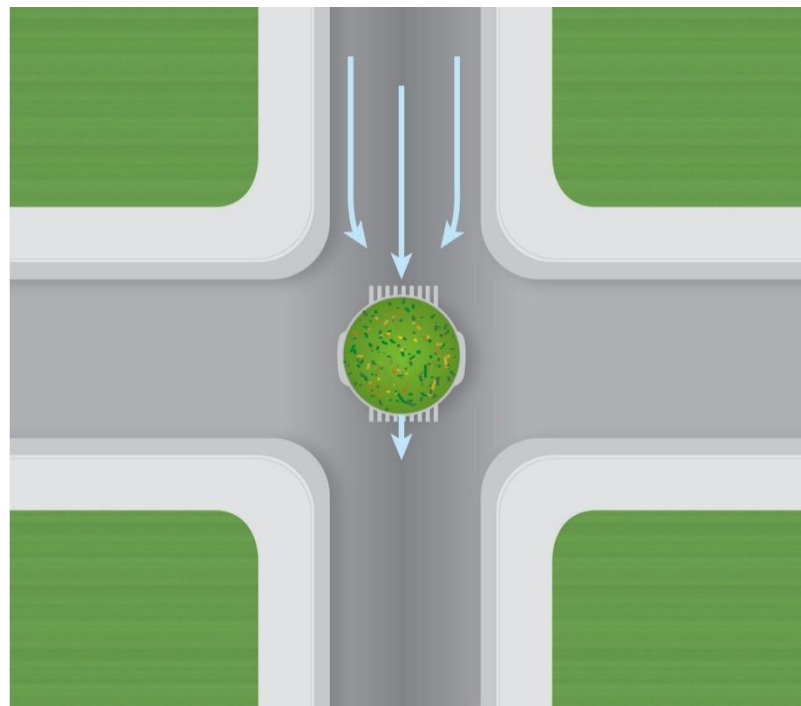

*Rain garden in rotary island  
 (Credit: Michele Weisbart)*

The image below illustrates a possible treatment on a traditional crowned street with traffic calming measures.

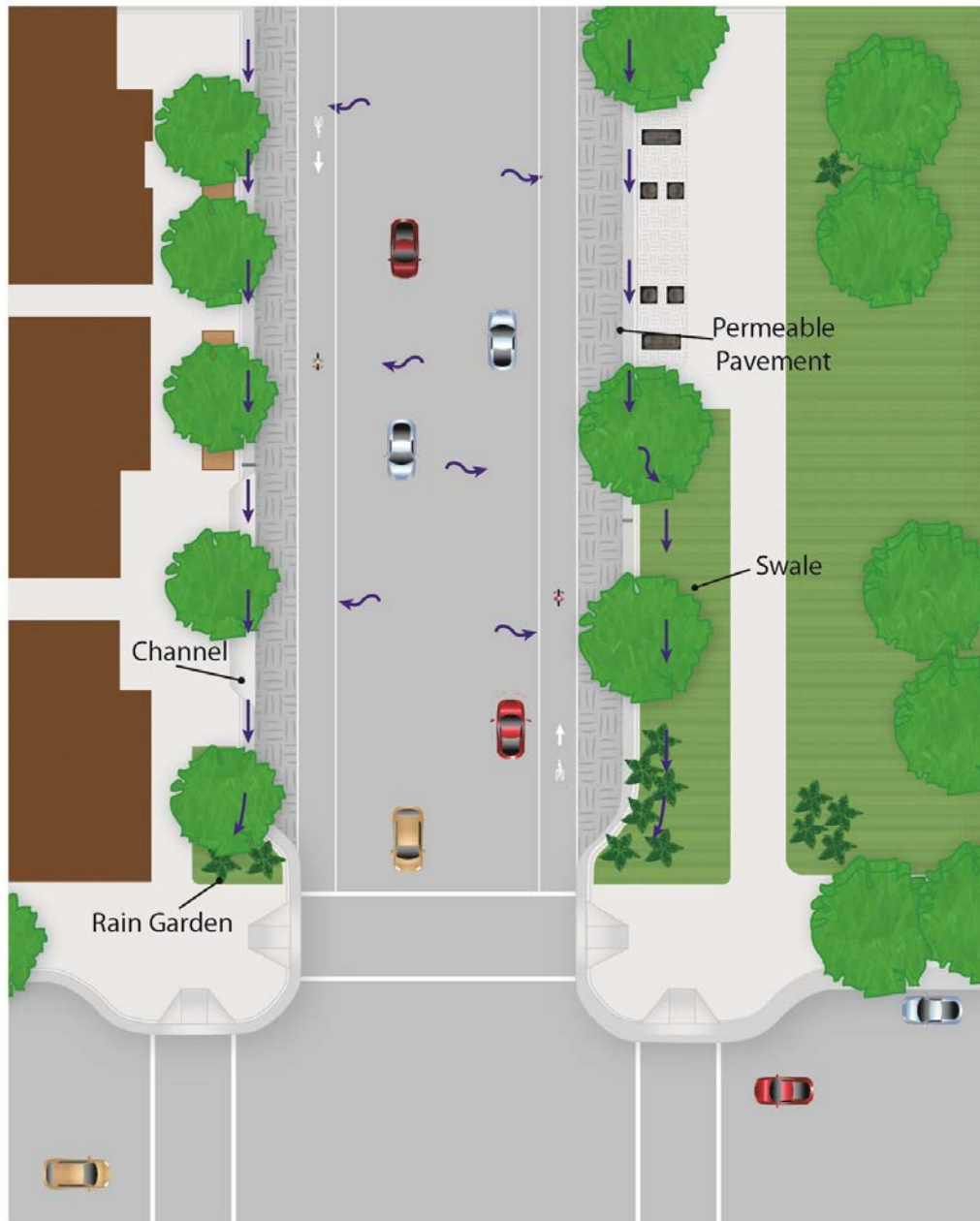

*Crowned complete street  
(Credit: Michele Weisbart)*

### **Infiltration Considerations**

Appropriate soils, infiltration media, and infiltration rates should be used for infiltration BMPs. Ideally, a complete geotechnical or soils report should be undertaken to determine infiltration rates, soil toxicity and stability, and other factors that will affect the ability and the desirability of infiltration. At a minimum, the infiltration capacity of the underlying soils



should be deemed suitable for infiltration and appropriate media should be used in the BMP itself.

Using certain techniques, streetwater tools can still be incorporated into areas of low permeability or where infiltration of stormwater is not desirable. Underdrains should be used in areas of low soil permeability. The location of the underdrain is an important consideration: if placed higher in a facility, the stored water below the perforated pipe will be infiltrated. If placed at the bottom of a sealed system, the perforated pipe will release the stored water slowly over time. These infiltration BMPs may overflow to appropriate locations such as catch basins and outfalls.

Details are important to the ultimate success or failure of an infiltration system. Poor soil conditions may cause stormwater to infiltrate either too fast or too slow. Over-compaction of subsurface soil during construction can lead to reduced infiltration capacity, flooding, and ponding. The bottom surface of infiltration areas should be level to allow even distribution. Soils and gravels in an infiltration installation should be meticulously specified and verified in the field during construction. Proper maintenance is crucial to the success of an infiltration BMP. To ensure proper caretaking, a maintenance plan or contract with a local agency is necessary.

### Bioretention



*Swale as Planter: Broward County  
(Credit: Pattie Gertenbach)*

Bioretention is a stormwater management process that cleans stormwater by mimicking natural soil filtration processes as water flows through a bioretention BMP. It incorporates mulch, soil pores, microbes, and vegetation to reduce and remove sediment and pollutants from stormwater. Bioretention is designed to slow, spread, and, to some extent, infiltrate water. Each component of the bioretention BMP is designed to assist in retaining water, evapotranspiration, and adsorption of pollutants into the soil matrix. As runoff passes

through the vegetation and soil, the combined effects of filtration, absorption, adsorption, and biological uptake of plants remove pollutants.

For areas with low permeability or other soil constraints, bioretention can be designed as a flow-through system with a barrier protecting streetwater from native soils. Bioretention



areas can be designed with an underdrain system that directs the treated runoff to infiltration areas, cisterns, or the storm drain system, or may treat the water exclusively through surface flow.

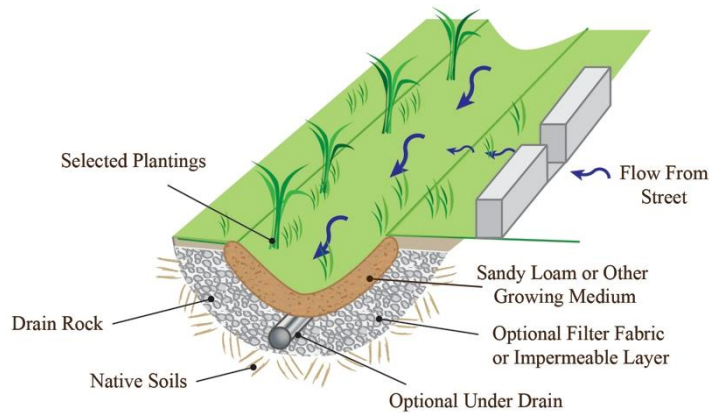

*Established swale in the landscape  
 (Credit: Julia Campbell and Michele Weisbart)*

Included in this section are discussions of swales, planters, and vegetated buffer strips.

**Location and Placement**

Bioretention facilities can be included in the design of all street components: adjacent to the traveled way and in the frontage or furniture sidewalk zones. They can be designed into curb extensions, medians, traffic circles, roundabouts, and any other landscaped area. Depending on the feature, maintenance and access should always be considered in locating the device. Bioretention systems are also appropriate in constrained locations where other stormwater facilities requiring more extensive subsurface materials are not feasible.



### Guidelines

A sponge-like surface application of organic mulch can quicken the rate of absorption into the soil, slow soil moisture loss to evaporation, and reduce the solid waste stream if the mulch is generated from local organic matter. This strategy can also intercept and reduce sediment and nutrient concentrations in runoff via bioremediation.

Plants should be microclimate-appropriate and must be able to tolerate occasional saturation as well as dry periods (see the Urban Forestry section of this chapter for planting recommendations).

The use of multiple small devices is often more feasible in tight urban environments than the use of one large device. Small systems can be linked together to achieve the desired cumulative capacity.

### Swales

Swales are linear, vegetated depressions that capture rainfall and runoff from adjacent surfaces. The swale bottom should have a gradual slope to convey water along its length. Swales can reduce off-site streetwater discharge and remove pollutants along the way. In a swale, water is slowed by traveling through vegetation on a relatively flat grade. This gives particulates time to settle out of the water while contaminants are removed by the vegetation. Because the vegetation receives much of its needed moisture through streetwater, the need for irrigation is greatly reduced.



*Sidewalk-adjacent swale during storm event*

*(Credit: Edward Belden, Los Angeles and San Gabriel Rivers Watershed Council)*



*Location and placement.* Swales can easily be located adjacent to roadways, sidewalks, or parking areas. Roadway runoff can be directed into swales via flush curbs or small evenly-spaced curb cuts into a raised curb. Swale systems can be integrated into traffic calming devices such as chicanes and curb extensions.

Swales can be placed in medians where the street drains to the median. Placed alongside streets and pathways, vegetated swales can be landscaped with native plants which filter sediment and pollutants and provide habitat for wildlife. Swales should be designed to work in conjunction with the street slope to maximize filtration and slowing of streetwater.

*Guidelines.* Soils that promote absorption and support vegetation, such as sandy loams, should be specified on a case-by-case basis. Base layers of rock and stabilizing filter fabric may also be specified. Swale length, width, depth, and slope should be determined by capacity needed for treatment of the design storm.

Swales are designed to allow water to slowly flow through. Depending on the landscape and design storm, an overflow or bypass for larger storm events may be needed. Curb openings should be designed to direct flow into the swale. Following the inlet, a sump may be built to capture sediment and debris. Mulch can be used in systems where it will not escape the swale system, such as in flatter, deeper swales. Check dams should be used to slow the velocity of water and catch sediment when the slope along the length of the swale exceeds 4 percent.

Swales should be landscaped with deep-rooted grasses and vegetation that tolerate short periods of inundation, deposits of sediment, and periods of drought. Vegetation will filter sediment and slow erosion, protecting the swale from failure. The sides of swales should be minimally sloped to protect the swale from erosion and slope failure.



Swale with curb cut opening and decorative grate outlet  
(Credit: AHBE Landscape Architects)

## Planters

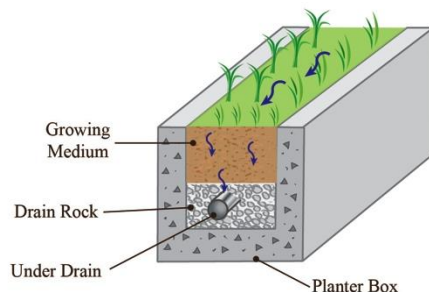

Planter detail  
(Credit: Julia Campbell and Michele Weisbart)

Planters are typically above-grade or at-grade with solid walls and a flow-through bottom. They are contained within an impermeable liner and use an underdrain to direct treated runoff back to the collection system. Where space permits, buildings can direct roof drains first to building-adjacent planters. Both underdrains and surface overflow drains are typically installed with building-adjacent planters.

At-grade street-adjacent planter boxes are systems designed to take street runoff and/or runoff from sidewalks and incorporate bioretention processes to treat stormwater.

These systems may or may not include underdrains.

*Location and placement.* Above-grade planters should be structurally separate from adjacent sidewalks to allow for future maintenance and structural stability per local department of public works' standards. At-grade planter systems can be installed adjacent to curbs within the frontage and/or furniture zones.



*Guidelines.* All planters should be designed to pond water for less than 48 hours after each storm. Flow-through planters designed to detain roof runoff can be integrated into a building's foundation walls, and may be either raised or at grade.

For at-grade planters, small localized depressions may be included in the curb opening to encourage flow into the planter. Following the inlet, a sump (depression) to capture sediment and debris may be integrated into the design to reduce sediment loadings.



*Planter along a downtown street  
(Credit: Kevin Robert Perry)*



### Vegetated Buffer Strips

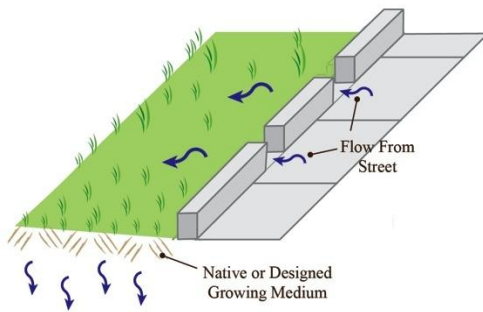

*Vegetated buffer strip detail  
 (Credit: Julia Campbell and  
 Michele Weisbart)*

Vegetated buffer strips are sloping planted areas designed to treat and absorb sheet flow from adjacent impervious surfaces. These strips are not intended to detain or retain water, only to treat it as a flow-through feature. They should not receive concentrated flow from swales or other surface features, or concentrated flow from pipes.

*Location and placement.* Vegetated buffer strips are well-suited to treating runoff from roads and highways, small parking lots, and pervious surfaces. They may be commonly used on multi-way boulevards, park edge streets, or sidewalk furniture zones with

sufficient space. Vegetated buffers can be situated so they serve as pre-treatment for another streetwater management feature, such as an infiltration BMP.

*Guidelines.* Buffer strips cannot treat large amounts of runoff; therefore, the maximum drainage width (with the direction of flow being towards the buffer) of the contributing drainage area should be 60 square feet. In general, a buffer strip should be at least 15 feet wide in the direction of flow to provide the highest water quality treatment.

The top of the strip should be set 2 to 5 inches below the adjacent pavement or contributing drainage area, so that vegetation and sediment accumulation at the edge of the strip does not prevent runoff from entering.

Buffer strips should be sited on gentle slopes. Steep slopes in excess of 15 percent may trigger erosion during heavy rain events, thus eliminating water quality benefits.

### Detention

Detention devices differ from retention in that they are designed and sized to hold a specific volume of water and then slowly release it over time. On the other hand, the bioretention BMPs described in the previous section are designed and sized based on flow—the rate of water passing through them. The objective of bioretention is to improve the quality of streetwater by promoting filtration and adsorption as water flows through vegetation and soil. Detention devices do not function as flow-through features, but rather the objective is to collect and contain water until it is removed by controlled release or infiltrated into the soil. Overflow outlets may be included to manage large storm events. Pollutants may be removed by vegetation and the topsoil layer as in bioretention BMPs so that streetwater is treated before it is infiltrated. Detention devices can greatly reduce the



volume of runoff from streetscapes and for small storm events may completely eliminate runoff.

### Rain Gardens

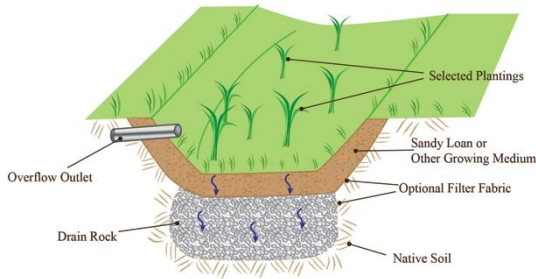

*Rain garden detail*

*(Credit: Julia Campbell and Michele Weisbart)*

through the topsoil and subsurface drain rock unless the volume of water is so large that some must overflow. Rain gardens can reduce or eliminate off-site streetwater discharge while increasing on-site recharge.

Rain gardens are shallow, vegetated depressions in the landscape that are planted with deep-rooted plants and grasses. Rain gardens can also be planted with native trees as space allows. This is especially desirable because one tree can reduce stormwater runoff by 4,000 gallons per year. Rain gardens have flat bottoms and gently sloping sides. Rain gardens can be similar in appearance to swales, but their footprints may be any shape. Rain gardens hold water on the surface, like a pond, and have overflow outlets. The detained water is infiltrated



*Rain garden in an urban landscape*

*(Credit: Kevin Robert Perry)*

**Location and placement.** Rain gardens may be placed where there is sufficient area in the landscape and where soils are suitable for infiltration. Rain gardens can be integrated with traffic calming measures installed along streets, such as medians, islands, circles, street



ends, chicanes, and curb extensions (pedestrian bulb-outs). Rain gardens are often used at the terminus of swales in the landscape.



*Rain garden: Portland, OR  
(Credit: Brad Lancaster, www.HarvestingRainwater.com)*

*Guidelines.* Native soils should have a minimum permeability rate of 0.5 inches per hour. Sites that have more than a 5 percent slope may require other stormwater management approaches or special engineering. The topsoil layer should be designed on a case-by-case basis and may often be a type of sandy loam. Subsurface drain rock will promote infiltration and should also be designed for each installation. Local public works departments may have additional guidelines for rain garden design.

The size and shape of rain gardens will vary in each case and the available area in the landscape may determine the maximum footprint. Because rain gardens are volume-based BMPs, their surface area and depth will be designed to achieve the desired detention volume. Overflow outlets should be below the lip of the rain garden and at a height consistent with the desired detention volume. Sides should be gently sloping to prevent erosion.

Rain gardens should be landscaped with deep-rooted grasses and other vegetation that can tolerate short periods of inundation, deposits of sediment, and periods of drought. According to the University of Florida IFAS Extension, suggested Florida rain garden



plantings include Loblolly Bay, Sweetbay Magnolia, Wax Myrtle, Cabbage Palm, Saw Palmetto, and Dahoon Holly.

### **Infiltration Trenches**

Infiltration trenches are linear, rock-filled features that promote infiltration by providing a high ratio of sub-surface void space in permeable soils. They provide on-site stormwater retention and may contribute to groundwater recharge. Infiltration trenches may accept streetwater from sheet flow, concentrated flow from a swale or other surface feature, or piped flow from a catch basin. Because they are not flow-through BMPs, infiltration trenches do not have outlets but may have overflow outlets for large storm events.

Infiltration trenches are typically designed to infiltrate all flow they receive. In large storm events, partial infiltration of runoff can be achieved by providing an overflow outlet. In these systems, significant or even complete volume reduction is possible in smaller storm events. During large storm events, these systems may function as detention facilities and provide a limited amount of retention and infiltration.

*Location and placement guidelines.* Infiltration trenches typically have small surface footprints so they are potentially some of the most flexible elements of landscape design. However, because they involve sub-surface excavation, these features may interfere with surrounding structures. Care needs to be taken to ensure that surrounding building foundations, pavement bases, and utilities are not damaged by infiltration features. Once structural soundness is ensured, infiltration features may be located under sidewalks and in sidewalk planting strips, curb extensions, roundabouts, and medians. When located in medians, they are most effective when the street is graded to drain to the median.

Infiltration features should be sited on uncompacted soils with acceptable infiltration capacity. They are best used where soil and topography allow for moderate to good infiltration rates (0.5 inches per hour) and the depth to groundwater is at least 10 feet. Prior to design of any retention or infiltration system, proper soil investigation and percolation testing should be conducted to determine appropriate infiltration design rates. Any site with potential for previous underground contamination should be investigated. Infiltration trenches can be designed as stand-alone systems when water quality is not a concern or may be combined in series with other streetwater tools.

*Pre-treatment, design, and installation guidelines.* Infiltration features do not treat streetwater and may become damaged by streetwater carrying high levels of sediment. In general, infiltration features should be designed in series with bioretention tools unless the infiltration features receive water from well-vegetated areas where sediment is not expected. Pre-treatment features should be designed to treat street runoff prior to discharging to infiltration features. Bioretention devices, sumps, and sedimentation basins are several pre-treatment tools effective at removing sediment.



Trenches are typically backfilled with coarse drain rock (coarse gravel) and may or may not be lined with filter fabric. Additional void space can be achieved by including materials such as perforated pipes, half pipes, or open blocks within the drain rock. The trench surface can be planted, covered with grating, covered with boardwalks, or simply remain as exposed drain rock. Local public works departments should be contacted for any local guidance on infiltration feature design.

The slope of the infiltration trench bottom should be designed to be level or with a maximum slope of 1 percent. Infiltration BMPs should be installed parallel to contours with maximum ground slopes of 20 percent and be located no closer than 5 feet to any building structure. Sub-soils should not be compacted. Drain rock and, if needed, filter fabric with an overflow drain should be designed for each installation.

Perforated pipes and piped inlets and outlets may be included in the design of infiltration trenches. Cleanouts should be installed at both ends of any piping, and at regular intervals in long sections of piping, to allow access to the system. Monitoring wells are recommended for both trenches and wells and can be combined with clean-outs. If included, the overflow inlet from the infiltration trench should be properly designed for anticipated flows.



*Infiltration trench with perforated pipe during installation  
(Credit: Neil Shapiro)*

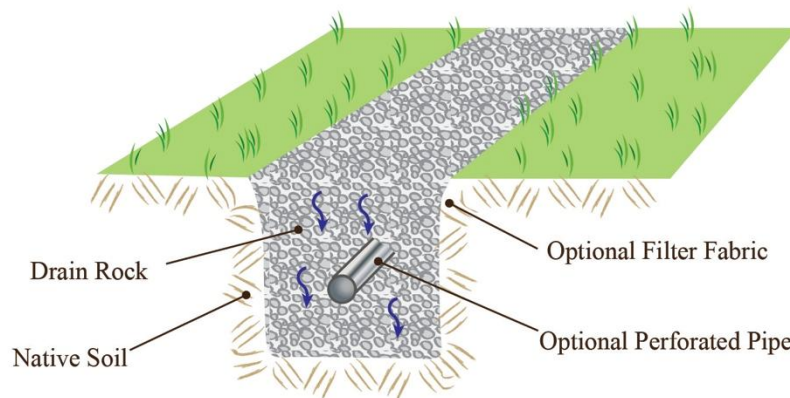

*Infiltration trench  
 (Credit: Julia Campbell and Michele Weisbart)*

Paving

**Permeable Paving**

Permeable paving is a system with the primary purpose of slowing or eliminating direct runoff by absorbing rainfall and allowing it to infiltrate into the soil. This BMP is impaired by sediment-laden run-on which diminishes its porosity. Care should be taken to avoid flows from landscaped areas reaching permeable paving. In those cases, bioretention is a better choice for BMPs. Permeable paving is, in certain situations, an alternative to standard paving. Conventional paving is designed to move streetwater off-site quickly. Permeable paving, alternatively, accepts the water where it falls, minimizing the need for management facilities downstream.

Permeable paving

- Filters and cleans pollutants such as petroleum deposits on streets
- Reduces water volumes for existing overtaxed pipe systems
- Decreases the cost of offsite or onsite downstream infrastructure

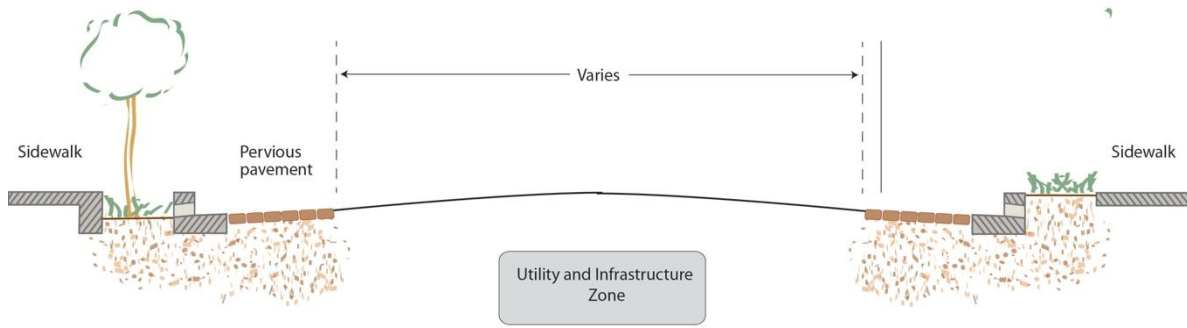

Street section elevation illustrating placement of pervious pavement  
(Credit: Marty Bruinsma)



Permeable pavement after a rain event  
(Credit: Neil Shapiro)



*Location and placement guidelines.* Conditions where permeable paving should be encouraged include:

- Sites where there is limited space in the right-of-way for other BMPs
- Parking or emergency access lanes
- Furniture zones of sidewalks especially adjacent to tree wells

Conditions where permeable paving should be avoided include:

- Where runoff is already being harvested from an impervious surface for direct use, such as irrigation of bioretention landscape areas
- Steep streets
- Large traffic volume or heavy load lanes
- Gas stations, car washes, auto repair, and other sites/sources of possible chemical contamination
- Areas with shallow groundwater
- Within 20 feet of sub-sidewalk basements
- Within 50 feet of domestic water wells

*Material guidelines.* When used as a road paving, pervious pavement that carries light traffic loads typically has a thick drain rock base material. Pavers should be concrete as opposed to brick or other light-duty materials. Other possible permeable paving materials include porous concrete and porous asphalt. These surfaces also have specific base materials that detain infiltrated water and provide structure for the road surface. Base material depths should be specified based on design load and the soils report.

Plazas, emergency roads, and other areas of limited vehicular access can also be paved with permeable pavement. Paving materials for these areas may include open cell paver blocks filled with stones or grass and plastic cell systems. Base material specifications may vary depending on the product used, design load, and underlying soils.

When used for pedestrian paths, sidewalks, and shared-use paths, appropriate materials include those listed above as well as rubber pavers and decomposed granite or something similar (washed of pore-clogging fine material). Pedestrian paths may also use broken concrete pavers provided ADA requirements are met. Paths should drain into adjoining landscapes and should be higher than adjoining landscapes to prevent run-on. Soil paths are not successful on slopes in excess of 4 percent. Any pervious materials used for sidewalks or paths should be very smooth for wheelchairs and bicyclists.



*Permeable paving and a trench drain in a parking area  
(Credit: Stephanie Landregan)*

*Design guidelines.* Design considerations for permeable paving include:

- The location, slope and load-bearing capacity of the street.
- The infiltration rate of the soil.
- The amount of storage capacity of the base course.
- The traffic volume and load from heavy vehicles.
- The design storm volume calculations and the quality of water.
- Drain rock, filter fabrics, and other subsurface materials.
- Installation procedures including excavation.

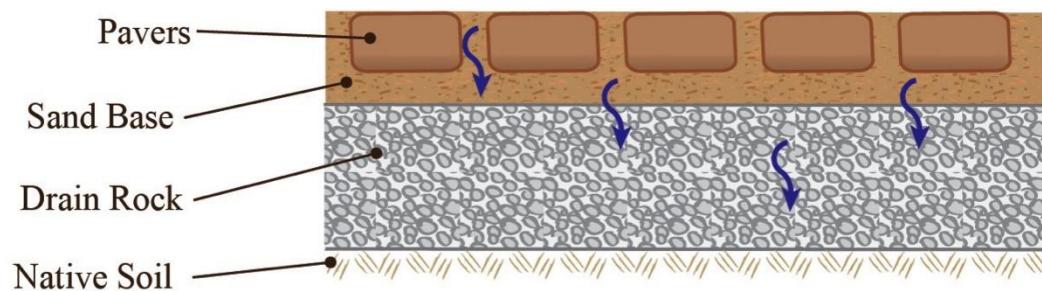

*Pervious pavement detail  
(Credit: Julia Campbell and Michele Weisbart)*

A soil or geotechnical report should be conducted to provide information about the permeability and load-bearing capacity of the soil. Infiltration rate and load capacity are



key factors in the functionality of this BMP. Permeable paving generally does not have the same load-bearing capacity as conventional paving, so this BMP may have limited applications depending on the underlying soil strength and paving use. Permeable paving should not be used in general traffic lanes due to the possible variety of vehicles weights and heavy volumes of traffic.

The soil report should also provide the depth of the water table to determine if permeable pavers are an appropriate application for the site. Pervious pavement typically requires a 4-foot or more separation from the water table or bedrock to properly infiltrate streetwater. Pervious pavement is not recommended over new or compacted fill.

Because permeable pavement is damaged by sediment deposits, it should be carefully placed in the landscape so as to avoid run-on, especially from sediment-laden sources such as landscaped areas.

Pavement used for sidewalks and pedestrian paths should be ADA compliant, especially smooth, and not exceed a 2 percent slope or have gaps wider than 0.25 inches. In general, tripping hazards should be avoided.

*Maintenance and installation guidelines.* Proper construction and installation of permeable pavement is vital to its success. To ensure that the paving system functions properly, sub-base preparation and stormwater pollution prevention measures should be performed appropriately during installation.

Construction considerations include:

- Scarifying soils so that they remain porous.
- Avoiding compaction of soils.
- Preventing run-on and sedimentation during construction.

Maintenance of permeable pavement systems is essential to their continued functionality. Regular vacuuming and street sweeping should be performed to remove sediment from the pavement surface. The bedding and base material should be tested to ensure continued sufficient infiltration rates on a regular basis. Additionally, base material may need to be removed and replaced every several years based upon the material manufacturer's specifications.

#### Delivery and Conveyance

Water conveyance measures in the hardscape may support the treatment BMPs outlined above. By daylighting streetwater flow, these measures draw attention to water movement and can in turn highlight bioretention and detention BMPs. Delivery and conveyance measures do not treat streetwater for quality and do not reduce water



volume. They are therefore only recommended as supporting infrastructure, a preferable alternative to traditional piped flow.

### **Channels, Runnels, Trench Drains, and Constructed Swales**

Channels, runnels, trench drains, and constructed swales are conventional methods of conveying moderate amounts of streetwater from buildings and impervious surfaces to other drainage collection systems, streets, or planters. They are hardscape features constructed from impermeable materials.

Typically, these structures work well where there is a need for water redirection and space is limited. These hardscape methods may serve to move streetwater from the street to landscaped areas. Channels and constructed swales are not used for stormwater treatment but serve as daylighted, visible conveyance features in lieu of closed pipe systems. They provide opportunities to acknowledge natural drainage processes with artistic design features along the drainage path.

A variety of materials can be used for channels, runnels, and constructed swales: stone, brick, pebbles, pavers, and concrete. Rock swales can be created by arranging stones loosely and mortaring them in place. When a closed top is required, grates can be constructed; proprietary products in standard sizes are readily available. Decorative grates are aesthetic and help illustrate water flow processes.

Because these structures are gravity fed, they require slopes to function properly. On slopes greater than 6 percent, check dams or other velocity reduction devices should be provided.

These conveyance features may direct sheet flow to bioretention or infiltration features or simply serve as an alternative to piped flow in conventional drainage systems. Dimensions should be determined based on the design storm.

Channels have vertical sides and provide a drainage path to a downstream streetwater management feature. Channels vary in depth depending on the amount of flow they are designed to carry, have a sloped bottom, and can be covered or open. In some cases, channels can be constructed with pervious bottoms. Channels can be placed in plazas, driveways, and other hardscapes where conveyance is needed. Channels may be used in some situations where swales or pipes would be too costly or impossible due to site constraints. In broad landscape contexts, channels can be large and constructed to carry large volumes of water.

Runnels are shallower than channels, typically only a couple of inches deep, and are designed to carry small flows of streetwater. Runnels may have an open top but must be covered if they cross pedestrian walkways. Most often runnels are used to convey runoff from hardscapes to adjacent streetwater treatment landscapes. Runnels may be very useful in pedestrian hardscape areas where artistic construction is highly visible. The



location and design of runnels should be carefully selected so that they do not pose tripping hazards.



*Decorative runnel and fountain  
(Credit: Stephanie Landregan)*

Trench drains are a type of conveyance system similar to runnels. Trench drains differ from runnels in that they are usually smaller and have a grated top. They also have solid sides and bottoms. Trench drains are available in standard sizes and dimensions from a variety of manufacturers.



*Trench drain in hardscape  
(Credit: Stephanie Landregan)*



Constructed swales are similar to the swales discussed earlier but are constructed from impervious materials. They typically are long narrow depressions used to convey water. The size of a swale should be determined by the design storm and landscape features.



*Constructed swale with drain  
(Credit: Stephanie Landregan)*

*Access, design, and maintenance guidelines.* All conveyance structures, both open and covered, need to meet accessibility guidelines when in the path of travel. Boardwalks can cover large swales, or decorative grates can be used over smaller widths.

Channels, runnels, and constructed swales should be designed to meet the local agency design storm requirements. Overflow features may be required in some areas and should drain to the nearest gutter or other drainage feature, always draining away from adjacent properties. These features should be designed to allow debris to move through them and account for stoppages that could limit the drainage capacity.

Maintaining a clear conduit is essential for the proper functioning of conveyance structures. These features should be cleaned before the rainy season and checked before and after storm events. Trash, cigarette butts, soil sediment, and leaf litter all can contribute to failure and decrease the function of these features.



Storm Drain Inlet Protections: Retrofitting Existing Storm Drains

Existing storm drain systems may be retrofitted to improve streetwater quality without costly capital improvements. The BMPs described below can be used with existing conventional piped storm drain systems to address water quality but not water volume concerns. The measures described below are designed to prevent particulates, debris, metals, and petroleum-based materials conveyed by streetwater from entering the storm drain system. All storm drain protection units should have an overflow system that allows the storm drain to remain functional if the filtration system becomes clogged during rainstorms.

Typical maintenance of catch basins includes scheduled trash removal if a screen or other debris capturing device is used. Street sweeping should be performed by vacuum sweepers with occasional weed and large debris removal. Maintenance should include keeping a log of the amount of sediment collected and the data of removal. Some local jurisdictions have incorporated the use of GIS systems to track sediment collection and to optimize future catch basin cleaning efforts. Bulb-outs should be designed with two return curves with a radius of over 10 feet to allow street sweepers to clean the corners.

All inlet tools located in the pedestrian access route should conform to ADA requirements.



*Curb inlet grate catching debris  
 (Credit: Andre Haghverdian)*

**Storm Drain Inlet Screens: Placement and Guidelines**

Inlet screens are designed to prevent large litter and trash from entering the storm drain system while allowing smaller particles to pass through. The screens function as the first preventive measure in removing pollutants from the storm water system. Storm drain inlet



screens can be designed and fabricated on an as-needed basis; proprietary screens are readily available for standard size inlets.

Inlet screens are external units mounted on existing curb side storm drain catch basins. The unit captures bigger particles and allows the storm water and small particles to pass through. The screen can be mounted on hinges to create a bypass if the screen is clogged during a storm.

A wide range of storm drain inlet screens is available. The city's street sweeping department should be consulted to ensure compliance with local specifications and to schedule regular maintenance. Annual inspection of the screen is recommended to ensure functionality.

#### **Storm Drain Inlet Protection: Placement and Guidelines**

The inlet protection should be designed to protect curbside catch basins or inlets within the traveled way. Inlet inserts contain filter cartridges that can be easily replaced.

The inlet protection can be installed on the existing wall of the catch basin. It can be placed on the curb side wall of catch basins so that during storm events water can overflow around the unit.

Inlet inserts should be sized to capture all debris and should therefore be selected to match the specific size and shape of each catch basin and inlet. Maintenance should be taken into account—systems with lower maintenance requirements are preferred.

#### **Storm Drain Pipe Filter: Placement and Guidelines**

The storm drain outlet pipe protection or filter is designed to be installed on an existing outlet pipe or at the bottom of an existing catch basin with an overflow. This filter removes debris, particulates, and other pollutants from streetwater as it leaves the storm drain system. This BMP is less desirable than a protection system that prevents debris from entering the storm drain system because the system may become clogged with debris.

Outlet pipe filters can be placed on existing curbside catch basins and flush grate openings. Regular maintenance is required and inspection should be performed rigorously. Because this filter is located at the outlet of a storm drain system, clogging with debris is not as apparent as with filters at street level. This BMP may be used as a supplemental filter with an inlet screen or inlet insert unit.



## URBAN FORESTRY

The urban forest includes all trees, shrubs, and other understory plantings on both public and private lands. Street trees and landscaping are essential parts of the urban forest, as they contribute positively to the urban environment—to climate control, stormwater collection, and the comfort and safety of people who live or travel along the street. A street lined with trees and other plantings looks and feels narrower and more enclosed, which encourages drivers to slow down and to pay more attention to their surroundings. Trees provide a physical and a psychological barrier between pedestrians and motorized traffic, increasing safety as well as making walking more enjoyable.

A healthy urban forest is also a powerful streetwater management tool. Leaves and branches catch and slow rain as it falls, helping it to soak into the ground. The plants themselves take up and store large quantities of water that would otherwise contribute to surface runoff. Part of this moisture is then returned to the air through evaporation to further cool the city.

As an important element along sidewalks, street trees must be provided with conditions that allow them to thrive, including adequate uncompacted soil, water, and air. This section provides guidance for appropriate conditions and selecting, planting, and caring for street trees, as well as for other landscaping along streets.



*Urban forest of street trees on a residential street in Fort Lauderdale  
(Credit: Kimley-Horn and Associates, Inc.)*

## STREET TREES

### Goals and Benefits of Street Trees

The goal of adding street trees is to increase the canopy cover of the street, the percentage of the streets surface either covered by or shaded by vegetation, not simply to increase the overall number of trees. The selection, placement, and management of all



elements in the street should enhance the longevity of a city's street trees and healthy, mature plantings should be retained and protected whenever possible.

Street trees purify and cool the air, reduce stormwater runoff, and conserve energy. Additional related benefits of street trees include increased property values, neighborhood beautification, and enhanced human health and well-being. According to [www.rootfortrees.org](http://www.rootfortrees.org), street tree benefits are directly related to tree size. The environmental benefits of trees arise from respiration and transpiration, which are the biological processes by which trees breathe and absorb water from the environment. Because these processes involve interactions between a tree's leaves, the environment, and the atmosphere, the benefits increase as trees grow in size.

A large tree will yield \$48 to \$62 in average annual net benefits over 40 years with costs factored in (McPherson, G. et al, "Tree Guidelines for San Joaquin Valley Communities," Western Center for Urban Forest Research and Education, USDA Forest Service, 1999). Adding street trees provides the following benefits.



*Appropriate local street trees  
 (Credit: Kimley-Horn and Associates, Inc.)*

- Creates shade to lower temperatures in a city, reduces energy use, and makes the street a more pleasant place in which to walk and spend time
- Slows and captures rainwater, helping it soak into the ground to restore local hydrologic functions and aquifers
- Improves air quality by cooling air, producing oxygen, and absorbing and storing carbon in woody plant tissues
- Increases property values and sales revenues for existing businesses
- Enhances local neighborhood and cultural identity through specific plant forms and materials, the act of planting and sharing food crops, or by creating sheltering spaces for social interaction
- Enhances safety and personal security on a street by calming traffic and by fostering a denser and more consistent human presence, also referred to as eyes on the street
- Provides cover, food, and nesting sites for indigenous wildlife as well as facilitates habitat connectivity



### Principles for Street Trees

The following principles influence the selection of street trees and landscaping design:

- **Seek out and reclaim space for trees.** Streets have a surprising number of residual or left-over spaces between areas required for travel lanes and parking, once they are examined from this perspective. Traffic circles, medians, channelization islands, and curb extensions can provide space for trees and landscaping.
- **Create optimum conditions for growth.** Space for roots and above ground growth is the main constraint to the urban forest achieving its highest potential. Typically a 6 to 8-foot wide, continuous sidewalk furniture zone must be provided, with uncompacted soil to a minimum of a 3-foot depth. If space for trees is constrained, provisions should be made to connect these smaller areas below the surface to form larger effective areas for the movement of air, root systems, and water through the soil.
- **Select the right tree for the space.** In choosing a street tree, consider what canopy, form, and height will maximize benefits over the course of its life. Provide necessary clearances below overhead high-intensity electrical transmission lines and prevent limbs from overhanging potentially sensitive structures such as flat roofs. In commercial areas where the visibility of façade-mounted signs is a concern, choose species whose mature canopy allows for visibility, with the lowest branches at a height of 12 to 14 feet or more above the ground. Select trees with non-aggressive root systems to avoid damaging paving and sidewalks.
- **Start with good nursery stock and train it well.** When installing plant material, choose plants that have complete single leaders and are in good "form," and check that boxed trees are not root bound. Proper watering and pruning every three to four years will allow trees to mature and thrive for many years of service.
- **Do not subject plants to concentrated levels of pollutants.** Trees and other plants should be integrated within streetwater management practices whenever possible, but filtering of pollutants from "first flush" rain falls and street runoff will extend the life of trees and prevent toxic buildup of street pollutants in tree wells.

### Guidelines

#### **Climate and Soil**

Selecting trees that are adapted to a site's climate and local rain cycles can create a more sustainable urban forest. The urban environment is harsh for many plants. Often plants native to an area are best adapted to that area's climate. Select plants that can tolerate the environmental elements, such as radiant heat from the sidewalk or street surface or 50 to 60 mph winds from passing traffic.

Urban soils have become highly compacted through construction activities and the passage of vehicle and even foot traffic. Compaction reduces the soil's capacity to hold and absorb water. Plants need healthy soil, air, and water to thrive.



Using planters in the urban forest can increase the biomass and canopy cover, but these plants and trees are still compromised and confined. At its bottom and sides a barrier will exist as the prepared area meets the surrounding compacted soils. Covering the soil surface with some form of mulch can help as the shade, cooling, and retained moisture that mulch provides help support the biological activities close to the soil's surface. These activities open the pore structure of the soil over time, help keep it open, and cushion the impact of foot traffic. This process works better if the mulch material is organic, as opposed to stones. If planters have limited resources for soil preparation they should have an extensive covering of mulch.

The generalized soil types map for a city can be used as a starting point when planning projects, but then the basic soil classifications should be identified on-site, especially when confronted by planting sites at the extreme ends of the spectrum: very fast-draining, nutrient-poor sands and dense, often nutrient-rich but oxygen-starved poorly drained clays.



*Street trees (Credit: Kimley-Horn and Associates, Inc.)*

### **Planting Sites**

Traditionally, trees have been squeezed into whatever limited space is easily found, but this does not work well for either the tree or the street. The following guidelines provide recommended planting areas:

- Establish and maintain 6 to 8-foot wide sidewalk furniture zones where possible. Many large trees need up to 12 feet in width, and are not suitable for placement in



narrower furniture zones. In residential areas, sidewalk furniture zones within the root zone should be unpaved and planted/surfaced with low groundcover, mulch, or stabilized decomposed granite where these can be maintained. Where maintenance of such extensive sidewalk furniture zones is not feasible, provide 12-foot long tree wells with true permeable pavers (standard interlocking pavers are not permeable).

- If the above conditions are not feasible, provide for the tree's root system an adequate volume of uncompacted soil or structural or gap-graded soil (angular rock with soil-filled gaps) to a depth of 3 feet under the entire sidewalk (in the furniture, frontage, and pedestrian sidewalk zones).
- Spacing between trees will vary with species and site conditions. The spacing should be 10 percent less than the mature canopy spread. Closer spacing of large canopy trees is encouraged to create a lacing of canopy, as trees in groups or groves can create a more favorable microclimate for tree growth than is experienced by isolated trees exposed to heat and desiccation from all sides. On residential streets where lots are 40 or 50 feet wide, plant one tree minimum per lot between driveways. Where constraints prevent an even spacing of trees, it is preferable to place a tree slightly off the desired rhythm than to leave a gap in the pattern.
- Planting sites should be graded, but not overly compacted, so that the soil surface slopes downward toward the center, forming a shallow swale to collect water. The crown of the tree should remain 2 inches above finished grade and not be in the center of a swale, but off to the side. The finished soil elevation after planting is held below that of the surrounding paving so 2 to 3 inches of mulch can be added. The mulch layer must be replenished as needed to maintain a nearly continuous level surface adjacent to paving.
- Generally tree grates and guards are best used along streets with heavy pedestrian traffic. Along streets without heavy foot traffic and in less urban environments, use mulch in lieu of tree grates.

### Species Selection

- Select trees with non-aggressive root systems to avoid damaging pavement and sidewalks.
- In general, street trees should be species that will achieve a height and spread of 50 feet on residential streets and 40 feet on commercial streets within 10 years of planting to provide reasonable benefits. Typically, trees on commercial streets will not achieve the same scale as they will on residential streets where greater effective root zone volumes may be achieved. On commercial streets with existing multi-story buildings and narrow sidewalks, select trees with a narrower canopy than can be accommodated on the limited sidewalk width.
- Local jurisdictions should establish a list of recommended tree species for use in the public street rights-of-way. In Broward County, drought-tolerant native trees with large canopies should be utilized where possible. Coordination with the



University of Florida Institute of Food and Agricultural Sciences (IFAS) Extension Service (UF-IFAS Broward County Extension Office) should be conducted. For example, large trees may include palms, live oaks, gumbo limbo, mahogany, and paradise tree. Medium trees may include satin leaf, pigeon plum, bay cedar, Geiger, and red maple. (Note that dry weather runoff should not be directed to oaks and other trees that are not tolerant of dry season irrigation.) On commercial streets with ground-floor retail, deciduous trees with a strong central leader, such as Ginkos and London Planes, are desirable as they grow rapidly above the ground floor business signs. A city's list of recommended tree species should specify minimum planting site widths for each and which trees may be planted below overhead utility lines. Where there are overhead power lines that are less than 50 feet above grade, braided insulated electrical wire should be used so that trees do not have to be pruned to avoid the electrical lines. If braided insulated electrical wire cannot be provided, appropriate trees that will not grow tall enough to reach the power lines should be specified and planted.

- Trees that are part of streetwater management practices must be species that respond well to the extremes of periodic inundation and dry conditions found in water catchment areas. Design of all planting areas should include provisions for improved streetwater detention and infiltration.
- Consistent use of a single species helps reinforce the character of a street or district, but a diversity of species may help the urban canopy resist disease or insect infestations. New plantings added to streets with existing trees should be selected with the aim of meeting the same watering requirements and creating visual harmony with existing trees and plantings. Native species should be considered for inclusion whenever possible, but consideration should be first given to a species' adaptability to urban conditions.
- Consider deciduous species where their ability to allow sunlight to penetrate into otherwise shaded areas (such as south facing windows of adjoining buildings) during the winter months will be a plus.



*NatureScape Broward provides information on selecting plants species for Florida-friendly landscapes that preserve water, protect water quality, and create wildlife habitat  
 (Credit: Broward County, NatureScape Broward  
<http://www.broward.org/NaturalResources/NatureScape/Pages/Default.aspx>)*



### Tree Spacing and Other Considerations

- See Chapter 5, “Traveled Way Design,” for an understanding of how to take intersection sight distance into account when designing intersections. Many jurisdictions have tree spacing requirements at intersections, which typically vary from 30 to 45 feet, to provide visibility at corners. But as discussed in Chapter 5, this distance can often be reduced with no compromise in safety in slow speed environments.
- Most jurisdictions have spacing requirements between trees and street lights (typically about 30 feet high), which typically vary from 10 to 20 feet. The smaller setback provides greater flexibility in tree spacing and allows for a more complete tree canopy.
- Pedestrian lights, which are about 12 feet tall, generally do not conflict with the tree canopy, so spacing is less rigid. Some jurisdictions still require wide clearance for their convenience in maintaining the lights, but this wide spacing greatly reduces tree canopy and is therefore discouraged. Spacing of 10 feet away from trees is generally adequate.
- An 8-foot minimum clearance must be maintained between accessible parking spaces and trees.
- Trees may be planted as close as 6 feet from bus shelters, where they provide welcoming shade at transit stops.
- Adequate clear space should be provided between trees and awnings, canopies, balconies, and signs so they will not come into conflict through normal growth or require excessive pruning to remediate such conflicts.
- Trees may be planted in medians that are 4 feet or wider, but must have an adequate clear height between the surface of the median and the lowest branches so that pedestrians can be seen. Where trees hang over the street, the clear height should be 14 feet.

### UNDERSTORY LANDSCAPING

Understory landscaping refers to landscape elements beneath the tree canopy in areas within the public right-of-way not required for vehicular or pedestrian movement, including

- Medians
- Curb extensions
- Furniture and frontage zones

### Benefits of Understory Landscaping

- Complements and supports street trees, in particular by providing uncompacted, permeable areas that accommodate roots and provide air, water, and nutrients.



- Reduces impervious area and surface runoff.
- Treats stormwater, improving water quality .
- Provides infiltration and groundwater recharge.
- Provides habitat.
- Reduces the perceived width of the street by breaking up wide expanses of paving, particularly when the understory is in medians and sidewalk furniture zones.
- Contributes to traffic calming.
- Provides a buffer between the walkway zone and the street, contributing to pedestrian comfort.
- Improves the curb appeal of properties along the street, potentially increasing their value.
- Enhances the visual quality of the community.

### Principles

- Trees take precedence: the understory landscape should support them. It should not compete with them.
- Only pave where necessary: keep as much of the right-of-way unpaved and planted as possible to maximize benefits
- Design understory areas to infiltrate water
- The entire understory area does not have to be covered with plants—composted mulch is a good groundcover (top of mulch should be below adjoining hardscape so that runoff will flow into planning areas).
- Make the understory sustainable: use drought-tolerant plants
- Replenish the soil with compost
- Design the understory to contribute to the sense of place

### Guidelines

#### **Soil**

Provide good quality, uncompacted, permeable soil. Soil analyses should address the concentration of elements that may affect plant growth, such as pH, salinity, infiltration rate, etc. Remove and replace or amend soil as needed. Good preparation saves money in the long run because it reduces the need to replace plants, lowers water consumption, and reduces fertilizer applications.



*Landscaped shared-use path in Coconut Creek  
(Credit: Kimley-Horn and Associates, Inc.)*

### **Design**

Generally, understory landscaped areas should be as wide as possible where there are trees: when feasible, at least 6 to 9 feet wide for parkways and 8 to 12 feet wide for medians. However, many existing parkways and medians are less wide. Narrower parkways can support understory plants and some tree species. A path or multiple paths should be added as needed across a parkway as a means of access from the curb to the sidewalk. For example, where there are striped curbside parking spaces, a path across the parkway should be provided at every one or two parking spaces.



*Walking path across understory landscaping provides access from parked cars to sidewalk  
(Credit: Patricia Smith)*

Plant with species that

- Do not require mowing more frequently than once every few months
- Are drought tolerant and can survive with minimal irrigation upon establishment
- Do not exceed a height of 2 feet within 5 feet of a driveway/curb cut and within 20 feet of a crosswalk, and, excluding trees, 3 feet elsewhere
- Do not have thorns or sharp edges adjacent to any walkway or curb
- Are located at least 4 feet from any tree trunk

## STREET FURNITURE

Street furnishings in the street environment add vitality to the pedestrian experience and recognize the importance of the pedestrian to the fabric of a vibrant urban environment. Street furnishings encourage use of the street by pedestrians and provide a more comfortable environment for non-motorized travel. They provide a functional service to the user and provide uniformity to the urban design. Street furnishings include benches and seating, bollards, flower stands, kiosks, news racks, public art, sidewalk restrooms, signs, refuse receptacles, parking meters, and other elements.

Street furnishings achieve improved vitality in many ways:

- They make walking, bicycling, and public transit more inviting.
- They improve the street economy and common city prosperity.
- They enhance public space and create a place for social interaction.



Placement of street furnishings should be provided:

- At concentrations of pedestrian activity (nodes, gathering areas).
- On streets with pedestrian-oriented destinations. Pedestrians may gather or linger and enjoy the public space.
- Site furnishing placement should follow these criteria :
  - Street furnishings are secondary to the layout of street trees and light standards as street trees and light standards develop a street rhythm and pattern. Site furnishing should be placed in relation to these elements sensitive to the vehicular flow and pedestrian use of these elements. Careful consideration to the placement provides ease of recognition and use.
  - In addition to the guidelines provided for each element, placement should adhere to the minimum spacing. Site furnishing installed within the appropriate zone will be spaced not less than as shown in Table 12.2.

**Table 12.2 Site Furnishing Minimum Setbacks**

Location	Setback
Face of Curb	18"
Driveway	2'
Wheelchair Ramp	2'
Ramp Landing	4'
Fire Hydrant	5'
Stand Pipe	2'
Transit Shelter	4'

- All site furnishing must be accessible per Public Rights-of-Way Accessibility Guidelines (PROWAG) and other city regulations.
- Local jurisdictions should strive to include sustainable materials for street furnishings.

### BENCHES AND SEATING

Public seating provides a comfortable, utilitarian, and active environment where people can rest, socialize, or read in a public space. The proper placement of a bench is a simple gesture creating a sense of place for the immediate area.



*Street Furniture on a wide sidewalk  
(Credit: Kimley-Horn and Associates, Inc.)*

### Location

Seating arrangements should be located and configured according to the following guidelines:

- Seating should be located in a shaded area under trees.
- Seating should be oriented toward points of interest; this can be the adjacent building, an open space, or the street itself if it's lively. Where sidewalk width permits, seating can also be oriented perpendicular to the curb.
- Informal seating opportunities, incorporated into the adjacent building architecture, may be used as an alternative to free-standing benches. Low planter walls can be used as informal seating areas.

### Design

Benches and seating should be made of durable high-quality materials. The seating design should complement and visually reinforce the design of the streetscape.

Seating opportunities should be integrated with other streetscape elements.



## BOLLARDS

Bollards are primarily safety elements to separate pedestrians or other non-motorized traffic from vehicles. Thoughtful design and/or location of bollards can add interest, visually strengthen street character, and define pedestrian spaces.



*Bollards separate a street-end from the sidewalk  
(Credit: Kimley-Horn and Associates, Inc.)*

### Location

Bollards are used to prevent vehicle access on sidewalks, or on other areas closed to motor vehicles. Removable bollards should be placed at entrances to permanent or temporary street closures.

### Design

Bollards range in size from 4 to 10 inches in diameter. Bollards should have articulated sides and tops to provide distinct design details. The details should be coordinated with other street elements of similar architectural character.

Removable bollards should be designed with a sturdy pipe projecting from the bottom of the exposed bollard. Removable bollards should appear permanent. Electrically controlled mechanisms retract the bollard into a void below the surrounding finish surface. This allows emergency vehicle access to closed streets.



## STREET VENDOR STANDS

Street vendor stands, such as flower, magazine, and food vendor stands, rely on regular pedestrian traffic to sustain their business. To maximize efficiency, the stands operate during daytime work hours and cater to those commuting to/from employment areas. In areas with a vibrant evening environment, stands may have evening hours to benefit from the extended period of exposure to pedestrian traffic.

### Location

Generally, street vendor stands should either be located outside the street right-of-way or in the sidewalk, furniture, or frontage zones.



*Street vendor stand  
(Credit: Sky Yim)*

### Design

The design of the street vendor stands should have details and features coordinated with other street elements. These details should be of a similar architectural character. The stands should allow a minimum of 6 feet of clear pedestrian passage between the edge of the display area and other elements.

## KIOSKS

Kiosks in public areas provide valuable information, such as maps, bulletin boards, and community announcements. Kiosks can often be combined with gateway signs and are an attractive and useful street feature. In Broward County, the B-Cycle automated bicycle rental system has kiosk locations within the streetscape in several areas. More information is available on the B-Cycle website ( <http://broward.bcycle.com/> ).

### Location

Kiosks should not block scenic views. Kiosks may be located in any of the following areas:

- The sidewalk, in furniture or frontage zones (kiosks should not block the pedestrian zone)
- Curb extensions
- Where parking is not allowed
- Close to, but not within transit stops



*Informational kiosk  
(Credit: Paul Zykofsky)*



*B-Cycle Station located outside of the pedestrian zone of the sidewalk  
(Credit: Kimley-Horn and Associates, Inc.)*

### Design

Kiosks should be designed to the following guidelines:

- Kiosks should include bulletin boards or an enclosed case for display of information.
- As a gateway element, the kiosk should include the neighborhood, commercial district, street, or park name; a map; or other information.
- Kiosks should have details and features coordinated with other street elements and should have a similar architectural character.

### NEWS RACKS

#### Location

News rack placement is subject to municipal guidelines. In addition, the following guidelines should be considered:



*News rack  
(Credit: Ryan Snyder)*



- News racks located within the furniture or frontage zones should not reduce the minimum width of the sidewalk pedestrian zone with news rack doors open.
- News racks should be placed no closer than 2 feet from adjacent street signs and 4 feet from bike racks.

### Design

News racks should visually blend with their surroundings and complement the architectural character. Multiple news racks should be consolidated into a standard decorative stand.

### PARKING METERS

Parking meters can be either traditional single-space meters or consolidated multi-space meters (parking stations).

### Location

Parking meters should be placed in the sidewalk furniture zone. Single-space meters should be placed at the front end of the individual stalls.

Multi-space meters are preferred over single-space meters. Multi-space meters should be placed every 8 to 10 parking spaces and spaced approximately 150 to 200 feet apart. Signs should clearly direct patrons to the meter. The signs should be spaced at approximately 100 feet on-center.

### Design

Municipalities should encourage the conversion of single-space meters to multi-space units to reduce visual clutter from the urban landscape. The multi-space units should be selected to minimize their impact on the pedestrian zone.

### SIGNS

Streetscape signs provide information specific to direction, destination, or location. The sign plans should be developed individually for each neighborhood or district. Streetscape signs are most appropriate for downtown, commercial, or tourist-oriented locations or around large institutions. Streetscape signs include parking, directional, and wayfinding signs.



Street signs (Credit: Sky Yim)



### Location

Streetscape signs should be kept to a minimum and placed strategically. They should align with the existing street furnishings and be placed in the sidewalk furniture zone.

### Design

The sign design should be attractively clean and simple and complement the architectural character of other street furnishings.

### REFUSE RECEPTACLES

Refuse receptacles should accept both trash and recyclables. Where there is a demand, different receptacles should be provided for different recyclable materials.



*Refuse receptacle  
(Credit: Kimley-Horn and Associates, Inc.)*

### Location

Refuse receptacles should be located

- Near high activity generators such as major civic and commercial destinations
- At transit stops
- Near street corners but outside of the sidewalk pedestrian zone

There should be a maximum of one refuse receptacle every 200 feet along commercial streets and a maximum of four refuse receptacles at an intersection (one per corner).



## PUBLIC ART

On a large scale, public art can unify a district with a theme or identify a neighborhood gateway. At a pedestrian scale, public art adds visual interest to the street experience.



*Public art  
(Credit: Sky Yim)*

### Location

Public art can be situated in a variety of areas and locations, including streets, public spaces with concentrations of pedestrians, or areas of little pedestrian traffic, to create a unique space for discovery.

### Design

Public art should be considered during the planning and design phase of development to more closely integrate art with other streetscape elements, taking into account the following:

- Public art is a pedestrian amenity and should be presented in an area suited for pedestrian viewing. The piece should be placed as a focal element in a park or plaza, or situated along a pedestrian path and discovered by the traveler.
- Public art can be incorporated into standard street elements (light standards, benches, trash receptacles, utility boxes).
- Public art can provide information (maps, signs) or educational information (history, culture). All installations do not need to have an educational mission; art can be playful.
- Public art should be accessible to persons with disabilities and placement must not compromise the sidewalk pedestrian zone.



## SIDEWALK DINING

Outdoor café and restaurant seating adjacent to the sidewalk activates the street environment and encourages economic development.



*Outdoor café seating: Lauderdale-By-The-Sea  
(Credit: Kimley-Horn and Associates, Inc.)*

### Location

Tables and chairs are to be placed on the sidewalk directly at the front of the restaurant and allowed in the frontage zone or furniture zone of the sidewalk where sufficient width is available.

### Design

Placement of tables and chairs must include diverters (barriers) at the end of the dining area to guide pedestrians away from the accepted area of sidewalk. Since the public purpose of allowing restaurants to have dining on the sidewalk is to stimulate activity on the street, municipalities should prohibit restaurants from fully enclosing the dining area.



## OTHER STREETScape FEATURES

Other features that enhance the pedestrian experience include clocks, towers, and fountains, which strengthen the sense of place and invite pedestrians to come enjoy.



*Other example streetscape fixtures (Credit: Ryan Snyder)*

## UTILITIES

The location of underground and aboveground utilities must be considered when planning new landscaped areas in the right-of-way. Each jurisdiction should establish guidelines to organize and standardize utility location and to minimize conflicts between landscaping and utilities based on input from all affected departments and agencies.

The majority of underground utilities, including sanitary sewers and storm drains, and water, gas, and electrical mains, are typically located under the roadway. Sanitary sewers are often in the center of the street directly under the potential location of a landscaped median. They are usually relatively deep. In general, if they have at least 4 or 5 feet of cover, they should not be affected by the introduction of a landscaped median. The other utilities within the roadway are typically located closer to the curbs.

Telecommunications, street lighting conduit, traffic signal conduit, and fiber optic conduit are often located under the sidewalk. Lateral lines extend from the utility mains in the public rights-of-way to serve adjacent properties.

Benefits of well-organized utility design/placement include:

- Reduced clutter in the streetscape.
- Increased opportunity for planting areas and for soil volume to support tree growth and stormwater infiltration.



- Reduced maintenance conflicts.
- Improved pedestrian safety and visual quality.

## GUIDELINES

### Location

- Utilities should be placed to minimize disruption to pedestrian travel and to avoid ideal locations for directing streetwater, planting trees and other vegetation, and siting street furniture, while maintaining necessary access to the utilities for maintenance and emergencies.
- Utilities within 10 feet of where a landscaped median may be located should have at least 5 feet of cover.
- Utility main lines that run laterally under the sidewalk should be located in a predetermined zone to minimize conflicts with tree roots and planting areas. The ideal location to minimize conflicts with trees would be under the pedestrian or frontage zones, although the more practical location is often under the furniture zone. Stacking dry utilities (telephone, CATV, electric, etc.) in the pedestrian or frontage zones will further reduce conflicts with the landscaped area.

### Roadway/Parking Lane

- Large utility vaults and conduits running the length of a city block may be located in the roadway or parking lane where access requirements allow. Vaults in the parking lane may be located in short-term parking zones or in front of driveways to facilitate access. Each jurisdiction typically has specific design standards for vaults and utilities based on expected use and vehicle type. They can also be placed in midblock curb extensions.

### Furniture Zone

- Small utility vaults, such as residential water vaults, residential water meters, gas valves, gas vaults, or street lighting access, should be located in the sidewalk furniture zone at the back of the curb wherever possible to minimize conflicts with existing or potential tree locations and landscaped areas. Vaults should be aligned or clustered wherever possible.
- Generally, utility boxes are sited in the direction of the pipe. Utility boxes that are parallel with the curb should be located in the sidewalk furniture zone when possible. Vaults perpendicular to the curb should be located between existing or potential street trees or sidewalk landscape locations (for example, in walkways through the sidewalk furniture zone to parked cars.)



- Utility laterals should not run directly under landscaped areas in the furniture zone, but instead under driveways and walkways wherever possible.

#### Sidewalk Pedestrian Zone

- Flush utility vaults and conduits running the length of the city block may be located in the pedestrian zone. Vaults in the pedestrian zone should have slip-resistant covers.
- Large flush utility vaults should be placed at least 3 feet from the building and 4 feet from the curb where sidewalk widths allow.
- Surface-mounted utilities should not be located in the pedestrian zone.

#### Sidewalk Frontage Zone

- Utility vaults and valves may be placed in the frontage zone. Placement of utility structures in this zone is preferred only when incorporating utility vaults into the furniture zone is not feasible.
- Utility vaults in the frontage zone should not be located directly in front of building entrances.

#### Curb Extensions

- Utility vaults and valves should be minimized in curb extensions where plantings or street furnishings are planned.
- Surface-mounted utilities may be located in curb extensions outside of crossings and curb ramp areas to create greater pedestrian through width.
- Utility mains located in the parking lane and laterals accessing properties may pass under curb extensions. With curb extensions or sidewalk widenings, utilities such as water mains, meters, and sewer vents may remain in place as they can be cost prohibitive to move.

#### Driveways

- Utility boxes may be located in driveways if the sponsor provides a vehicle-rated box; however, this is not a preferred solution due to access difficulties.

#### Pedestrian Crossings and Curb Ramps

- New utility structures should not be placed within street crossing and curb ramp areas.



- Existing vaults located in the center accessible portion of a ramp should be moved or modified to meet accessibility requirements, as feasible, as part of utility upgrades.
- Catch basins and surface flow lines associated with storm drainage systems should be located away from the crosswalk or between curb ramps. Catch basins should be located upstream of curb ramps to prevent ponding at the bottom of the ramp.

### Consolidation

Utilities should be consolidated for efficiencies and to minimize disruption to the streetscape:

- Dry utility lines and conduits (telephone, CATV, electric, gas, etc.) should be initially aligned, rearranged, or vertically stacked to minimize utility zones.
- Wherever possible, utility conduits, valves, and vaults (e.g., electrical, street lighting, and traffic signals) should be consolidated if multiple lines exist within a single street or sidewalk section.
- Dry utilities (gas, telephone, CATV, primary and secondary electric, streetlights) may use shared vaults wherever possible. San Francisco has proposed shared vaults with predetermined color coded conduits per predetermined city standards.
- Street lighting, traffic signal, and light rail or streetcar catenary poles should share poles wherever possible. When retrofitting existing streets or creating new streets, pursue opportunities to combine these poles.

### Other Design Guidelines

- Street design and new development should consider the overall pattern of plantings, lighting, and furnishings when placing new utilities in the street, and locate utility lines so as to minimize disruption to the prevailing streetscape rhythms.
- Utilities should be located underground wherever possible, as opposed to overhead or surface-mounted. Overhead utilities should be located in alleys where possible.
- New utilities should use durable pipe materials that are resistant to damage by tree roots and have minimal joints.
- Trenchless technologies, such as moling and tunneling, should be used wherever possible to avoid excavation and disruption of streetscape elements.



*Artfully painted utility box  
(Credit: Kimley-Horn and Associates, Inc.)*



- New infrastructure projects should use resource-efficient utility materials. Re-used or recyclable materials should be incorporated wherever possible.
- Utility boxes may be painted as part of a public art program.
- Tree removal should be avoided and minimized during the routing of large-scale utility undergrounding projects.
- Any utility-related roadway or sidewalk work should replace paving material in kind (e.g., brick for brick) where removed during maintenance, or replace with new upgraded paving materials.

#### New Development and Major Redevelopment

- Alleys for vehicle, utility, and service access should be incorporated to enable a more consistent streetscape and minimize above-ground utilities.
- New utilities should be located to minimize disruption to streetscape elements per guidelines in this section.

#### Abandonment

- Currently abandoned dry conduits should be reused or consolidated if duplicate lines are discovered during street improvement projects. Utilities should be contacted for rerouting or consolidation. Where it is not possible to reuse abandoned mains, conduits, manholes, laterals, valves, etc., they should be removed per agency recommendations when possible to minimize future conflicts.
- Abandoned water and sewer lines may be retrofitted as dry utility conduits where available or if possible to minimize the need for future conduit installations.

#### Process

- Utility installation and repair should be coordinated with planned street reconstruction or major streetscape improvements.
- New development should submit utility plans with initial development proposals so that utilities may be sited to minimize interference with potential locations for streetscape elements.
- Utility work also offers opportunities to make other changes to the street after the work is completed and should be coordinated with planned improvements to avoid duplication of efforts or making new cuts in new pavement. Examples of improvements to streets that can be done at low cost after utility work include restriping for bike lanes if utility work requires total street repaving, as well as building sidewalks in conjunction with utility work occurring outside the traveled way.



## LIGHTING

Lighting provides essential nighttime illumination to support pedestrian activity and safety as well as vehicle safety. Well-designed street lighting enhances the public realm while providing safety and security on roadways, bike paths, and lanes as well as pedestrian paths including sidewalks, paths, alleys, and stairways.

Historically significant street light poles and fixtures should be maintained and upgraded where appropriate.

Pedestrian lighting should be coordinated with building and property owners to provide lighting attached to buildings for sidewalks, alleys, pedestrian paths, and stairways where separate lighting poles are not feasible or appropriate.



*Street lamps (Credit: Sky Yim)*



## Guidelines

### **Location and Spacing**

(1) Street and pedestrian lighting should be installed in the sidewalk furniture zone; (2) light fixtures should not be located next to tree canopies that may block the light; (3) where pedestrian lighting is not provided on the street light pole, special pedestrian lamps should be located between street light poles.

### **Light Color**

All light sources should provide a warm white (yellow, not blue) color light. Low pressure sodium lights are recommended for areas near sea turtle nesting beaches.

### **Light Poles and Fixtures**

Design should relate to and be coordinated with the design of other streetscape elements and recognize the history and distinction of the neighborhoods where the light poles are located.

### **Dark-Sky Sea Turtle Compliant Lighting**

As appropriate, dark sky-compliant lighting should be selected to minimize light pollution cast into the sky while maximizing light cast onto the ground. Lighting near sea turtle nesting beaches, which includes all beaches in Broward County, cannot trespass onto the beach. The Florida Fish and Wildlife Conservation Commission provides guidance on sea turtle friendly lighting at:

<http://www.myfwc.com/wildlifehabitats/managed/sea-turtles/> .



*Sea Turtle Nesting Sign  
(Credit: Kimley-Horn and Associates, Inc.)*



**Energy Efficiency**

Solar light fixtures should be utilized where possible for new installations or for retrofit projects. Where solar light fixtures are not appropriate or possible, LED or a future more energy-efficient technology should be used.

**Pedestrian Lighting**

Retrofits of existing street lights and new installations should provide lighting on pedestrian paths. Pedestrian lighting should be added to existing street light poles where feasible unless spacing between street light poles does not support adequate pedestrian lighting, in which case pedestrian lighting may need to be provided between existing street light poles.

**Light Levels and Uniformity**

All optic systems should be cut off with no light trespass into the windows of residential units. Local jurisdictions should develop a set of standards for pedestrian lighting levels based on Table 12.3 to achieve adequate lighting.

**Table 12.3 Pedestrian Light Levels**

STREETSCAPE TYPE	LIGHT LEVEL
Commercial	1 fc
Mixed-Use	0.5 fc
Residential	0.4 fc
Industrial	0.3 fc
Alleys and Paseos	0.3 fc
Special	Varies

Note: Light levels are measured in foot candles (fc).  
 Suggested light levels are consistent with  
 ANSI/IES RP-8-00 American National  
 Standard Practice for Roadway Lighting

**ADDITIONAL RESOURCES**

Lancaster, B. *Rainwater Harvesting for Drylands and Beyond*,  
<http://www.harvestingrainwater.com/>

Landscape Architecture Foundation’s Landscape Performance Series,  
[www.lafoundation.org/lps](http://www.lafoundation.org/lps)

NatureScape Broward,  
<http://www.broward.org/NaturalResources/NatureScape/Pages/Default.aspx>



This page left blank intentionally.



## 13. RE-PLACING STREETS: PUTTING THE PLACE BACK IN STREETS

INTRODUCTION.....	1
PUBLIC SPACE AND THE NEED TO RE-PLACE STREETS.....	1
PLACEMAKING FOR STREETS.....	4
Design Techniques and Goals for Replaced Streets.....	5
STRATEGIES TO RE-PLACE STREETS.....	10
The Street’s Place in the Community.....	10
Placemaking Participants.....	11
The Placemaking Process.....	12



*(Credit: Kimley-Horn and Associates, Inc.)*



## INTRODUCTION

Most American cities have come to view streets primarily as conduits for moving vehicles from one place to another (from A to B is the common expression). While moving vehicles is one of their purposes, streets are spaces, even destinations in and of themselves. Conceiving of a street as a public space and establishing design guidelines that serve multiple social functions involves several fundamental steps. Behind them all is a redefinition of whom streets ought to serve. By approaching streets as public spaces, local jurisdictions redirect their attention from creating traffic conduits to designing a place for the people who use the street.

### PEOPLE PUT THE PLACE BACK IN STREETS

This chapter describes the need for local jurisdictions to “re-place” their streets—make streets places and refocus their purpose on the people who use them—and how local jurisdictions can do so. The chapter outlines the key features and functions of re-placed streets and the design elements used to achieve re-placed streets. The chapter concludes by describing the process local jurisdictions can follow to ensure streets come to reflect a community’s strengths, needs, and aspirations.



*Las Olas Street Fair, Fort Lauderdale  
(Credit: Urban Health Partnerships, Inc.)*

## PUBLIC SPACE AND THE NEED TO RE-PLACE STREETS

Public spaces are the stages for our public lives. They are the places shared by all members of a community, of any size. Quality public spaces are places where things happen and where people want to be, vital places that highlight local assets, spur rejuvenation, and serve common needs.



Streets comprise a large portion of publicly owned land in Broward County. Streets are a huge part of any community's public space network, and historically served as meeting places, playgrounds for children, marketplaces, and more. As populations spread out from city centers, streets lost many of these functions and were instead designed and planned for one use: mobility. At best, streets conceived as complete streets address the mobility needs of all street users (pedestrians, cyclists, drivers, and transit riders). During the last century, however, automobiles have been prioritized over people as users of our streets.



*Pavement to Parks program: San Francisco, CA  
(Credit: Sky Yim)*

As part of the public realm, successful streets have a variety of functions beyond allowing automobiles to travel rapidly. For this reason, placemaking, or celebrating and maximizing Broward's many diverse open spaces, must be at the core of the planning and design of our streets to meet the following challenges:

- **Population growth and urbanization.** People moving back into cities will need to be accommodated in limited space, putting greater demands on existing streets. If streets continue to largely function to move people traveling in motor vehicles, they will not be able to accommodate this growth. Streets will need to enable people to do more while traveling less and to travel more efficiently.
- **The need to maximize social and economic exchange.** Streets will need to serve the highest and best use for the land they are on, and mobility is only one among many possible uses. Streets need to be designed to maximize social value, which also spurs healthy economic exchange. In this way, streets become arteries distributing prosperity. Streets that invite social interaction are more likely to ensure healthy growth.

*"We have inadequate sidewalks, poor street lighting, fast moving traffic on third avenue and no bike lanes. The majority of the properties are dilapidated and it feels dangerous...I ... don't feel comfortable walking my dog at night."*

*- (Broward Complete Streets survey respondent)*



- **The need to reduce energy consumption and induce sustainable growth.** Streets that are places promote locality. They enable people to travel comfortably by non-motorized modes, which in turn shortens travel distance demand. With growing concerns regarding fuel resources and climate change, this shift will be critical. Because re-placed streets spur locality-serving commerce and social venues, they also set the stage for and enable healthy and environmentally sustainable practices/behaviors in the surrounding built environment.
- **A desire to create public space.** Beyond being the frames for other development, streets can be public spaces themselves. Access to public space is critical to safe, healthy, and successful communities. When streets are designed as great spaces for people, they reinforce a sense of belonging and build on the strengths of the communities they host.



*Lauderdale-by-the-Sea  
(Credit: Alena Alberani)*



*Downtown Hollywood  
(Credit: City of Hollywood)*



## PLACEMAKING FOR STREETS

In order to be places, streets must:

- Augment and complement surrounding destinations, including other public spaces such as parks and plazas
- Reflect a community's identity
- Invite physical activity through allowing and encouraging active transportation and recreation
- Support social connectivity
- Promote social and economic equity
- Be as pleasant and accessible for staying as for going
- Prioritize the slowest users over the fastest
- Balance mobility and public space functions



*Good public space invites social interaction  
(Credit: Dan Burden)*

So that people can

- Walk and stroll in comfort
- Sit down in nice, comfortable places, sheltered from the elements
- Meet and talk—by chance and by design
- Look at attractive things along the way
- See places that are interesting
- Feel safe in a public environment
- Enjoy other people around them
- And get where they need to go!



*Hollywood Broadwalk  
(Credit: Kimley-Horn and Associates, Inc.)*

Re-placed streets must be slow streets that are inviting and filled with human activity. This is the most important distinction between streets designed for maximal car throughput and re-placed streets; it requires the necessary scalar adjustment from car to people-focused street



planning. Streets designed for fast and far movement favor people moving by motor vehicles, not people moving under their own power. Human energy limits people to slow and local movement.

Because people, not motors, are essential to long-term growth in places of all kinds, human-scaled streets are an inducement to healthy lifestyles and economic resilience.

## DESIGN TECHNIQUES AND GOALS FOR REPLACED STREETS

A re-placed street balances the moving and staying needs of its users and has multiple, people-serving purposes. The design techniques and goals detailed below describe how to create re-placed streets.



*Street performer (Credit: Ryan Snyder)*

### Support and Encourage Activities and Destinations

- Widen sidewalks to accommodate multiple activities
- Open streets to multiple activities
- Encourage/provide active ground floor uses in adjacent buildings
- Cluster activities and amenities
- Allow street vendors and performers

### Design Street Elements and Adjacent Buildings for the Human Scale

- Use amenities that are pedestrian-scaled including:
  - Signs
  - Lighting
  - Seating
- Encourage building design (e.g., through zoning regulations and design guidelines) that is scaled to the human body, such as:
  - Frequent building entrances
  - Building transparency at street level
  - Interesting facades



*Public art in traffic circle median: Lauderdale-by-the-Sea (Credit: Kimley-Horn and Associates, Inc.)*



*Walk streets used as play space:  
Manhattan Beach, CA  
(Credit: Dan Burden)*



*Transparent storefronts blur the distinction between  
indoor and outdoor space, and public and private space:  
Avalon, CA  
(Credit: Ryan Snyder)*

### Provide a Feeling of Safety and Security on Streets

- Keep streets well-maintained and both the street and surrounding buildings well-lit
- Select streets adjacent to round-the-clock-active buildings and public spaces
- Invite diverse people and uses throughout the day
- Slow traffic to a comfortable speed to mix with other travel modes through
  - Low speed design elements
  - Traffic calming techniques
  - Shared space
- Maintain a buffer between pedestrians and vehicles when there is fast moving traffic using
  - Planters
  - Bollards
  - Parked cars
  - Kiosks, newsstands, public toilets, lampposts



*Wide comfortable sidewalks tend to lead to safe  
destinations  
(Credit: Kimley-Horn and Associates, Inc.)*



### Connect Both Sides of the Street

- Shorten crossing distance through
  - Narrow travel lanes
  - Curb extensions and pedestrian islands
  - Building activities connected to the street
- Invite people to cross in more places by
  - Slowing vehicular traffic
  - Establishing mid-block crossings
  - Making shared streets



*Landscaped buffer between pedestrians and motor vehicles  
(Credit: Kimley-Horn and Associates, Inc.)*



*Landscaped curb islands, decorative pavers, and no centerline stripe help give this festival street a sense of place while calming traffic  
(Credit: Kimley-Horn and Associates, Inc.)*



Show a Sense of Ownership

- Provide for maintenance and cleanliness
- Engage community/local residents in maintenance
- Accommodate diverse programming appropriate for the season and time-of-day, such as:
  - Greenmarkets/farmers' markets
  - Street fairs and festivals
  - Ciclovía-style events
  - Volunteer events
  - "Open-street" events
  - Celebrations of Broward's diverse cultures



*Street fair*  
(Credit: Kimley-Horn and Associates, Inc.)



*Ciclovía, Bogotá, Colombia*  
(Credit: Stewart Robertson)



### Reflect Community Identity

Unique community identity draws from the natural setting and local history, as well as the cultural backgrounds of community residents and their architectural tastes.

- Showcase local assets including:
  - Monuments and building architecture
  - Views
  - Trees and other plants
  - Other natural features (water, topography)
  - Parks and plazas
  - History
  - People
  - Intersections transformed into meeting places
- Invite a diversity of users
- Reference or preserve continuity of local aesthetics

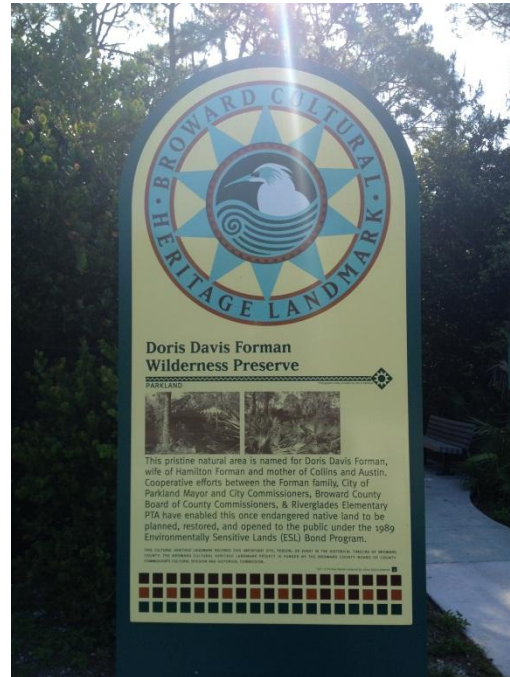

*Broward Cultural Heritage Monument Sign  
(Credit: Kimley-Horn and Associates, Inc.)*



*Sidewalk through mature tree canopy with well-placed street furniture  
(Credit: Kimley-Horn and Associates, Inc.)*



Move Community towards  
Local Sustainability

- Utilize on-site and local resources where possible
- Use surface area for energy capture
- Use effective stormwater management techniques including
  - Bioswales
  - Rain gardens
- Use open space for growing food (community gardens)



*Rain garden as buffer between pedestrians and motor vehicles  
(Credit: Stewart Robertson)*

## STRATEGIES TO RE-PLACE STREETS

Re-placing streets requires building streets around a community's vision that the street can support. Re-placing a street is an opportunity to open a process wherein communities remind themselves of their strengths and establish a shared and sustainable vision for their future. Before a city can proceed with street redesigns that create a sense of place, it must address the following issues.

### THE STREET'S PLACE IN THE COMMUNITY

Streets, the built environments they connect, and the people who use them compose a community. Thus, it is important to situate the street in its spatial context and identify the places it connects. It is equally important to identify whose needs the street should serve. This may include tenants and property owners, students, employees, local civic associations, and religious institutions.



*Pavement emblems in a sidewalk  
(Credit: Kimley-Horn and Associates, Inc.)*



## PLACEMAKING PARTICIPANTS

At the heart of placemaking is the idea that each community has the means and the potential to create its own public spaces. Before a city can proceed with street redesigns that attend to the multiple functions of public space through placemaking, it is important to identify who needs to be involved to frame the meaning of place and the vision for that community and to provide the needed information, resources, and expertise to realize that vision.



*B-Cycle Station well-situated within the public space  
(Credit: Kimley-Horn and Associates, Inc.)*

### The Community

Since place is an outgrowth of community character, re-placing should invite the collective influence of a community's diverse residents and users. In re-placing a street, it is important to establish who has a stake in the neighborhood, and give all of these groups and individuals the opportunity to come to the table and contribute. As noted above, the groups may include tenants and property owners, students, employees, and community-based groups like civic associations and religious institutions. The appropriate public space functions of streets should be defined by these multiple users, often referred to as "stakeholders."

### Multiple Agencies

Within a local jurisdiction, multiple agencies should be included and engaged in re-placing a street. A department of transportation alone cannot create a street that is a place. Any agency with responsibility for the regulation, construction, operations, or maintenance on or adjacent to the street should be included in the project early in the process. In addition to the department of transportation, this might include public works, the parks department, utilities, and the planning or zoning department. All agencies must bring their needs and constraints to the table, but more importantly they must understand the community's vision and goals for making the street a place. They can then begin considering what they need to do to carry out the will of their community.



### A Multi-Disciplinary Team

A successful street is a complex place, and the information, insight, and skills required to make it a successful place are many and diverse. It is beyond the experience of any one profession to deal with any of these issues. The role of professionals is as a resource for the community and to implement the community's vision.

### THE PLACEMAKING PROCESS

The placemaking process should be fun, engaging, and empowering for a community; build on existing human resources; and result in increased community social capital. Chapter 3, "Community Engagement," provides the details of the type of public process that should be used to ensure community involvement and place-based planning. Below are processes especially important to placemaking.



*Active bus stop with bicycle commuters  
(Credit: Bikes Belong Foundation)*

### Establish a Community Vision of What the Street Is and Should Be

Infrastructure forecasts what later springs from the built environment: a street's public space functions can be an inducement to a community's growth aspirations and not just an accommodation of existing behavior. Determining the optimal uses and design for a given community's streets involves identifying the strengths and needs of its users. Because it involves a scalar adjustment, this is the most important distinction between a street designed to be a place, with many functions, and a street designed for the single function of maximizing car throughput. A process that allows the community of street users to define these strengths and needs and establish a vision for the street is critical.

### Involve the Public in Assessing the Strength, Needs and Opportunities on the Street

The project must start by going directly to the residents and neighborhoods to evaluate and establish a vision for the street. A critical part of this will be an assessment of whether places on the street are performing well or need improvement. The assessment should include a grassroots identification of needs for enhancement of underperforming places and opportunities for the creation of new places so that the street can achieve the critical mass of places needed to function as a destination itself. In addition to places on the street, the community should be engaged in an on-site diagnosis of the street itself to determine how it is performing. A variety of tools and audits exist for such assessments, but at heart they should



engage the community in assessing the characteristics, described in the previous section, that make a street a place.

### Establish a Community Vision Based on This Assessment

The community process should result in a community-generated vision for what the street can and should be, including the things people should be able to do on the street and the way that people feel doing them. The vision should be generated by people who use the street. Such a vision is generally quite realistic and practical yet contains innovative ideas because the vision is grounded in reality but isn't generated by just one individual or group.

The vision should contain:

- A mission statement of goals.
- A definition of how the street will be used and by whom.
- A statement of the desired character of the street.
- Suggestions and a conceptual idea of how the street could be designed.
- Models or examples of places that community members would like the street to be like or elements they would like to use.



*Sun Trolley on Fort Lauderdale Beach  
(Credit: Luisa Fernanda Arbeláez)*

### Develop a Plan Based on This Vision

There will need to be a plan for realizing the vision. It might not include every step to realize the vision, but it should begin to lay out next steps and identify things that all partners, including the agencies, the professionals, and the community, can do to move re-placing the street forward.

### Prioritize Interventions Based on This Vision

The vision will contain many ideas. However, some will be more important or more critical than others. Additionally, some will be easier to implement than others. The community will need to prioritize individual ideas and strategies in order to begin to take action in re-placing the street.



### Select and Implement Short-Term/Temporary/Pilot Projects

First on the action plan should be short-term or pilot projects. Such projects can be a way of testing ideas for long term change at a lower cost while providing flexibility for adaptation and change. Such projects also give people confidence that change is occurring and that the ideas they have contributed matter. This is important because re-placing streets takes time, and smaller, simpler changes can provide small steps that keep people engaged in the process of placemaking. Short-term and pilot projects allow people to see how the street is working with changes introduced gradually over time, enabling people's perceptions of how the street functions.

New York, San Francisco, Portland, and other cities have quickly transformed streets into vibrant public space with such techniques as

- Establishing non-vehicular space with planter boxes, temporary curbs, and wooden platforms
- Painting the pavement under the newly repurposed space
- Bringing in portable tables, chairs, and awnings
- Incorporating decorative street painting projects



*Examples of low-cost, short-term devices that transform streets:  
San Francisco, CA (Credit: Sky Yim)*

### Establish a Maintenance and Management Plan

Maintenance and management is critical because streets are not static—they change daily, weekly, and seasonally—and streets must adapt and be flexible to this change. Thus, public space management may be required. Management becomes especially critical where events, such as farmers' markets, fairs, festivals, and Ciclovías, are programmed. Great streets are also well loved and well used. To sustain a quality street environment, the community must commit to leverage local resources such as Associations and Improvement Districts for a long-term investment in the re-placed street.



*Examples of low-cost, short-term devices that transform streets:  
Broadway, New York, New York (Credit: Paul Zykojsky)*



**This page left blank intentionally.**



## 14. DESIGNING LAND USE ALONG COMPLETE STREETS

INTRODUCTION.....	1
ESSENTIAL PRINCIPLES FOR BALANCED STREET ENVIRONMENTS .....	1
STREETScape ENVIRONMENT TYPES .....	3
Neighborhoods.....	3
Neighborhood Centers .....	4
Corridors .....	6
Urban Centers .....	8
Special Use Districts .....	10
Urban Design.....	12
Thoughtful Site Design .....	14
Buildings’ Relationship to Sidewalk .....	15
Appropriate Building Forms.....	16
POTENTIAL IMPLEMENTATION STRATEGIES .....	18
HEALTH AND LAND USE.....	19
BENCHMARKS .....	21



*(Credit: Kimley-Horn and Associates, Inc.)*



## INTRODUCTION

Streets provide access to buildings and land uses of every kind. As discussed in Chapter 13, “Re-Placing Streets,” placemaking is the practice of first designing streets and other public spaces as an interconnected network of human-scale “public living rooms” in which the safety and comfort of pedestrians and bicyclists is not subordinated to the requirements of access by automobile, and then coordinating the character and design of the adjoining properties to create a specific type of living environment, or place.



*Complementary land use and street design  
(Credit: Dan Burden)*

All successful and sustainable communities include a range of distinct and different types of places, or environments, from quiet, shady residential streets to busy neighborhood centers, from noisier mixed-use “bright lights” downtowns to larger, single-purpose industrial and employment centers. While the type of land use is one important characteristic of private property design in these places, site and building design are critically important in ensuring that coherent, safe, functional, and valuable places result. For these reasons and more, the Broward Complete Streets Initiative partnered with the Smart Growth Partnership team of walkable, livable, communities.

This chapter provides a discussion of the ways in which the planning and design of properties contribute to coherent placemaking. The discussion includes placemaking principles that are applicable to places of all types and to distinct types of places, design techniques for applying the basic placemaking principles, and implementation strategies for embedding these principles and techniques in local policies and regulations.

***“I’d increase my (physical activity) by walking if more businesses and restaurants were nearby”***

*- (Broward Complete Streets West Park public workshop participant)*

## ESSENTIAL PRINCIPLES FOR BALANCED STREET ENVIRONMENTS

The following design principles inform the recommendations made in this chapter and should be incorporated into all street environment design:



- Urban patterns in livable, sustainable places of enduring value are generally based on compactness, connectivity, completeness, and continuity. This describes the opposite of sprawling, disconnected, or single-use development.
- Streets are the outdoor rooms of their neighborhoods, and should be designed for and scaled for people. They are also the structural framework that organizes those places, making them legible and navigable.
- The purpose of streets is to let people move about, and every street should provide safety, convenience, and comfort for pedestrians and bicyclists. In communities with subpopulations of elders or those with disabilities, access by foot or assistive device to distinct uses such food retail or medical centers are essential to increasing quality of life.
- Streets, parks, plazas, squares, and other public places make up the public space network in which all members of the community may encounter one another in the course of their daily lives, regardless of their age, income, or other individual status.
- Street networks designed with pedestrians in mind, as described in Chapter 4, “Street Networks and Classifications,” naturally form small to medium-sized blocks that allow pedestrians to comfortably walk to a range of amenities as a pleasant and practical alternative to driving. In existing environments where such a network exists it should be preserved, and in areas where large parcels are being redeveloped, such a network should be inserted.
- The distribution of land uses should be designed to allow everyday destinations (e.g., schools, parks, and retail shops) to be located within a comfortable walking distance of most residences.
- All buildings should contribute to the character of the streetscape, face the street with attractive entrances that welcome pedestrians, and have windows that overlook the street to create a sense of security.
- On-street parking reinforces a pattern in which visitors enter buildings from the street, and can provide an important buffer between pedestrians and moving traffic.
- The setback between buildings and the sidewalk should be designed to enhance the pedestrian experience, whether setbacks are attractive landscaped yards that provide privacy for building occupants or shopfronts at the sidewalk that display merchandise to passing pedestrians. In no cases should cars, parked or moving, be placed between the sidewalk and the buildings.



*Good building setback (Credit: Ryan Snyder)*



- Off-street parking and service access and their driveways should be designed to disrupt the pedestrian experience as little as possible. Whenever possible, access should be from an alley or shared driveway off a side street and parking and garages should be located behind or beside buildings, not between the sidewalk and the building. When a driveway to the front of the lot cannot be avoided, it should be as narrow as possible.
- Off-street parking, especially surface parking, is a non-productive use, and the amount required should be reduced to the extent possible by utilizing on-street parking and by sharing off-street parking among adjacent uses. Off-street parking requires about twice the surface area per parked car of on-street parking, due to the driveways required to access the lot and aisles needed for maneuvering within the lot. This non-productive space creates dead zones and increases the distances between destinations, further reducing the attractiveness of walking.
- The mix and intensity of land uses should be designed to support and be supported by efficient transit systems whenever possible.

## **STREETSCAPE ENVIRONMENT TYPES**

Every city, town, neighborhood and district is unique. This uniqueness creates a sense of place. However, there are a few general types of places that repeat from community to community, within which the idealized relationship of street to adjacent land uses follows certain general guidelines. The following descriptions of archetypical environments detail concepts and strategies, not finite design solutions. Designs should be based on the best of the local and regional architectural and landscape heritage. Communities may want to establish their own typologies for local environments and streets.

### **NEIGHBORHOODS**

Neighborhoods are the main component of all cities, the places where almost everyone lives. Many of the concepts below reflect some of Broward's best loved and most valuable neighborhoods:

- Residences of various types are the predominant land use of neighborhoods, with other uses such as neighborhood-serving retail, small businesses, elementary schools, parks, and playgrounds within a pleasant walk.
- Neighborhoods can be composed primarily or even exclusively of single family homes, or can include a range of multifamily housing types that are designed and scaled for their compatibility with houses. The basic design principles listed here are the same for both.
- Neighborhood streets are the living rooms and play rooms of the neighborhood, and should be designed mainly for the safety and enjoyment of pedestrians, particularly children and the elderly, the most vulnerable pedestrians among us.



- The streetscape environment of neighborhoods is the most heavily landscaped type, with sidewalks flanked by street trees and landscaped parkway strips on the public side and landscaped front yards on the private. This creates a distinctive streetscape character different from that in neighborhood centers and other mixed-use environments.
- On-street parking serves visitors and residents, and provides a valuable buffer between pedestrians, children at play, and passing traffic.
- Buildings should front the street with gracious front doors and overlook the street with windows to provide eyes on the street and a sense of security for the street.
- Front yard design should create spaces through which residents and visitors come and go in their daily routines, in which neighbors interact and children play, and where food can be grown.
- The front door of houses and active uses within them should be closer to the street than the garage to emphasize the home over car storage and to bring eyes closer to the street.
- Automobiles should disrupt the pedestrian environment (primarily sidewalks) as little as possible. This can be accomplished by providing access to parking and garages via alleys and driveways from side streets, or when necessary via driveways from the fronts of lots (as few and as narrow as possible) to access garages located behind or beside, not in front of, the residences.



*Streets and buildings working together  
create attractive neighborhoods  
(Credit: Ryan Snyder)*

## NEIGHBORHOOD CENTERS

Neighborhood centers take many forms and occur at all scales, from a country store at a key intersection in a rural neighborhood to a busy little “Main Street” environment in a larger town or city to a high intensity, transit-oriented center at a neighborhood edge along a major urban corridor. Regardless of the scale and character of the neighborhood center, the following set of basic design concepts can define centers that are convenient to pedestrians from adjoining neighborhoods:



- Neighborhood centers, the name notwithstanding, are generally at the edges or corners of neighborhoods, facing a major street or streets that carry traffic volumes capable of supporting the businesses. An ideal arrangement is a “Main Street” that is located at the conjunction of two or more neighborhoods, making the edges of the neighborhoods into the center of the larger community, and providing a range of amenities and resources within easy walking and biking distance of the residents.



*Neighborhood center  
(Credit: Ryan Snyder)*

- Neighborhood centers are ideally mixed-use, providing an array of goods, services, employment, and residential options that can function both as an extension of the adjoining neighborhoods and as a convenient destination for people passing through.
- The buildings of these centers should face the primary street, creating a busy pedestrian environment that causes drivers to slow down and see what the center has to offer.
- The ground floor uses in neighborhood centers are generally commercial, providing convenient goods and services to customers; the upper floors can be residential, office, or a mix of both.
- The streetscape in neighborhood centers is usually quite formal: street trees are normally located in small planters within the sidewalk, surrounded by tree grates or very small landscaped areas, providing space for pedestrians to comfortably stroll, and for people to get in and out of cars parked curbside.
- There are many options for the design of setback areas in neighborhood centers, including forecourts with sidewalk dining, narrow landscape zones that soften the streetscape while allowing views of the shops, and simple shopfronts built right to the sidewalk.
- Neighborhood centers can also include purely residential buildings, as long as the design of the ground floor street interface provides a degree of privacy for the residents, either by setting the building back behind a landscaped yard or raising the ground floor above the sidewalk level, or both.
- Except for the smallest centers, which might just be one corner store, neighborhood centers generally require off-street parking, which should be located behind or alongside the buildings whenever possible, not between the sidewalk and the buildings.



- In larger neighborhood centers that require large off-street parking lots, the size of the lots can be reduced if they are shared by uses whose peak parking demand is in the daytime (offices) and uses whose peak use is at night (e.g., dinner restaurants and residences). Reducing parking saves cost, improves environmental performance, and improves the urban environment for people.
- Plazas can create vibrant urban centers. Their design should focus on proper size and scale, active uses, doors and windows fronting the plaza, trees, landscaping, public art, fountains, etc. Stages, bandstands, play fountains, and other features liven plazas.



*Public pavilion in a plaza overlooking the beach at a street end: Lauderdale-By-The-Sea  
(Credit: Kimley-Horn and Associates, Inc.)*

## CORRIDORS

This section focuses on major street corridors that connect across an urban area. Corridors can have many different characteristics and occur at all scales, from a rural main street stop along a



highway to a main avenue within a town or a high intensity urban corridor in a large city. Many planning and design concepts are common to corridors at all these scales.

Many major street corridors began as rural roads, evolved into automobile thoroughfares lined with a range of commercial uses, and have lately been losing much of their commercial value, as retail and office uses have migrated to larger-format retail centers and business parks. Many such corridors now present a significant opportunity for communities to provide infill housing mixed with modest amounts of commercial uses within walking distance of adjoining neighborhoods.



*Mixed-use building along Wilton Drive brings together housing, shopping, work, and transit for shorter trips and fewer vehicle miles traveled  
 (Credit: Luisa Fernanda Arbeláez)*

The repositioning of these often blighted “commercial strips” as more valuable mixed-use places requires a coordinated redesign of the streets and careful planning of the infill development along the corridor.

The street design principles and practices described in this manual will help create streets that do more than move cars. Using these principles and practices, undifferentiated miles of corridors can be restructured to provide the types of neighborhood centers described above, interspersed with residential or office uses along the street. The core placemaking strategies found in this manual (slowing cars, planning for people, landscaping streets, providing on-street parking, and designing property setbacks to modulate privacy for residences and visibility for businesses) can transform miles of sameness into a sequence of useful places.

Below are of some core design concepts and principles that can help to integrate land uses with such streets to make coherent, human-scale places:

- The entire length of a corridor should be lined with active uses. These can include the neighborhood centers described above at appropriate nodes, multifamily housing of various types, and even single-family housing if appropriately buffered with landscaped setbacks or a multi-way boulevard. Sound walls, berms, and other forms of “pure buffer” are an admission of urban design failure, disconnecting the city rather than connecting it, and should be employed as a last resort.



- Through a community visioning process integrated with transit planning processes and retail capacity studies, the location and size of neighborhood centers (active, mixed-use, and often transit-oriented nodes) should be determined.
- Long corridors should be analyzed to define the existing or emerging character by segment, then potential nodes, centers or destinations with more focused pedestrian activity can be identified.
- A mix of land uses can be provided to encourage people to make trips by means other than cars in those locations, and a network of streets to assure connections between uses should be available.
- Design standards or guidelines for development within the segments that will remain auto-oriented should be created so these segments can be made as pedestrian and bicycle-friendly as possible (e.g., minimizing the number of curb cut locations and widths that interrupt the sidewalk, buffering street-frontage parking so the sidewalk environment is not compromised, providing setbacks for landscaping and transit amenities wherever possible to encourage transit use).
- In close consultation with the residents of adjoining neighborhoods, the vision and standards for the design and massing of buildings in each segment of the corridor should be developed.



*Blank walls and inactive uses on the ground floor make for poor pedestrian environments  
(Credit: Ryan Snyder)*

## URBAN CENTERS

Urban centers are typically the economic and social hearts of cities or towns. They can be village-scale centers in small towns, low to mid-rise downtowns in most cities, or high intensity urban centers with high-rise buildings in larger cities, where unique regional destinations are often located.



*Urban center: Vancouver, BC (Credit: Dan Burden)*

Ideally, the urban center environment is a very compact mix of a wide range of land uses, creating high land values as well as a high potential for transportation congestion. Accordingly, it is vitally important that in addition to a balanced street network for pedestrians, bikes, and cars, such places be provided with high levels of transit service. Important design concepts for urban centers include the following:



*Connect surrounding land use to transit stops with paths and attractive gates  
 (Credit: Kimley-Horn and Associates, Inc.)*

- Urban centers are usually organized around an established network of major boulevards and urban streets that support the businesses and major public institutions. Because networks that are scaled and designed for pedestrians are finite in their traffic carrying capacity, it is critical that transit plays a major role in moving people.
- Urban centers are mixed in use, providing an array of goods, services, employment, and residential options along with important public and cultural institutions.
- Buildings in urban centers should face the primary street (which can often be more than one side of a block), and support an active pedestrian environment.
- Buildings in large urban centers should form a consistent street wall (following a consistent pattern of setback and height); the street wall is typically at the back of a wide sidewalk and appropriate to the character of the street it fronts.
- Along streets with purely residential buildings, the design of the ground floor-street interface should provide a degree of privacy for the residents, with residences normally set back from and raised above the sidewalk.
- Commercial uses generally front the sidewalk with large, transparent shopfronts, but some institutional and office uses commonly connect to the sidewalk environment with lobbies and foyers instead. In such cases, it is important that windows from the offices and other interior spaces overlook the street to support an environment that feels safe.
- For hotels and office buildings that require porte-cochere or drop-off areas for residents or guests, these should ideally be designed to occur at the street edge along the curb zone, and should not impose large curb cuts and circular driveways that interrupt the sidewalk. When such off-street vehicular access must be provided, it should be integrated into a forecourt or entry plaza that is designed first as a public space for people, and incidentally allows vehicular access that does not disrupt the pedestrian



environment. The width of the pedestrian zone should be maintained throughout; the furniture and/or frontage zones can be reduced.

- Parking in urban centers should include
  - On-street parking to buffer pedestrians from faster moving traffic
  - Shared, aggregated parking that is located underground wherever possible
- Above-grade structured parking should be lined with ground floor active uses that front the streets, not exposed or hidden with blank walls. This also applies to upper floors, where stacking exposed parking levels above the street-level commercial uses should be avoided.
- Where surface parking lots are unavoidable, they should be behind a building that fronts the sidewalk and public street, or at a minimum screened with attractive landscape or public art to provide a comfortable street edge for passing pedestrians. Vendor kiosks or “slim stores” can also be used for this purpose.

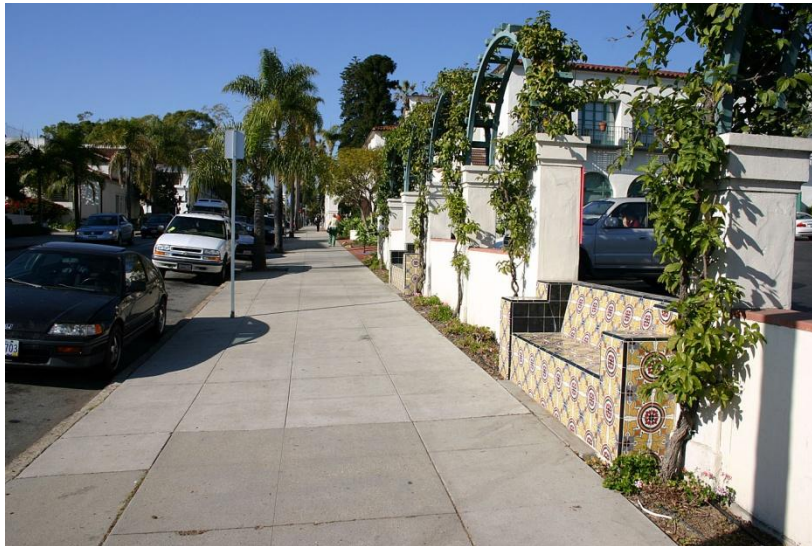

*Well screened surface parking: Santa Barbara, CA  
(Credit: Paul Zykofsky)*

- The key to district parking strategies is creating a supply of available parking that is shared by many uses, whose peak parking demands will be at different times of the day and the week. This, together with a strong transit component and an attractive walking and biking environment, will reduce the required amounts of parking, which in turn will save cost, increase real estate utilization, improve environmental performance, and improve the urban environment for people.

## SPECIAL USE DISTRICTS

Special use districts are areas dominated by a single type of land use. One example of this is industrial districts, where manufacturing, production, and distribution of goods are the primary activities. Other examples are employment centers that primarily provide high concentrations



of commercial offices, medical centers, and large education campuses. Such districts benefit from a location that provides easy access to regional roads and highways, and the sizes of their buildings, the volumes of truck traffic, and the hours of operation make them generally unsuitable for residential uses.

It is important to note that even within special use districts, there are many opportunities to mix in useful amenities and strong reasons to ensure that all the streets are walkable, bikeable, and served by transit. In industrial, office-dominated, educational, or medical campus districts, this enables restaurants, copy centers, and other support businesses to do well while reducing workers' need to drive out of the district for basic services. These local-serving commercial uses can thrive if the environment supports their patronage, and housing can be integrated as well. Some key principles for the design of such districts include the following:

- Districts can foster a critical mass of related businesses that function well in close proximity to each other (like industrial suppliers and manufacturers, or medical offices and a hospital).
- It is important that special use districts be organized around a balanced street network, with development standards to ensure that the urban design does not exclude pedestrians, bicyclists and wheelchair users. Many employees and visitors arrive to their jobs by transit or bicycle, so accommodating pedestrians should be as important as moving goods and vehicles between businesses. Many employees who drive or take transit to work walk or bike to local destinations during their lunch breaks.
- Where other uses (e.g., restaurants, cafes, and small convenience stores) are interspersed within the dominant land use, they should provide a pedestrian-friendly street frontage to encourage employees or visitors to arrive from nearby businesses on foot.
- Major corridors entering special use districts typically carry heavier traffic and trucks, but also need to safely accommodate bicycles and pedestrians.
- The street network should assure that truck freight traffic has clear paths of travel that do not encroach on sidewalks.



*Adjacent outdoor seating livens the street:  
(Credit: Kimley-Horn and Associates, Inc.)*



- Buildings in special use districts should provide a good public face along the streets, with noxious or unattractive uses behind buildings or attractive fences and landscaping.
- For special use districts like medical centers, the building frontage and entrances onto the campus and its individual buildings from the sidewalk should be pedestrian friendly and accommodate the mobility-impaired. Services open to the public, such as cafés and gift shops, should face the street.
- Campuses, which are generally composed of larger areas without public streets, should have a clear network of pedestrian paths and streets that encourage walking and biking, not driving, and allow neighboring pedestrians and bicyclists to cut through the campus.
- Setbacks in special use districts will vary based on the street and sidewalk character the buildings front; landscaping should be provided along public sidewalks and shade trees should be provided to reduce the effects of urban heat islands, which are common in highly paved industrial districts.
- Parking in special use districts could include on-street parking to buffer pedestrians from faster moving traffic, and where provided onsite should be connected to clear, safe pedestrian pathways.
- Loading docks and service functions should be designed to not conflict with pedestrian entrances from sidewalks into the facility.

## URBAN DESIGN

Urban design is the design of urban environments, whether in small villages, neighborhoods, town centers, or major urban districts. While sometimes used to describe just the selection of sidewalk patterns, benches, and streetlights, the term “urban design” is used here in its broadest and simplest sense: the design of environments in which people live, work, shop, and play.



*Urban design considers the relationship of site and building to the street, creates spaces for people, and can define the overall streetscape character (Credit: Lisa Padilla)*

“Land use” is commonly used as a rough synonym for urban design, and often as a substitute for words such as “building,” “business,” “parking lot,” or anything else that is located on a parcel of private property. In this manual, the term is used to refer to the “use” of the “land” in question. Urban design encompasses site design and street design along with the allowed uses within a certain block or district of a city, and defines the nature of people’s experience of that place. The design and use of



private development—collectively the “private realm” of the city—work in tandem with and shape the public realm of the city, defining the overall character of the place. When the design of the private and public realm work well together, the places they make are often experienced as “great streets” or “great places,” and desirable destinations.

Once the community decides on the desired character of the urban environment and the range of allowed land uses is determined, zoning regulations and development standards are prepared to support the desired type of place and street, so that the buildings that are developed (or are redeveloped) on each parcel play the appropriate supporting role in “completing the street.”



*The “public room of the street” is an important public space primarily shaped by the land uses and buildings that enclose it.  
(Credit: Cityworks Design and Michele Weisbart)*



Creating great streets with good private realm design starts at the initial phase of laying out a project on a site, including the location and design of the building(s) and the design of the access, parking, and landscape. The following principles are general and are written based on practices that support livable and healthy communities through (i) thoughtful site design, (ii) appropriate building forms, and (iii) good relationships between the building and the sidewalk and street that it fronts.

### THOUGHTFUL SITE DESIGN

The orientation of every building affects that building's relationship to people on the street. Each component of building demands careful site design. The following provide site design guidance:

- New projects or buildings developed on large parcels should form new blocks and streets that create a comfortable and walkable block size to help complete the network of streets (see Chapter 4, "Street Networks and Classifications").
- Buildings should be sited to support good connectivity to the center or neighborhood destinations that are nearby.
- Buildings should be oriented to the street to promote sidewalk activity and provide eyes on the street for the safety and comfort of pedestrians.
- The design of the site should minimize disruptions of pedestrian ways, whether sidewalks or mid-block passageways (typically by limiting the number and width of driveways).
- All buildings should be sited with their primary entries and fronts along the sidewalk, to encourage access from the sidewalk and on-street parking on foot.
- The number of driveways should be limited and consolidated. They should be no wider than necessary and designed to allow motorists to see pedestrians on the sidewalk.
- Parking lots and service entrances should be located toward the rear of the lot, accommodating automobiles but making it comfortable for people to access the buildings on foot.



*Thoughtful site design includes breaking up long blocks with attractive pedestrian paseos  
(Credit: Kimley-Horn and Associates, Inc.)*



- Wherever buildings are not built immediately adjacent to the public sidewalk, a coherent network of pedestrian routes should extend into the property so that pedestrians approaching from the street can access each building without walking through vehicular drives and parking lots.
- In all cases, the building pattern within a block should be designed to form comfortable, habitable outdoor spaces that promote a “sense of place” and a unique local character. Each building belongs to an individual or a business—the “community” is what happens between the buildings.
- The impacts of building form and site design on the larger neighborhood or district environment should be taken into consideration. For example, storm water can be managed on private property to reduce demands on the street infrastructure (collection and percolation), poorly functioning irrigation systems can be corrected (to minimize water waste and unnecessary run-off to the street), and building forms can be designed to provide access to fresh air and sunlight to their occupants and passersby on the sidewalk.

#### BUILDINGS’ RELATIONSHIP TO SIDEWALK

Each building directly interacts with the adjacent sidewalk on a micro level. The following provide guidance for designing buildings with sidewalks in mind:

- Buildings contribute to the overall character of the street by providing well-designed frontages and clear entry points from the sidewalk.
- For active mixed-use and commercial streets, building frontages should be mostly transparent with “active storefronts” that allow pedestrians to see into shops, restaurants, and public spaces.
- Along residential streets, building frontages should include windows overlooking the street with a layering of landscape, porch, patio, or semi-public space that buffers appropriately (setbacks will vary based on street typology and scale of the buildings).
- The primary building face should be located on the most active street frontage with an attractive and welcoming facade that includes entry doors, windows, signs, and other character-defining elements.
- The secondary building face that exists along a mid-block passage or side street should also include openings overlooking the public space.
- The tertiary (back) side of the building is located along a back alley or service drive where pedestrian movement is secondary to service, with loading docks, service entries, trash storage, and other unattractive functions accommodated here.
- Blank walls should be limited to the rear, and very limited along the secondary face.
- Lighting should be integrated into the building design to indirectly illuminate the sidewalk at night through (i) light filtering through storefront windows, and (ii) architectural lighting that features the building itself and enriches the street environment at night.



## APPROPRIATE BUILDING FORMS

Every building interacts with the street, so the details of key aspects of its form need careful consideration. The following provide building form design guidance:

### Walkable Streets



*Everything from the block size to the design of buildings and open spaces contributes to making walkable streets.*

*(Credit: Cityworks Design)*

- Building height, density, and setbacks are planned and designed to create a specific type of place that has a certain scale and character closely coordinated with the street typology.
- Building design standards should be developed to support a healthy street environment for pedestrians: for example, designing buildings to take into account how they interact with strong winds to create wind tunnels or unnecessarily restrict flows of natural light and air.
- On active mixed-use and commercial streets the design of the lower 3 to 4 floors should have an appropriate level of transparency and detail to support a great sidewalk environment for pedestrians.
- Buildings of 1 to 3 stories should be designed entirely at a pedestrian-oriented neighborhood scale, with features that can be appreciated by people walking or bicycling.



- Mid-height buildings of 4 to 6 stories should be designed at a pedestrian-oriented scale at the lower 2 to 3 floors and integrate windows, balconies, and other features that provide opportunities for occupants to overlook the street from upper floors.
- Taller buildings (over 6 stories) should generally have a base of lower floors designed similarly to those of mid-height buildings, and may benefit by stepping back from the frontage above this level to provide a street character that is not overwhelming to the pedestrian.
- In most mixed-use districts and neighborhood centers, it is more important to provide a relatively steady “street wall” to define a simple “street as an outdoor room” than to provide varied setback and stepbacks to “break up the mass” (see preceding section on streetscape environment types). In suburban environments where buildings stand free in the landscape, the desire to articulate the building form is understandable. But in urban districts and centers, the primary placemaking role of buildings is to calmly define the space of the place rather than to “express themselves” as unique objects.
- Towers in very dense districts (like an urban center) should be slender and mostly transparent, with a low to mid-rise base that provides pedestrian-oriented features. Towers should be designed to appear attractive and approachable from the street and sidewalk, not just to be an icon in the skyline.
- Parking should be integrated into the site and building design; ideally parking would be (i) underground, or (ii) tucked behind the building fronting the sidewalk and accessible from an alley or side street, or (iii) sited internally to the project or block so buildings “wrap it” to the greatest degree possible
- Buildings should be designed applying universal access principles (like locating stairs in prominent locations to encourage people to use them) making naturally legible paths through good design and an integrated site and building design approach.

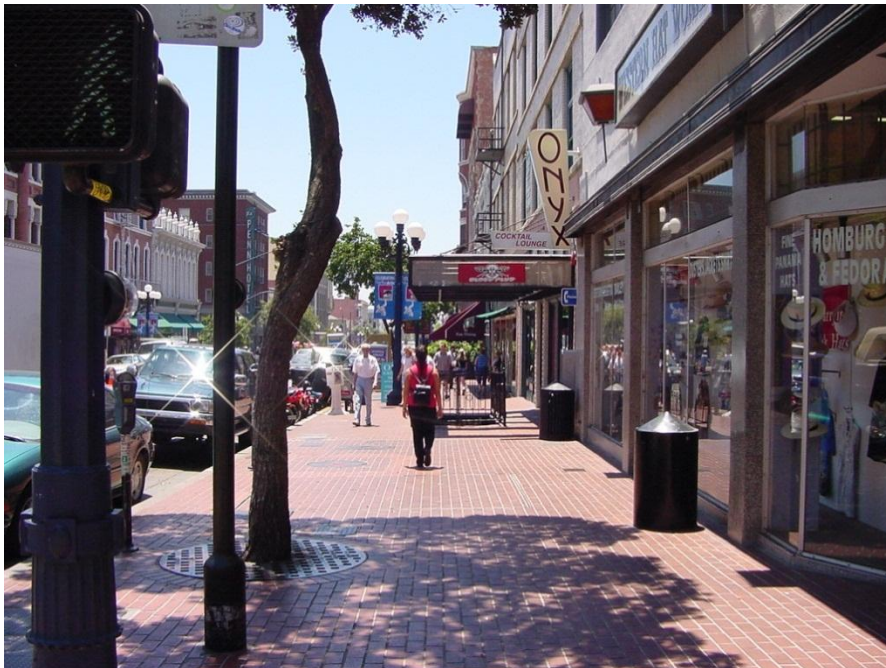

*Active ground floor uses  
(Credit: Ryan Snyder)*



## POTENTIAL IMPLEMENTATION STRATEGIES

Tools available to help implement good urban and architectural design that support the creation of good streets and great places include the following:

- Community-based vision plans, which are critical agreements or road maps that articulate how communities see their streets, neighborhoods, districts, and future growth.
- Create a resolution in support of Smart Growth and Complete Street Policies for your local government.
- Land Use Categories (Regional Activity Centers, Local Activity Centers, Transit Oriented Development, Transit Oriented Corridor, and Neighborhood Activity Center land use designations are all acceptable land use categories available for classification through the Broward Planning Council.
- Zoning standards that allow, encourage, and require a diverse mix of land uses that support the creation of sustainable, valuable places. Form based codes are suggested in mixed use zoning areas.
- Developing Regulating Plans for implementation of Form Based Code standards that include transportation, building and public space standards that are context based to the area.
- Standards and guidelines associated with this type of zoning that shape and coordinate development with street and that supports a healthy, pedestrian-centered lifestyle.
- Revise zoning use standards to permit fresh food markets, farmers markets, community gardens and urban gardens. Prohibit or reduce the amount of drive through and auto dominated uses located in the mixed-use centers, neighborhood centers and focus on multi-use provisions.
- Incorporate standards that address health and transportation access disparities in the long-term blueprint of a County or Municipality transportation system, such as a Long Range Transportation Plan or Comprehensive Development Master Plan.

## HEALTH AND LAND USE

Good land use planning and urban design can help create healthy neighborhoods with great streets and innovative and sustainable buildings. Some planning principles that should be considered include the following:

- Create a variety of places where people choose to walk and feel safe doing so—walking is an important form of daily exercise that can easily be integrated into the design of communities.
- Provide opportunities and incentives to create social environments in which all generations mix. These could include public or private facilities that accommodate both youth and senior activities, or planning development where adjacent uses allow different generations of the community to interact on a regular basis. By contrast, environments in which one must drive from one daily activity to the next systematically exclude the very young and the very old, who cannot drive and become “involuntary pedestrians” in environments designed for cars.
- Assure access to healthy foods and grocery stores; limit fast food establishments and allow drive-through service only in places where it is in the community’s best interests to have passersby shopping without turning off their engines.
- Capture opportunities for farmers’ markets – ideally on streets or within public spaces that are central and part of the local neighborhood street network.
- Look for underutilized public space to provide community gardens within neighborhoods, which will encourage gardening and social interaction and provide access to fresh produce.
- Integrate exercise routes and equipment into the network of streets, or even within underutilized roadway space (for instance, expanding neighborhood parkways where parking can be sacrificed, or a striped section of roadway that isn’t being used by cars but could be adopted for use by people).



*Outdoor sidewalk social environment with activities for all ages:  
 Venice, CA (Credit: Dan Burden)*



- Promote sustainable planning practices and building designs that help to preserve the environment through energy efficient design. Allowing residents and visitors to access the buildings without driving is the foundation of energy efficient design.
- Ensure complete bicycle networks and provide amenities within new projects to promote bicycling as appropriate to the scale of the project (bike racks, bike lockers, showers, or even a bicycle station).



*New development should be planned to promote sustainable design and integrate community gardens and open spaces that can be enjoyed by residents, or by pedestrians walking by.*

*(Credit: Bridge Housing, David Baker Architects)*



## BENCHMARKS

Good land use planning and urban and architectural design are best measured by how they complete the community’s vision for the specific place, and how they enhance the daily lives of their residents and users. Other qualitative and quantitative metrics that could be used to evaluate their effectiveness include the following:

- Jobs within a 15-minute commute by public transportation, bicycle, or walking
- Convenient shopping within comfortable walking or biking distance
- A school or park that a child can walk to/from home
- Useful transit within a 10-minute walk from home and/or work
- Clear zoning standards or design guidelines that help assure planning and design will be implemented as envisioned by the community
- Increased land values coming from the effective melding of transit, land use, and design
- The creation of great streets or places that people want to spend time in or live near
- Rates of diseases and health conditions associated with isolation, sedentary lifestyle, and air quality

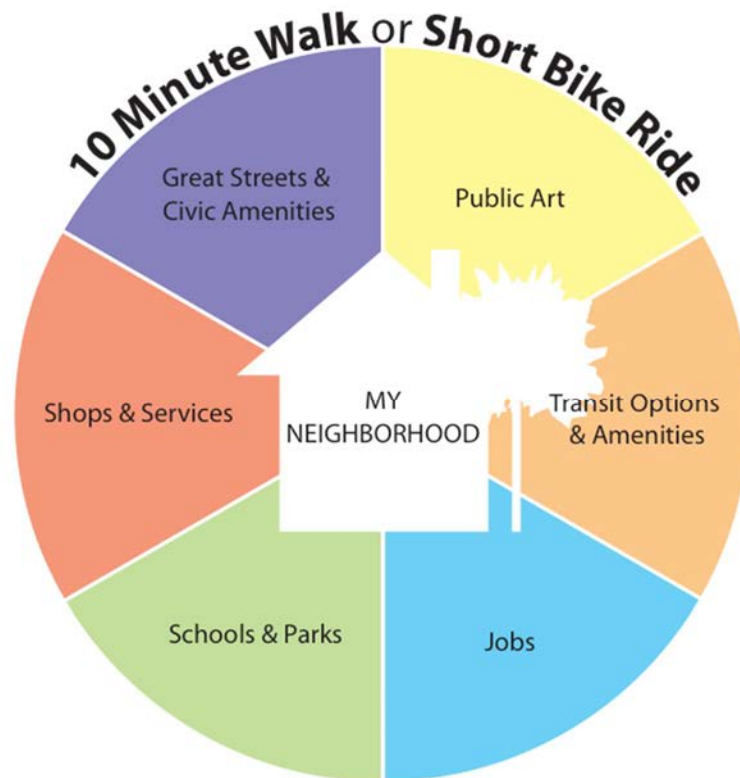

*Proximity of amenities in walkable neighborhood  
 (Credit: Cityworks Design)*

In Broward County, more than half of the residents surveyed felt there were too few stores and restaurants with an easy walk of their house. More than a third of participants stated distance



to destinations was the reason why they would choose to only travel by car. The majority expressed they would travel more often without a car if there were destinations within walking and biking distance (Urban Health Partnerships, In., *Broward Complete Streets Initiative Community Engagement Report*, 2012). Therefore, creation of great streets or places where people want to spend time will improve social capital, well-being, and physical health for the residents of Broward County.



## 15. RETROFITTING SUBURBIA

INTRODUCTION.....	1
SMART GROWTH.....	2
LIVABILITY .....	4
TRANSFORMING SUBURBAN STREETS TO COMPLETE STREETS.....	5
Changing Streets without Changing the Right-of-Way .....	5
Non-Physical Changes .....	8
Street Crossings.....	8
RE-ESTABLISHING STREET NETWORKS.....	9
SECOND-GENERATION LAND USE ALONG TRANSFORMED STREETS .....	11
SETTING PRIORITIES AND PHASING .....	12
MODEL PROJECT: BRIDGEPORT WAY.....	14
ADDITIONAL RESOURCES .....	16



*(Credit: Kimley-Horn and Associates, Inc.)*



## INTRODUCTION

Much of suburbia will have to change in order to thrive and meet the health, environmental, and economic challenges of the coming decades. Because of their form, widely separated land uses, and disconnected street networks, most suburban areas lack walkability and require that people travel by car for most of their needs. This has serious environmental consequences (poor air quality, climate change, and high energy consumption) as well as health consequences as suburbanites live in environments that discourage active transportation and social cohesion while favoring driving.

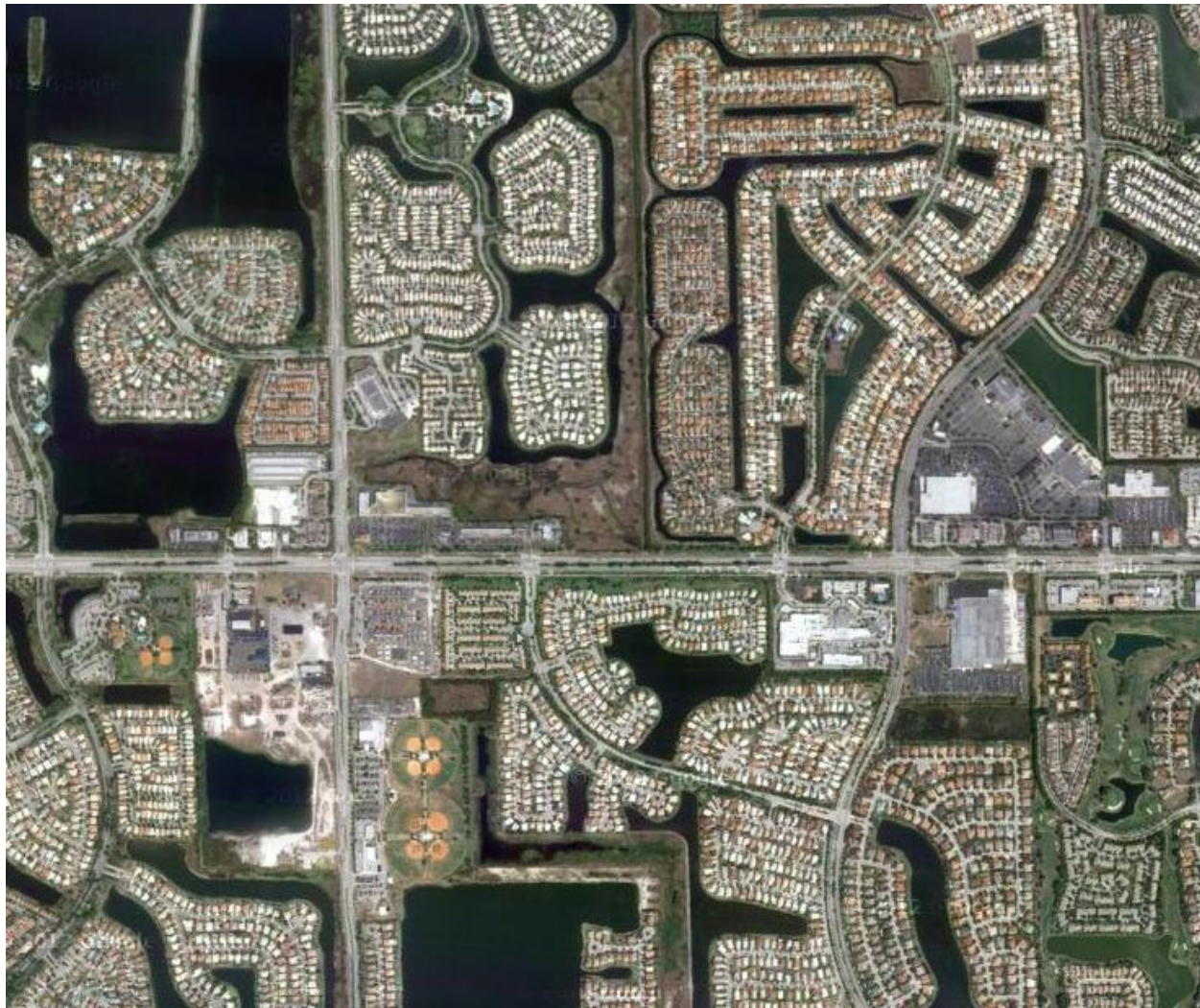

*Aerial view of typical suburban development pattern showing disconnected housing developments. The separation of houses from stores, schools, parks, and employment opportunities, results in long trip distances, which in turn creates a car-centric transportation pattern where almost every trip must use a busy arterial boulevard.*

*(Photo Source: Google Maps, Accessed May 23, 2012)*



Residents in these neighborhoods tend to become isolated due to the lack of walkable streets and walkable destinations. Rising fuel costs pinch both family budgets and local economies as people have less discretionary income.

Changing demographics also present challenges. Suburban homes have been built to accommodate young families with children, but fewer households now fit that profile. More and more households are comprised of empty nesters, young singles, divorced adults, and other non-nuclear families, and this trend is expected to grow in the future. Therefore, environments that foster social capital are more important than ever.



*Sidewalk on a suburban boulevard in Broward County near a bus stop*

*(Credit: Kimley-Horn and Associates, Inc.)*

As fuel prices continue to rise and as residents age, suburbs will need to serve more of their residents' needs closer to home, and serve those needs in places that can be accessed without a car. Suburban areas will need to be retrofitted to accommodate a new reality that rewards places that are close to more people and reachable in many ways. Economic and land constraints along with social desires are now motivating a return to a more compact development pattern with lower transportation costs. In South Florida, this motivation is leading to a polycentric land development pattern where clusters of density are taking shape in many areas.

This chapter describes how streets can support retrofitting suburbia, provides strategies for retrofitting streets, and recommends priorities and phasing. All of the changes recommended in this chapter will improve safety. The first priority for a local jurisdiction beginning to retrofit itself for the future should be to find and fix the places that are unsafe.

## SMART GROWTH

Smart growth as a comprehensive development concept will play a vital role in helping to retrofit suburbia to become more sustainable. In Broward County, the Smart Growth Partnership is already working to achieve these goals. According to the Broward Complete Streets Initiative public survey, one-third of a diverse group of Broward County residents stated they were familiar and could reiterate one or more Smart Growth principles. These respondents were twice as likely (OR=2.69) of preferring houses that were built closer together on smaller lots ( $p < .000$ ). The following information is from the website for the Smart Growth Partnership ([www.smartgrowthpartnership.org](http://www.smartgrowthpartnership.org)).



“Smart Growth”, a comprehensive approach to development used in many cities across the nation, incorporates the following principles.

- **Enhance Quality of Life.** Smart Growth communities are designed to attract a diverse population of residents and businesses – then keep them there, with pedestrian-oriented walkable neighborhoods, diverse housing, and an array of local businesses and services. Nearby resources minimize car trips and maximize walking, bicycling, and person-to-person interaction. Its compact land-use planning at its best, including commercial, office, public, and recreational uses.
- **Promote Economic Development.** Attract businesses and jobs to locations near housing, infrastructure, and transportation options. Promote economic development in industry clusters. Expand access to education, training, and entrepreneurial opportunities. Support the growth of local businesses, including sustainable natural resource-based businesses, such as agriculture, forestry, clean energy technology, and fisheries.
- **Create Livable Communities.** Support the revitalization of city and town centers and neighborhoods by promoting development that is compact, conserves land, protects historic resources, and integrates uses. Encourage remediation and reuse of existing sites, structures, and infrastructure rather than new construction in undeveloped areas. Create pedestrian-friendly districts and neighborhoods that mix commercial, civic, cultural, educational, and recreational activities with open spaces and homes.
- **Promote Alternative Transportation.** Maintain and expand transportation options that maximize mobility, reduce congestion, conserve fuel and improve air quality. Prioritize rail, bus, boat, rapid and surface transit, shared-vehicle and shared-ride services, bicycling, and walking. Invest strategically in existing and new passenger and freight transportation infrastructure that supports sound economic development consistent with Smart Growth objectives.
- **Create a Range of Housing Opportunities.** Support the construction and rehabilitation of homes to meet the needs of people of all abilities, income levels, and household types. Build homes near jobs, transit, and where services are available. Foster the development of housing, particularly multifamily and smaller single-family homes, in a way that is compatible with a community's character and vision and with providing new housing choices for people of all means.
- **Preserve Open Space, Natural Resources, and the Environment.** Protect and restore environmentally sensitive lands, natural resources, agricultural lands, critical habitats, wetlands and water resources, and cultural and historic landscapes. Increase the quantity, quality and accessibility of open spaces and recreational opportunities

These Smart Growth principles have been developed to help South Florida meet the needs of our current and future communities by revitalizing neighborhoods, preserving natural areas,



stimulating economic development, and providing transportation alternatives to the car. A model Smart Growth resolution is available for review in Appendix C.

## LIVABILITY

The concept of livability is focused on creating ways to increase the economic prosperity of neighborhoods, reduce commute times to work and recreational activities, and also reduce pollution. Livability is a way to add sustainability to the places where the following principles are incorporated. The following information is from the Partnership for Sustainable Communities website ([www.sustainablecommunities.gov](http://www.sustainablecommunities.gov)).

The following six principles comprise the concept of livability.

- **Provide More Transportation Choices.** Develop safe, reliable, and economical transportation choices to decrease household transportation costs, reduce our nation's dependence on foreign oil, improve air quality, reduce greenhouse gas emissions, and promote public health.
- **Promote equitable, affordable housing.** Expand location- and energy-efficient housing choices for people of all ages, incomes, races, and ethnicities to increase mobility and lower the combined cost of housing and transportation.
- **Enhance Economic Competitiveness.** Improve economic competitiveness through reliable and timely access to employment centers, education opportunities, services and other basic needs by workers, as well as expanded business access to markets.
- **Support Existing Communities.** Target federal funding toward existing communities – through strategies like transit-oriented, mixed use development and land recycling – to increase community revitalization and the efficiency of public works investments and safeguard rural landscapes.
- **Coordinate and Leverage Federal Policies and Investment.** Align federal policies and funding to remove barriers to collaboration, leverage funding, and increase the accountability and effectiveness of all levels of government to plan for future growth, including making smart energy choices such as locally generated renewable energy.
- **Value Communities and Neighborhoods.** Enhance the unique characteristics of all communities by investing in healthy, safe, and walkable neighborhoods – rural, urban, or suburban.



## TRANSFORMING SUBURBAN STREETS TO COMPLETE STREETS

Streets play an enormous role in determining a place's quality of life. Everywhere in the country, people prefer a certain kind of street ("*Redefining Charlotte's Streets*," Urban Street Design Guidelines, Charlotte, North Carolina, 10/22/2007). People's favorite streets include those with the following characteristics.

- An abundant tree canopy and other streetscape features
- Sidewalks and buffering from traffic
- Moderate traffic speeds
- All kinds of uses (walking, cycling, driving, and enjoying the lawns or sidewalks and patios on either side)

People need not know the term "complete street" to recognize and enjoy one.

The least favorite streets are those where driveways, parking lots, and utility poles are more abundant than trees and people. They often consist of wide expanses of pavement for moving traffic, and make little or no provision for any other users. In particular, there is little opportunity to cross the street.

The challenge for local governments with too many least favorite streets is to transform them into most favorite, complete streets.

### CHANGING STREETS WITHOUT CHANGING THE RIGHT-OF-WAY

By definition, a retrofit occurs on an existing street. This manual gives design guidance for all streets, existing and new. The following section recommends how to accommodate those design recommendations on *existing* streets. Many aspects of complete streets actually take *less* space than typical suburban design.

To create a complete street in the right-of-way of an existing street, local governments should utilize the following strategies (LaPlante, J., "*Retrofitting Urban Arterials Into Complete Streets*," 3rd Urban Street Symposium, June 24-27, 2007, Seattle, Washington).

- **Narrow travel lanes.** Ten or 11-foot lanes are acceptable for most urban boulevards. They are just as safe as 12-foot lanes for posted speeds of 35 mph or less (Dumbaugh, E., "*Safe Streets, Livable Streets*," Journal of the American Planning Association 71[3] 283-300). Narrowing travel lanes to create complete streets elements is consistent with the Florida Department of Transportation (FDOT) Plans Preparation Manual (PPM) Chapters 8, 21, and 25, which reference narrowing travel lanes for the purpose of creating bike lanes. Furthermore, an FDOT Central Office study found that narrowing inside travel lanes to provide more space for bicyclists on the outside of the roadway



produced positive safety benefits for all users including reduced conflicts and greater passing separation afforded by motorists when performing an overtaking maneuver.

- **Seek opportunities to put streets on a road diet.** This strategy involves eliminating superfluous travel lanes. Common scenarios include the following.

- Convert a four-lane undivided road to a three-lane road with bike lanes (two-way left-turn center lane, two motor vehicle travel lanes, and two bike lanes). This configuration can handle up to 18,000 ADT and improves safety and access to adjacent destinations; the two-way left-turn center lane can be replaced with short sections of medians and pedestrian crossing islands in selected locations. On-street parking can be substituted for bike lanes where the context and conditions warrant.

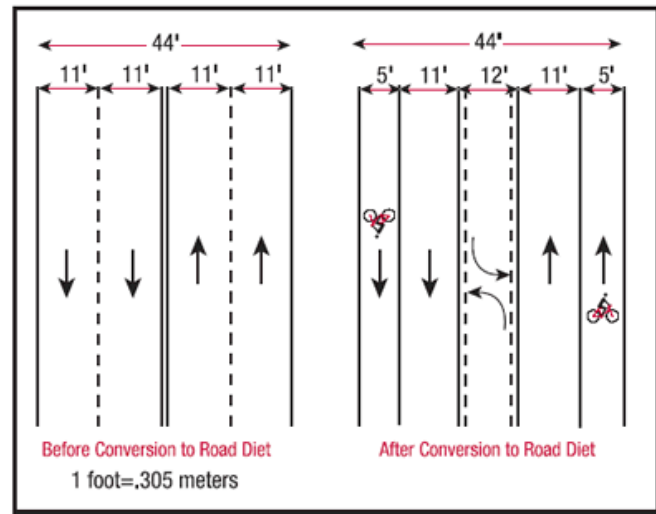

Example of a 4-lane to 3-lane road diet with bike lanes  
(Credit: Federal Highway Administration)



Simulation of the positive result of a 4-lane to 2-lane road diet with bike lanes and on-street parking  
(Credit: Kimley-Horn and Associates, Inc.)

- Reduce seven-lane roads to five lanes for ADTs of up to 35,000 utilizing a similar strategy as presented in the previous point.



- Remove a travel lane from three- and four-lane one-way streets. Two-lane one-way streets can handle around 21,000 ADT. Three-lane one-way streets can handle around 32,000 ADT.
- Reduce six-lane boulevards to four lanes for ADT's of up to 35,000. This strategy has been studied extensively by FDOT and the City of Fort Lauderdale for a section of State Road A1A between Oakland Park Boulevard and Flamingo Avenue. The study found negligible impacts on motor vehicle capacity while providing a valuable opportunity to add greenway and complete streets elements. The study produced a plan that was accepted by FDOT and the City, and this road diet project is currently in the design phase.
- **Tighten corner curb radii to the minimum needed to provide a usable turning radius for an appropriately selected design vehicle.** Occasional encroachment by larger vehicles into other travel lanes is acceptable; intersections should not be designed for the largest occasional vehicle.
- **Eliminate unnecessary turn lanes at intersections.** An example is a right-turn lane with very few right turning vehicles (fewer than 100 per hour). Free-flow right-turn lanes, including freeway entry and exit ramp connections to surface streets, should be replaced with yield control.
- **Replace painted channelization islands at intersections with raised islands.** This gives pedestrians a true refuge and breaks up a long crossing of many lanes into smaller discrete steps.



*Curb extensions with tight corner radii and outdoor seating  
 (Credit: Dan Burden)*

All of these changes can free up space, which can be used for additional elements. To improve street quality, local jurisdictions can incorporate the following elements or others included in other chapters of the *Broward Complete Streets Guidelines*.

- Add green colored pavement bike lanes or cycle tracks.
- Add or widen sidewalks.
- Add raised medians, which visually narrow the roadway and provide a median refuge for midblock crossings.
- Provide median and parkway landscaping, which further visually narrows the roadway and provides a calming effect.



- Add or retain curb parking, which improves community access, calms traffic, and buffers pedestrians.
- Add bulb-outs, which shorten pedestrian crossing distances and improve sight lines.

### NON-PHYSICAL CHANGES

In addition to physical retrofits, local governments can and should adapt existing street management and operations to

- Adjust signal timing for slower speeds and to ensure comfortable crossing times for appropriate populations. In areas with aging populations, for example, crossing times may need to be lengthened. The Institute of Transportation Engineers (ITE) Recommended Practice, *Designing Walkable Urban Thoroughfares: A Context Sensitive Approach*, recommends using 2.8 feet per second in areas with aging populations.
- Work with transit agencies to improve bus operations
- Work with schools to develop a Safe Routes to School Program
- Reexamine the parking code (for example, off-street parking requirements may be reduced, especially in coordination with additional on-street parking)
- Work with housing authorities and aging alliances to develop Safe Routes Around Home targeted towards older adults.
- Incorporate standards that address health and transportation access disparities in the long-term blueprint of a local jurisdiction’s transportation system, such as a Long Range Transportation Plan or Comprehensive Development Master Plan.

### STREET CROSSINGS

A connected sidewalk network includes street crossings. See Chapter 6, “Intersection Design,” and Chapter 8, “Pedestrian Crossings,” for design details. To improve street crossings, jurisdictions can consider the following:



- Make pedestrian crossing locations safe, comfortable, and more frequent (LaPlante, J., “Retrofitting Urban Arterials Into Complete Streets,” 3rd Urban Street Symposium, June 24-27, 2007 Seattle, Washington).
- Allow crossing at every corner of all intersections.
- On streets with a bus route, make provisions for pedestrians to cross

*Crossings should be designated on every leg of all intersections in an urban context  
 (Credit: Kimley-Horn and Associates, Inc.)*



the street at all bus stops. Bus riders need to cross the street either coming or going.

- Provide mid-block crossings. Pedestrians should not be expected to travel to the closest signalized intersection to cross the street when signalized intersections in suburban and urban areas are often spaced ¼ mile, ½ mile, or even further apart; it is unreasonable to expect people to walk that far to cross the street. Nor do signalized intersections offer complete safety protection benefits to pedestrians, due to the many added turning conflicts at large suburban intersections.

Many of these changes can be made through spot improvement programs. Many are relatively inexpensive; it is not necessary to wait for a reconstruction to create a complete street. More substantial retrofits may require reconstruction (see the Model Project section at the end of this chapter). A planned surface repaving project is an excellent time to retrofit the corridor to add comfort, convenience, safety, aesthetics, and economic value.

### RE-ESTABLISHING STREET NETWORKS

Chapter 4, “Street Networks and Classifications,” details the need for interconnected street networks with short blocks. Much of today’s suburban landscape was built in isolated pods: residential subdivisions, business parks, shopping centers, and schools that are poorly connected to neighboring properties. These pods create barriers to getting around other than in a car, because they create long distances between destinations and because the pods are often surrounded by sound walls, fences or berms, literally blocking potential bicycle and walking routes. These pods don’t work well for auto traffic either, since they force all traffic onto busy streets rather than allowing connection and local circulation through local streets.

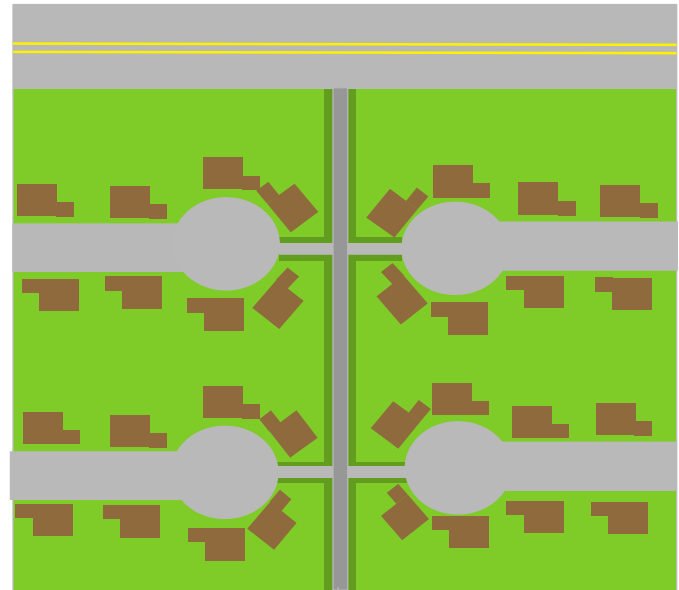

Connecting cul-de-sacs (Credit: Marty Bruinsma)

***“I can travel by walking but not easily because I live in a gated community with only two inconvenient entry/exit gates.”***

- (Broward Complete Streets survey respondent)

To create a vibrant suburb that will thrive in new conditions, direct connections must be created or re-created to enable efficient, direct travel by everyone. That means establishing or re-establishing street and sidewalk networks. Re/establishing a street network can be more challenging, particularly when right-of-way has not been preserved. Some local governments have purchased homes at the end of cul-de-

sacs, put the connectors in, and then sold the homes. In cases where a local government is still developing suburbs, it should make connectivity a fundamental priority by following the principles in Chapter 4, “Street Networks and Classifications.”



Cul-de-sacs break up connections.  
 (Credit: PB Americas, *EWA Connection Study*, May 2009)



Pedestrian networks can be re-established by opening noise walls and connecting new sidewalks. (Credit: PB Americas, *EWA Connection Study*, May 2009)



*Pedestrian connector path between buildings, Coconut Creek Promenade*  
 (Credit: Kimley-Horn and Associates, Inc.)

*Bicyclists on a connector path between two street rights-of-way*  
 (Credit: Kimley-Horn and Associates, Inc.)





## SECOND-GENERATION LAND USE ALONG TRANSFORMED STREETS

Not only streets will need to change in suburbia; many land uses are obsolete and/or no longer economically viable. However, street improvements generally should come before land use change in suburban retrofitting. This is because *high-quality land uses come to high-quality streets*. Very rarely will high-quality land uses come to low-quality streets.

The street and the land use work together and determine whether a place is attractive and draws people and investment. To that end, communities retrofitting older suburban areas would do well to use the following three principles:

### 1. Focus new investment in nodes on streets.

In most of suburbia, there will not be enough investment all at once to transform whole corridors. Identify and focus investment at individual nodes. A good example of this strategy is the Downtown Coral Springs plan centered on the important node at University Drive and Sample Road.

### 2. Focus revitalization efforts on creating genuine places in those nodes: compact, mixed-use, transit-oriented, and at least internally walkable.

Plan for and enable neighborhood-serving commercial districts. Where necessary, rezone from automobile-oriented commercial sites (gas stations, convenience stores, and fast food outlets). These car plazas are designed for, and dependent on, vehicular access and offer no relationships with the nearby residential areas. They absorb retail potential and will tend to discourage development of neighborhood-serving commercial districts.

### 3. Carefully detail the desired outcomes.

It is vital that retrofit efforts pay attention to the details described in the individual chapters of the *Broward Complete Streets Guidelines*. Adopting well-intentioned policy goals is not enough. There must be follow through by incorporating the vision's details in the design and construction of the project. Desired outcomes may include reduce vehicle miles traveled (VMT), reduce greenhouse gas emissions (GHG), increase transit ridership, and development consistent with established smart growth principles.



Infill development between nodes that follows the principles of this document will help to connect the nodes into livable neighborhoods.



*Conversion of shopping center to a neighborhood  
 (Credit: Michele Weisbart)*

## SETTING PRIORITIES AND PHASING

The primary challenge in retrofitting suburbia is less fixing the infrastructure and more creating economically sustainable places, with the emphasis on place.

As suggested above, the priority should be to begin by creating vibrant nodes. Local jurisdictions should not allow themselves to be daunted by the scale of the retrofit challenge.

Take advantage of opportunities. Only a small sample of current opportunities are listed below.

- The growing popularity of smart growth and place-making as development concepts.
- Increased interest for in-town living.
- Public-private partnerships.
- Transit-oriented development (TOD).

As with street retrofits, creating places can be done incrementally. The images on the next page show such an incremental process.



*Example of a transformed suburban street (Credit: Urban Advantage, Inc.)*



## MODEL PROJECT: BRIDGEPORT WAY

Before reconstruction, Bridgeport Way in University Place, Washington, was a classic auto-oriented suburban arterial street. The existing street had a high accident rate, and did not support economic growth; it attracted neither people nor investment.



*Bridgeport Way before transformation: University Place, WA (Credit: Dan Burden)*

After reconstruction, the corridor served more people, was far safer, and drew economic development.



*Bridgeport Way after transformation: University Place, WA  
(Credit: Michael Wallwork)*



Safety improved significantly:

- 7% speed reduction (35.3 -> 33.4 mph)
- 60% crash reduction (19 -> 8 in five blocks)

Bridgeport Way illustrates the principle described above of leading with a street retrofit, then following with bringing higher-quality land uses to the now high-quality street.

The City of University Place identified empty, redevelopable space along the corridor and at intersections. The photo below shows ample space that has been used for parking, building setbacks, and other uses.



*Bridgeport Way transformation opportunities: University Place, WA  
(Credit: Michael Wallwork)*



The City planned for new development that would create a new *place*, as shown in the rendering below.



*Bridgeport Way plan: University Place, WA (Credit: City of University Place)*

## ADDITIONAL RESOURCES

American Planning Association (APA). *The Transportation / Land Use Connection*, APA Report Number 546/547, June 2007.

Institute of Transportation Engineers. *Smart Growth Transportation Guidelines*, 2010.

ICF International with Nelson\Nygaard Consulting Associates and Reid Ewing. *Transportation Study of the U.S. Route 1 College Park Corridor*, July 14, 2008.

PB Americas, *EWA Connectivity Study*, May 2009.

Dunham-Jones, E. and Williamson, J., *Retrofitting Suburbia: Urban Design Solutions for Redesigning Suburbs*, John Wiley & Sons, 2009. This book focuses more on retrofitting parcels of land, rather than on the streets between them. Nonetheless, it is an excellent resource.



**APPENDIX A:  
BROWARD COMPLETE STREETS INITIATIVE  
COMMUNITY ENGAGEMENT REPORT**



This page left blank intentionally.



Broward  
*Complete Streets*  
Initiative



COMMUNITY  
ENGAGEMENT REPORT

*Safer, Healthier Streets for ALL Users*  
[www.BrowardCompleteStreets.org](http://www.BrowardCompleteStreets.org)



This publication was supported by the Cooperative Agreement Award Number U58DP003661-01 from the Centers of Disease Control and Prevention. Its contents are solely the responsibility of the authors and do not necessarily reflect the official views of the Centers of Disease Control and Prevention.

# COMMUNITY ENGAGEMENT REPORT

June 2012

[www.BrowardCompleteStreets.org](http://www.BrowardCompleteStreets.org)

Broward  
Complete Streets  
Initiative



## TABLE OF CONTENTS

Acknowledgements.....	3
<b>CHAPTER I: EXECUTIVE SUMMARY.....</b>	<b>5</b>
Background.....	5
Summary of Findings.....	6
Summary of Recommendations.....	7
<b>CHAPTER II: PUBLIC INVOLVEMENT PLAN.....</b>	<b>9</b>
<b>CHAPTER III: BROWARD SMART GROWTH &amp; COMPLETE STREETS SURVEY.....</b>	<b>10</b>
Travel Behaviors.....	11
3 Foot Passing Law.....	15
Smart Growth.....	15
<b>CHAPTER IV: PUBLIC WORKSHOP SERIES.....</b>	<b>18</b>
City of North Lauderdale.....	18
City of West Park.....	19
Nova Southeastern University.....	20
Workshop Feedback.....	20
<b>CHAPTER V: PRESENTATIONS &amp; FOCUS GROUP DISCUSSIONS.....</b>	<b>25</b>
City of Deerfield Beach, Highland Garden Community.....	25
City of West Park, Carver Ranches Public Library After-School Program.....	26
<b>CHAPTER VI: MEDIA REPORT &amp; PUBLIC DISCOURSE.....</b>	<b>27</b>
<b>CHAPTER VII: SUMMARY OF KEY FINDINGS AND RECOMMENDED STRATEGIES.....</b>	<b>28</b>
Summary of Key Findings.....	28
Strategy 1: Enhance Quality of Life by Implementing Complete Streets.....	29
Strategy 2: Complement Complete Streets design with Smart Growth Principles.....	31
Strategy 3: Advocate for the Expansion of Multi-modal Transportation.....	31
Strategy 4: Address the Needs of Older Adults.....	32
Strategy 5: Incorporate and Expand Programs and Policies Focused on Youth.....	33
Strategy 6: Utilize Social Marketing to Shift Cultural Norm.....	34
Strategy 7: Educate Policy-Makers, Engage Stakeholder and Establish Coalitions.....	35
<b>Appendix A: TECHNICAL ADVISORY COMMITTEE MEMBERS.....</b>	<b>37</b>
<b>Appendix B: COMMUNITY RESOURCES.....</b>	<b>38</b>
<b>Appendix C: ENDNOTES &amp; PHOTO CREDITS.....</b>	<b>39</b>

## Acknowledgements

This report represents the work of Urban Health Partnerships, a South Florida not-for-profit organization committed to leading ongoing, community-based initiatives to develop sustainable systems and protocols that improve health outcomes and reduce disparities across the life span. The Broward Regional Health Planning Council was awarded a Community Transformation Grant by the Centers for Disease Control and Prevention, locally known as the Transforming Our Community's Health (TOUCH) Initiative. The TOUCH Healthy and Safe Physical Environment component was subcontracted to Urban Health Partnerships (UHP), Smart Growth Partnership, and the Broward Metropolitan Planning Organization (MPO). Urban Health Partnerships' primary task was to lead the Broward Complete Streets Initiative, create a Complete Streets guidance document and assist the MPO with its institutionalization. Smart Growth Partnership complemented this effort by providing technical assistance to the 31 municipalities interested in adopting and implementing both Complete Streets policies and Smart Growth principals and codes.

In addition to Smart Growth Partnership and Broward MPO, several individuals and organizations have collectively volunteered more than 150 hours - engaging the community and ultimately bringing this document into fruition. UHP extends their sincere gratitude to the following:

- Complete Streets Technical Advisory Committee of Broward MPO (Appendix A). Members were actively involved in participating and promoting the Public Workshop series, online survey, and providing feedback on the Public Involvement Plan implementation.
- Nova South Eastern University Department of Public Health, Nicole Cooke, PhD Professor and TOUCH Evaluator, Lucas Hollar, PhD Professor and TOUCH Evaluator, Lauren Bello, MPH Student, Focus Group Facilitator and Public Workshop Volunteer, Shira Fowlkes, Focus Group Assistant Facilitator and Public Workshop Volunteer and Kamara Camille Salmon, Feedback Survey Evaluator.
- Florida Department of Transportation -District 4 office whose staff assisted in providing extensive feedback and promotion of the online survey.

- The Broward Cities of North Lauderdale, West Park, and Deerfield Beach as well as Carver Ranches Public Library and the Broward County Housing Authority's Highland Gardens Development who seamlessly assisted with the coordination of presentations, focus groups, and public workshops.
- Stewart Robertson from Kimley-Horn and Associates who went above and beyond to assist in the completion of this project.
- Broward Regional Health Planning Council for providing guidance at each step and staff to assist in the public workshop series.
- Prevention and Public Health Fund (PPHF) of the Affordable Care Act for authorizing the Centers for Disease Control and Prevention Communities Transformation Grant program to support community-level efforts to reduce chronic disease] such as heart disease, cancer, stroke, and diabetes, and for garnering national focus on the connection between health and the built environment.

Additional products produced by UHP as a result of the cooperative agreement award number U58DP00361-01 from the Center for Disease and Control and Prevention can be found at [www.BrowardCompleteStreets.org](http://www.BrowardCompleteStreets.org) and [www.TOUCHBroward.org](http://www.TOUCHBroward.org).

# CHAPTER I: EXECUTIVE SUMMARY

**Background** The aim of the Broward Complete Streets Initiative is to develop healthier and safer streets for multi-modal transportation use which includes walking, biking, the use of wheelchairs or assisted walking devices, and/or the use of public transportation in Broward County. Complete Streets aims to increase health in a community through the promotion of physical activity, social interaction and accessibility. Adversely, incomplete streets restrict physical activity and maintain barriers to an active, interactive lifestyle. Further, the design is targeted toward combating obesity – an increasing national epidemic – prevalent in South Florida. As the number of individuals affected by obesity consistently rises, physical activity remains a key recommendation to minimize obesity-related illness. Obesity is highly correlated with low rates of physical activity with one key study citing “on a daily basis, each additional hour spent driving is associated with a *6% increase* in the likelihood of obesity, while each additional kilometer walked is associated with a *5% reduction* in this likelihood.” Complete Streets additionally focuses on developing a pleasant and safe environment to motivate an active lifestyle. Safety has been associated with physical activity frequency as well with one study revealing that 43% of those with safe places to walk within 10 minutes of their homes reached their recommended levels of physical activity, while only 27% of those without safe places to walk met the recommendation. Public transportation is a final and integral component of the Complete Streets model which connects individuals and encourages greater use of multi-modal transportation. The Complete Streets design allows for easy access to public transportation, which has been found to help increase physical activity (<http://www.completestreets.org/complete-streets-fundamentals/factsheets/health/>).

A healthy and safe physical environment can build social capital, which is the system that inspires trust and reciprocity among community members. Studies conducted by Dr. Kevin M. Leyden demonstrate that individuals living in livable, walkable, mixed-use neighborhoods have higher levels of social capital. These individuals tend to be less isolated and more involved in their community. Social capital has additionally been linked with improved health, lower crime, and economic prosperity outcomes. Therefore, in addition to supporting physical health, Complete Streets also promotes aging in place and positive mental health and well-being across the life span.

To initiate the process of gauging community interest in the development of Complete Streets in Broward County more than 2,000 Broward County residents and/or employees participated in a survey, public workshop, presentation, and/or focus group related to Complete Streets from February through May of 2012. This valuable feedback was incorporated into, and used to guide the development of the *Broward Complete Streets Guidance Document*. The following report summarizes the tactics used to gather information and results of their responses and perceptions, as well as recommendations for further exploration.

**Summary of Findings** The majority of the approximately 2,000 Broward County, Florida residents of diverse professions and adult ages, underscored that they would like to see more sidewalks, public transit near their homes, bike lanes with painted white lines, destinations within walking or biking distance, and safe routes while commuting without a car. According to participants, there are currently not enough places to bike nor public transportation options within an easy walk for Broward residents. Two-thirds of residents who stated they would never travel without a car in current conditions would consider walking and biking to nearby destinations, if Complete Streets elements were incorporated in the right-of-way. These elements would include age- and ability-appropriate infrastructure that would result in a convenient, safe transportation environment. If alternative modes of transportation were readily provided through implementation of Complete Streets, 90% of respondents would consider traveling to nearby destinations without a car.

Analysis revealed several positive associations between distance, lack of public transport and individuals' choice to elect driving over alternative forms of travel. There was a higher likelihood of residents using their vehicles when short distances (less than one mile) were perceived as not walkable and public transport considered limited. These decisions were not associated with age or gender. Area housing was also positively associated with respondents' decision to drive over alternative transport. These data support the need for a comprehensive approach involving expanding public transport options and awareness, improving bicycle facilities and sidewalk access and maintenance, and increasing connectivity and accessibility from homes to daily destinations.

While national research supports positive health outcomes resulting from the shift away from the cultural norm of automobile dependence to active transportation, local findings demonstrate the task will require a multi-sector, long-term commitment in Broward County. The Broward Complete Streets Guidance document, championed by the Metropolitan Planning Organization and the Broward Regional Health Planning Council, lays the foundation for implementation of infrastructure and non-infrastructure projects and programs that can enhance the active transportation agenda and create a safe and healthier physical environment for Broward County.

***Summary of Recommendations Recommended Strategies*** The findings from the survey and other community engagement activities revealed a clear direction for recommended strategies. The following recommendation subsections were compiled to guide community members and community partners in the implementation of Complete Streets: Enhance Quality of Life by Implementing Complete Streets, Complement Complete Streets design with Smart Growth Principles, Advocate for the Expansion of Multimodal Transportation, Address the Needs of Older Adults, Incorporate and Expand Programs and Policies Focused on Youth, Utilize Social Marketing to Shift Cultural Norm, and Educate Policy-Makers, Engage Stakeholders and Establish Coalitions.

Strategies and recommendations were formulated with the goal of underscoring and addressing key elements and populations specific to Broward County. The suggested target demographics to additionally be considered in the development of a Broward County plan are older adults, who compose a large percentage of the population, as well as local youth. It is recommended that the needs of the elderly be explored and considered and also that expanding Safe Routes to School Programs be incorporated into design as a fundamental component of Complete Streets. To bolster local support it is further recommended that community stakeholders engage as advocates for the expansion of multi-modal transportation, Complete Streets leaders educate local policy-makers and establish coalitions in support of neighborhood Complete Streets. To further complement Complete Streets design it is recommended that Smart Growth principles be employed in the developmental phases. Social Marketing should be utilized to encourage a shift in cultural norm as many studies cite difficulty in behavioral change with infrequent exposure or promotion to a new concept or behavior.

Finally, it is strongly recommended that Complete Streets implementation be flexible and build upon existing infrastructure to enhance quality of life through the improvement of physical activity options and social interaction to positively impact both physical and mental well-being. The use of research and assessment to measure and quantify affects for sustainability and continuous improvement should be incorporated in every Complete Streets plan.

## CHAPTER II: PUBLIC INVOLVEMENT PLAN

In February 2012, a Public Involvement Plan (PIP) for the Broward Complete Streets Initiative was formulated. The purpose of the PIP was to guide the team on introducing the Complete Streets concept and its relation with health to Broward County stakeholders, obtain the public's perceptions of their current environment and their existing travel behaviors and needs, and identify opportunities to incorporate Complete Streets policies and practices. The results of this process will be incorporated in the *Broward Complete Streets Guidance Document*, which is being adopted from the Centers for Disease Control and Prevention (CDC) funded *Model Design Manual for Living Streets for Los Angeles*. In addition, the recommendations will highlight ways to engage all residents in the utilization and formation of Broward streets.

**Public Involvement Plan Elements** The overarching goal of the PIP was to gauge the community's knowledge and interest while increasing their awareness about the value of creating a built environment that balances the needs of all modes of transportation. Ultimately, the goal was to generate support for the endorsement and implementation of Complete Streets policies and practices. Seven strategies accompanied by a series of comprehensive tactics and measurement tools were used to inform stakeholders, engage the public, and obtain valuable feedback from a wide range of community members and relevant professionals (Figure 1). Presentations, public workshops, and discussion groups geared towards decision makers, technical advisory boards - consisting of engineering, planners, transportation and health professionals as well as elders, adults with disabilities and elementary and college students were conducted over a five month period. Data was collected via social media outlets, online surveys, and in-person interactions.

**Figure 1. Public Involvement Plan Elements**



# CHAPTER III: BROWARD SMART GROWTH & COMPLETE STREETS SURVEY

A total of 1,609 Broward Smart Growth & Complete Streets Surveys were completed between February and May of 2012. Each percentage is based on the number of respondents for each specific question. The majority of respondents (98%) lived and more than half (66%) worked in Broward County. Although a third self-reported being older than 56 years-of-age, only 1% identified themselves as retired or semi-retired. Half of respondents were between the ages of 35 and 55, and 15% were younger than 35. There was an equal representation of males (50%) and females (48%). The greatest number of respondents (a minimum of 15 per zip-code) were from the following areas and cities: *North Broward* (n=207): North Lauderdale, Pompano Beach, Parkland, and Coral Springs; *Mid Broward* (n=567): Fort Lauderdale, Cooper City, Dania Beach, Wilton Manors, Davie, Sunrise, Weston, and Plantation; *South Broward* (n=351): Hollywood, Hallandale Miramar, West Park and Pembroke Pines. Additional cities and zip codes within Broward County made up for a third of the respondents.

The most prominent occupations among respondents (n=1,299) were engineers, planners, designers and architects (14%), high-level management such as directors, CEO, and presidents (11%), office administration, secretarial and clerical positions (8%), health (7%), academia and school teachers (6%) and accountants (5%). The remaining 49%, were a wide range of professions such as IT and computer specialists, real estate professionals and brokers, business owners, aviation-related professions, attorneys and legal support, marketing and communications, reporters and writers, automotive mechanics, librarians, sales and retail personnel, students and law enforcement and federal security among several others. The types of organizations that employ these individuals (n= 1,225) were identified as companies (37%),

## *Demographic Summary*

- *A majority of respondents live and work in Broward*
- *Residents from the majority of cities in Broward County were represented*
- *Equal gender representation*
- *Majority were middle-age from diverse professions*
- *Residential occupancy is consistent with Broward distribution*
- *Homeownership is consistent with County average.*

government (32%), non-profit (13%), universities (8%), self-employed (4%), hospitals (2%), unemployed (1%), and other (3%).

Approximately a third of respondents described their neighborhood as suburban with houses, shops and business. An additional 25% of them described their neighborhood as a residential suburbia. Survey participants living in a primarily residential city accounted for 37%, and those living in a city with mixed-use of housing and businesses were the remaining 7%. The majority of participants (70%, n = 1367) indicated they owned their primary residence and the remaining (14%) were self-identified as renters.

***Traveling Behaviors*** According to the administered survey, traveling without a car in Broward County is uncommon (32% n=1552) and more than a third of residents envision never, in their current living and working conditions, would they be able to travel to nearby destinations without a car (37%, n=612). The explanations for being unable to travel to nearby destinations without a car and barriers to active commuting were categorized as either infrastructure, transit, distance, safety, ability, and/or environment.

***Infrastructure*** Approximately 15% (n=612) claimed they would not travel without a car

*"I can travel one direction as there are sidewalks but not the other direction, which is where a lot of dining areas are located and I would like to walk."*

due to a lack of sidewalks, bike lanes, walking and bike paths that would assist in making active commuting to and from nearby destinations possible and pleasant. A larger number of respondents (n=1,485) was split with approximately half feeling there was too little and the other half feeling there was the right amount of sidewalks in Broward County. A quarter of respondents

(26%, n=403) reported that they do currently travel as pedestrians when not using a car.

According to Jim Sallis et. al., access to sidewalks is the most important built environment factor related to physical activity. Therefore, an absence or disconnect in sidewalk grids would likely result in a community with lower physical activity averages and higher rates of chronic disease over time. Neighborhoods with sidewalks are considered more walkable and pedestrian-friendly. Urban Land Institute research confirmed, home buyers are willing to pay more for homes in walkable neighborhoods, and an analysis by Real Estate Research Corp. demonstrated that property values rise fastest in pedestrian-friendly areas.

The presence of bike lanes and paths has been previously positive impacts on the average level of physical activity. Approximately a tenth of respondents (11%, n=1552) travel by bike when they are not traveling by car, but 30% (n=1609) of respondents would travel more without a car if bike lanes were better maintained and 40% (n=1609) would travel if there were more bike lanes on the roads or wide paved shoulders with white lines were provided. More than half (54%, n=1487) of the respondents stated there were too few places to bike in Broward. These numbers are in line with the rest of the country. According to a National Survey of Bicyclist and Pedestrian Attitudes and Behavior in 2008 by the National Highway Traffic Safety Administration, 47% of Americans 16 and older say they would like to see more bike paths, lanes, and trails in their community (Bikesbelong.org).

In addition, bike facilities, such as covered bike parking, provided at the destinations was reported as an influencing factor in the decision to travel without a car by a third of participants (n=531). If worksites had locker rooms with showers, 15% of respondents would consider actively commuting to work rather than traveling with a car. Currently, 37% (n=1,487) of respondents travel only two to five miles to work, which could be a comfortable bicycle ride if amenities, facilities, and a comfortable and safe route was provided. The majority (65%, n=550) of trips made for recreation purposes were between one and five miles, which depending on the walking, biking, and transit network could be comfortably made by actively commuting for the average adult.

The parks, playgrounds, and recreation sites were noted as a Broward County asset in encouraging physical activity. The majority of residents stated there was the right amount of these types of facilities, (64%, n=1500). Accessing these facilities in an active form (without a car) would drastically increase if shaded infrastructure in the form of trees or canopies were established.

Safety Approximately half of the participants stated they would travel more often without a car if they felt safe doing so, and 10% stated they would only consider traveling with a car because of safety reasons. Traffic was mentioned as the main safety concern accompanied by crime, loose dogs, drug users, and the presence of homeless persons on park and transit benches.

Ability A pronounced proportion of respondents stated that they would walk more if sidewalks were accessible for persons with disabilities. Several respondents mentioned their

age as a deterrent to actively commuting the distance to reach a destination. Although the majority of seniors do not work or attend school, many do purchase food from grocery stores. The distance to a local grocery store was less than one-mile for 44% (n=668) of respondents. With safe crossings, assisted carts to carry items, shade, and secure walking paths, many elders would be enabled to access food, increase their incidental physical activity, improve their mental health, increase their social capital with these elements facilitating the concept of aging in place.

Transit A fifth of respondents (20.8% n=612) who reported traveling solely by car stated their main barrier was associated with mass transit limitations. Approximately a third of these respondents (n=207) provided a comment in regards to transit in their community. The comments were categorized and can be found in Table (A). Overall half of the respondents (48%, n=1491) felt there was not enough public transportation within walking distance, while 38% felt there was just the right amount and 14% did not know (Figure 2). Individuals who felt they could not travel to nearby destinations without a car were over three times more likely (OR=3.59; p<.000) to drive because they felt public transport was insufficient or they felt the distance was long. Respondents who identified themselves as living outside of the city were also over three times more likely (OR=3.5) to drive due to lack of public transportation access and distance.

*"Limited access to other modes of transportation"*  
*Resident from 33076*

**Table A - Transit Related Barriers to Getting Around without a Car**

Barriers Listed by Broward Residents	Number of Responses
<b>Limited/Lack of Public Transportation</b>	<b>72</b>
<b>Public Transportation is Inconvenient, Too Far, Takes too Long</b>	<b>65</b>
No Public Transportation Close By	26
Inconvenient/Inefficient/Unreliable Transit System	15
Poor Infrastructure & Unsafe/Dangerous Roads	13
Stores spread out/ Far Away	6
<b>Other</b>	<b>10</b>
<b>Total (n)</b>	<b>207</b>

**Figure 2: Amount of Public Transportation Within Walking Distance**

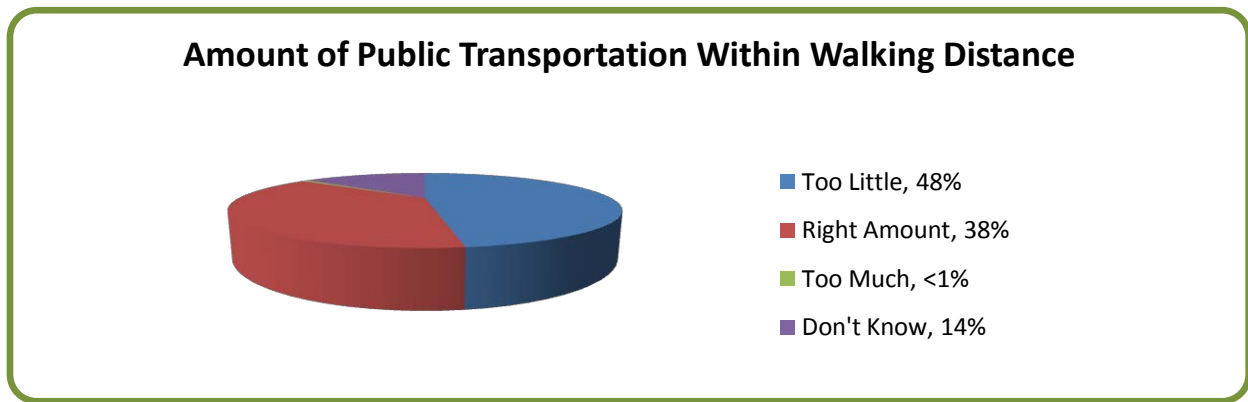

Mix-Use A 2003 article in the *American Journal of Public Health* showed that mental health and well-being is related to social capital. Individuals residing in walkable, pedestrian-friendly neighborhoods know their neighbors, participate politically, trust others, and are socially engaged (Leyden, 2003). More than half of the participants (54%, n=1491), felt there were too few stores and restaurants within an easy walk of their house. More than a third of individuals stated distance to destinations was the reason why they would choose to only travel by car. Half of the respondents (49% n=1609) in their current condition, would travel more often without a car if there were destinations within walking and biking distance. Among the third of respondents who characterized their community as mixed-use, 66% of respondents said they could travel to nearby destinations without a car. Individuals who identified most trips being a mile or less from their home were twice as likely (OR=2.17) to report no issue with public transportation or distances (p=.002). Based on the data increased mixed-land use partnered with Smart Growth principals has the potential to increase physical activity levels, bolster social capital and interaction , improve well-being and prevent chronic diseases for the residents of Broward County.

Housing Reported amount of low income, middle income, or high income housing in respondent neighborhoods determined whether participants felt inclined to select biking or walking over driving. When comparing means between groups individuals in low income and middle income neighborhoods demonstrated a positive association with taking half or more trips by car (p=.02) and (p=.004), respectively. Similarly respondents in high income neighborhoods demonstrated a positive association with reported ability to travel to most

destinations without a car ( $p=.03$ ). Participants who reported living in high income neighborhoods had a higher odds of reporting having parks and playgrounds within walking distance ( $OR=1.5$ ), places within walking distance ( $OR=1.68$ ), places to bike ( $OR=1.94$ ), new store and office developments ( $OR=2.46$ ), new housing development ( $OR=2.80$ ), and warehouse store development ( $2.12$ ) with each demonstrating the same significant association ( $p<.000$ ).

### **3-Foot Passing Law**

There is a three-foot minimum distance for a motorist passing a bicyclist required by Florida State Law. A listserv registered with the Florida Department of Transportation (FDOT), Office of Commuter Services, received the aforementioned survey with an additional statement, *I am aware of the 3-foot minimum passing distance required for a motorist passing a bicyclist*. A total of 463 respondents responded true (289, 62%) or false (174, 38%), which is depicted in Figure 3. The majority responded 'true' as a testament to the effectiveness of FDOT Commuter Services' social marketing campaign to increase the awareness of the 3-foot passing law.

**Figure 3: Awareness of FL 3-Foot Passing Law**

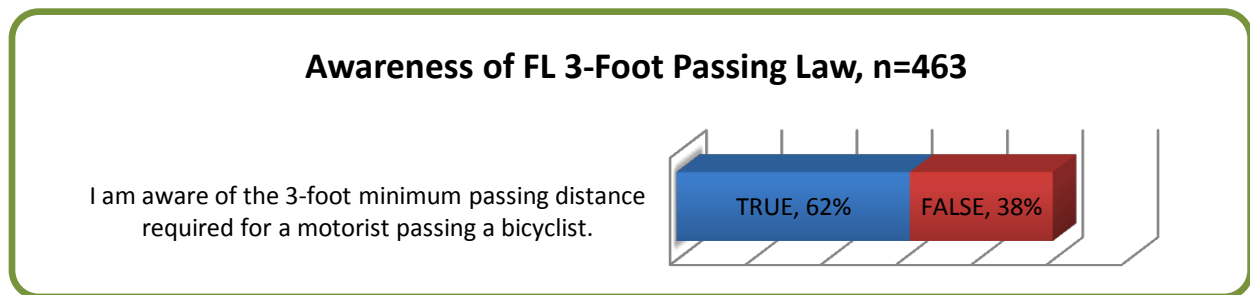

### **Smart Growth**

According to the Smart Growth Partnership website, Smart Growth is a comprehensive approach to development used in many cities across the nation which (1) encourages development in existing urbanized areas, (2) creates more compact development in non-urbanized areas, (3) promotes the proximity of jobs, shopping, and services to residential areas, (4) provides more transportation options, (5) and ensures access to natural areas

(<http://www.smartgrowthpartnership.org/defining-smart-growth.html>). Two-thirds of survey respondents were not familiar with the term Smart Growth (Figure 4). In a text analysis of the 431 responses, the vast majority of respondents (93%) were right on target or mentioned at least one Smart Growth principal in a description of what the term meant to them. Less than 5% (n=19) of respondents were 'off' on their definition of smart growth with responses such as, growth that takes into account population trends and environmental aspects, planning, development that positively impacts everyday life, planned community living including healthy options. Few responses (2%, n=7) were categorized as 'wrong' with responses such as, to gain knowledge. Only one person described smart growth in a negative connotation as 'intrusive zoning'. Respondents who were familiar with Smart Growth were twice as likely (OR=2.69) to prefer houses that were built closer together on smaller lots than those that were not familiar with the concept (p<.000).

**Figure 4: Familiarity with Smart Growth**

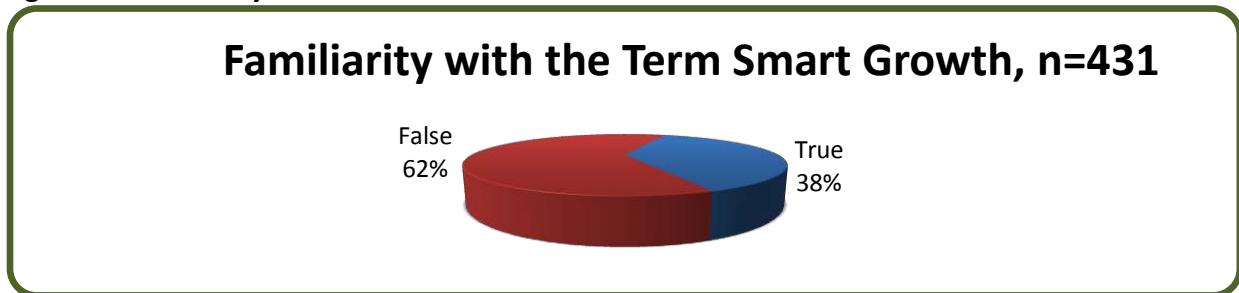

A 2003 study by Smart Growth America entitled *Measuring Health Effects of Sprawl: A National Analysis of Physical Activity, Obesity and Chronic Disease* calculated the expected impact of sprawl on the body mass index and weight of an average person (height- 5'7"). The results reveal that people in more sprawling counties are likely to have a higher body mass index (BMI), which is a standard measure of weight-to-height that is used to determine if people are overweight or obese. The study also found a direct relationship between sprawl and chronic disease. The odds of having hypertension, or high blood pressure, are six percent higher for every 50-point increase in the degree of sprawl. Table 2 highlights how Broward compares to the rest of Florida and other counties where there is less sprawl. A lower number indicates a higher degree of sprawl.

**Table 2: Sprawl and its Relation to Health**

Area	Sprawl Score	Expected Body Mass Index	Expected Weight
<b>Broward</b>	<b>127.01</b>	<b>26.01</b>	<b>166.05</b>
Miami-Dade County	136.17	25.98	166.85
Florida	108.77	26.07	166.45
New York County (Manhattan)	352.07	25.23	161.11

Source: *Smart Growth America* entitled *Measuring Health Effects of Sprawl: A National Analysis of Physical Activity, Obesity and Chronic Disease*, September 2003.

## CHAPTER IV: PUBLIC

### WORKSHOP SERIES The Public

Workshop series was held in three areas of Broward County to provide multiple and convenient opportunities for Broward residents to attend workshops, learn about Complete Streets, and provide input and feedback. In addition to the three workshops, two focus groups were held. The three public workshops were held in North Lauderdale (Northwest Broward), West Park (Southeast Broward), and Fort Lauderdale (Central Broward) and those who were in attendance were asked to complete a survey at the end of the presentation about Complete Streets and Smart Growth Policies. Large posters describing Complete Streets and their benefits were created for the workshops and attendees were encouraged to answer questions and provide feedback. Copies of these posters are available online at [www.BrowardCompleteStreets.org](http://www.BrowardCompleteStreets.org). The feedback received during the five events was extremely insightful and provided a broad view of community needs and opinions. Each location and community where the workshops took place as well as their feedback is described in this section.

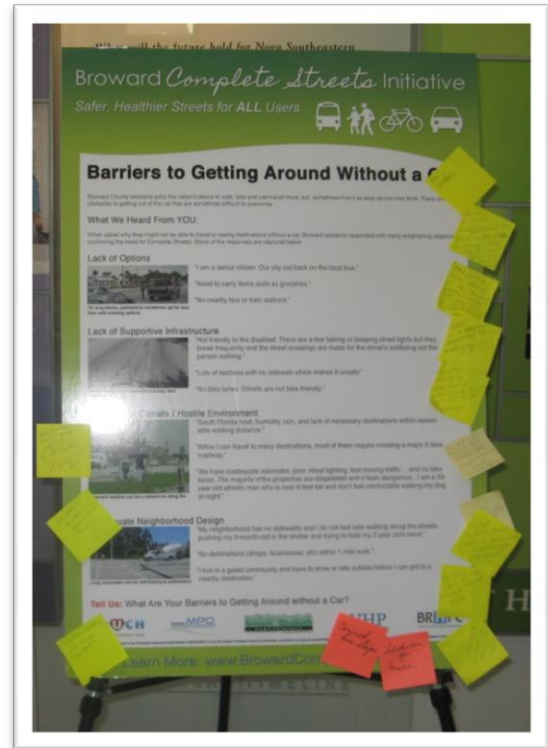

**City of North Lauderdale** The City of North Lauderdale is 2.2 square miles and was incorporated in 1963. The city was planned by Architect Morris Lapidus who also designed many of the famous hotels in Miami Beach. North Lauderdale is a young and diverse city. In 2000, it held the youngest median age for residents in Broward County (Broward MPO). In 2011, North Lauderdale was named one of the Top 100



Communities for Youth by American's Promise Alliance.

(<http://www.nlauderdale.org/document/index.php>).

According to the 2010 Census, the city has a population of 41,023. 28.9% of the population is under 18 years of age and 6.5% is over the age of 65. 25.8% of the population identify as Hispanic or Latino. The population by race is as follows: 33.1% White, 53.4% African American, 2.9% Asian, 0.3% American Indian and Alaska Native, 0% Native Hawaiian and Pacific Islander, 6.4% Other, and 3.8% Identified by two or more (<http://2010.census.gov>).

By 2014, the Broward MPO has projected travel time to work for most North Lauderdale residents to be between 15-29 (39%) and 30-59 (38%) minutes. The forecasted means of transportation for employed individuals in 2014 is 95% Car, Truck, or Van to work with the other 5% devoted to Public or Other Transportation or working at home (Broward MPO).

A total of 53 community members participated in the public workshop held on Tuesday, April 17 from 3:00-7:00PM at North Lauderdale City Complex: 701 SW 71<sup>st</sup> Ave., North Lauderdale, 33068.

**City of West Park** The City of West Park was incorporated in 2005. It is Broward's 31<sup>st</sup> city. Its neighborhoods include Miami Gardens, Carver Ranches, Lake Forest, and Utopia. In 2011, West Park received recognition as a Playful City USA for its efforts to increase play opportunities for children. Most of the city is residential but the city also includes business, commercial and industrial areas (<http://www.cityofwestpark.org/>).



According to the 2010 Census, the city has a population of 14,156. 27.1% of the population is under 18 years of age and 10.3% is over the age of 65. 28.9% of the population identify as Hispanic or Latino. The population by race is as follows: 32.8% White, 57.9% African American, 1.0% Asian, 0.4% American Indian and Alaska Native, 0% Native Hawaiian and Pacific Islander, 4.5% Other, and 3.3% Identified by two or more (<http://2010.census.gov>).

A total of 35 community members participated in the workshop held on April 18 from 6:00 to 8:00PM at Carver Ranches Library located at 4735 SW 18 St, West Park, 33023.

## ***Nova Southeastern University***

Nova Southeastern University is located in the City of Fort Lauderdale. The University has a student body of 27,518 and has 4,265 faculty and staff for a total of 31,758 individuals affiliated with the University (<http://collegestats.org/college/nova-southeastern-university>).

A total of 60 students and community members participated in the workshop on Thursday, April 19 from 12:00-3:00PM at NOVA Student Center: 3301 College Ave., Fort Lauderdale, 33314. The first hour 12:00-1:00PM targeted students during their weekly SEA (Student Events and Activities) Thursday event. The remainder of the event captured students passing by and community members who had joined us from various sectors.

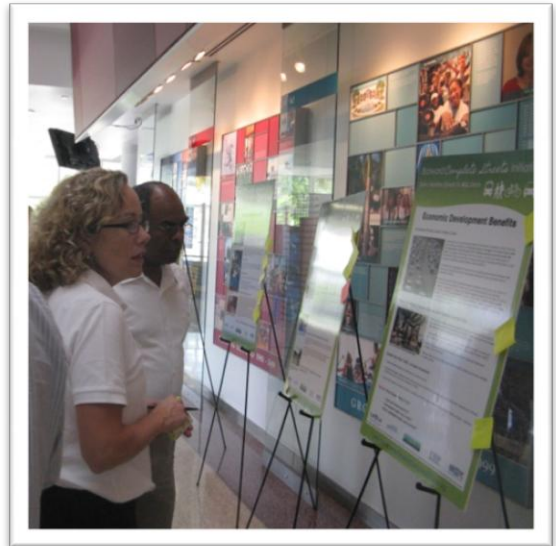

***Workshop Feedback*** During the three public workshops, boards were used to summarize the importance of Complete Streets. Volunteers stood next to each board and helped guide community members through the concepts highlighted them. Community Members were asked to provide feedback and share their own experience regarding barriers, such as getting around without a car. Their feedback was written on notes attached to the board to promote interaction and conversation. Participants indicated where they lived near a Complete Street (Table 1), if they felt their city was ready to implement complete streets (Table 2), what would make them walk, bike, or use public transportation more (Table 3), what the barriers were to getting around without a car (Table 4), what benefit of complete streets was most important to them (Table 5), and what elements of the Complete Streets vision were most important to them (Table 6). Notably, most participants said their communities were ready for Complete Streets, and additionally listed components of Complete Streets as things that would make them walk, bike, or use public transportation more. The barriers to getting around without a car listed by participants were similar to those listed by survey participants, including Limited/Lack of Public Transportation, Public Transportation is Inconvenient, Too Far, or Takes

too long. The most underscored potential benefit of Complete Streets was the creation of more walkable and livable communities, followed by an improved local economy.

**Figure 6. Do you live near a complete Street?**

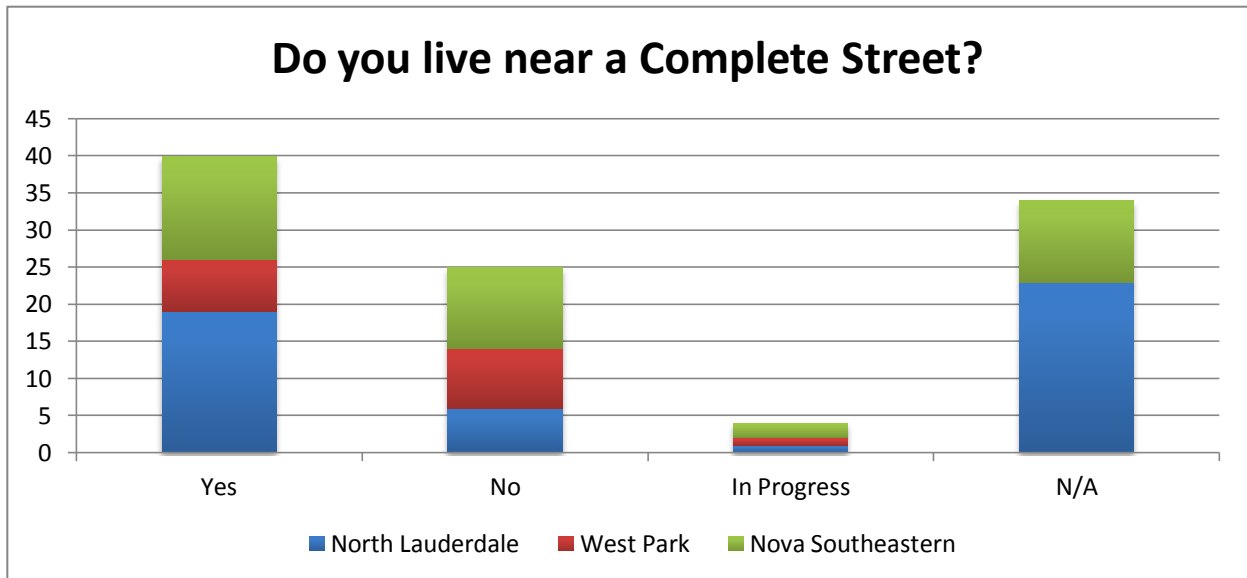

**Figure 7. Is your community Ready for Complete Streets?**

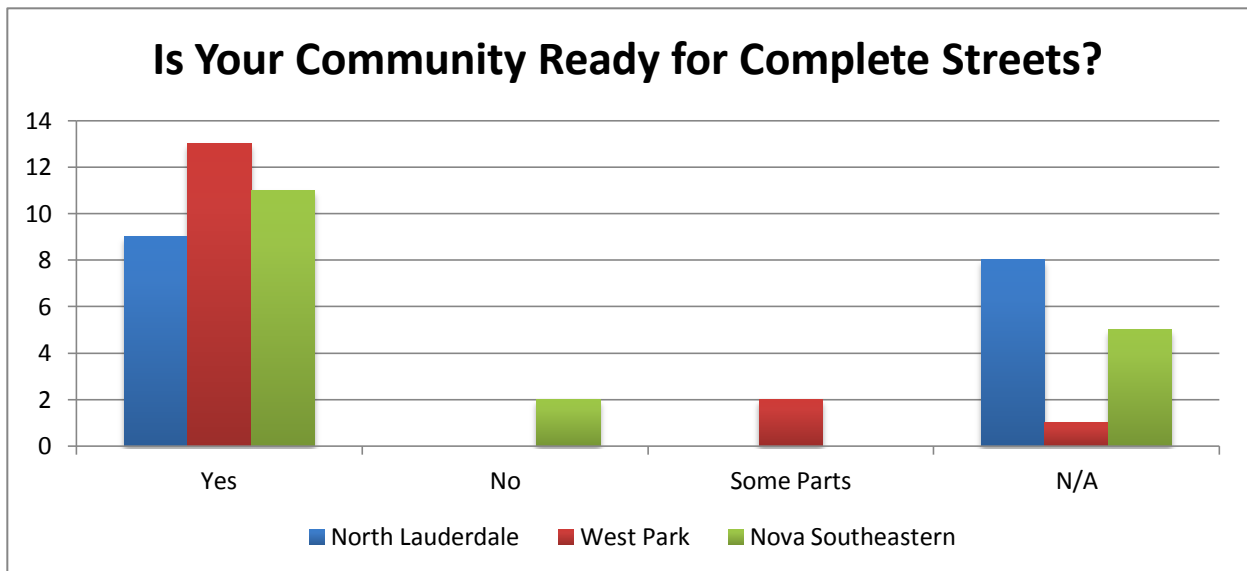

**Figure 8. What would make you walk, bike, or use public transportation more?**

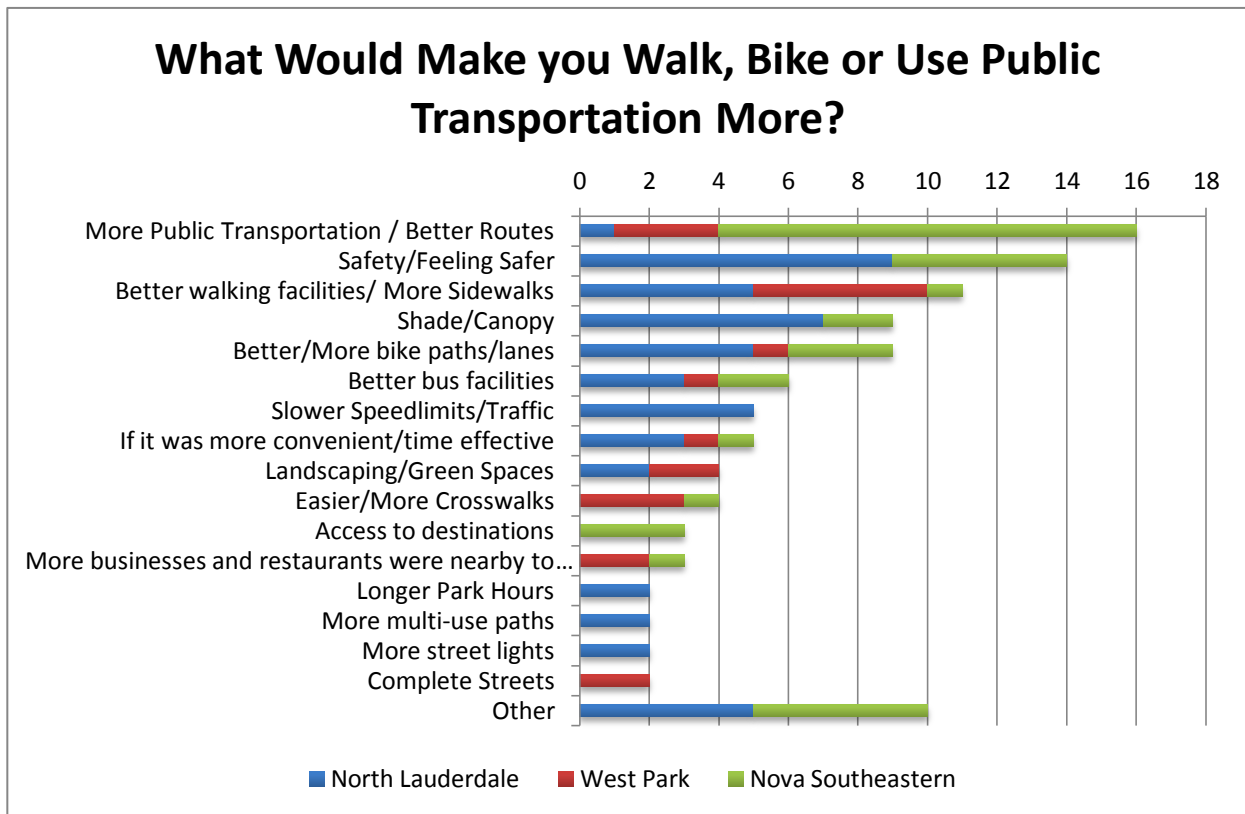

**Figure 9. What are the Barriers to getting around without a car?**

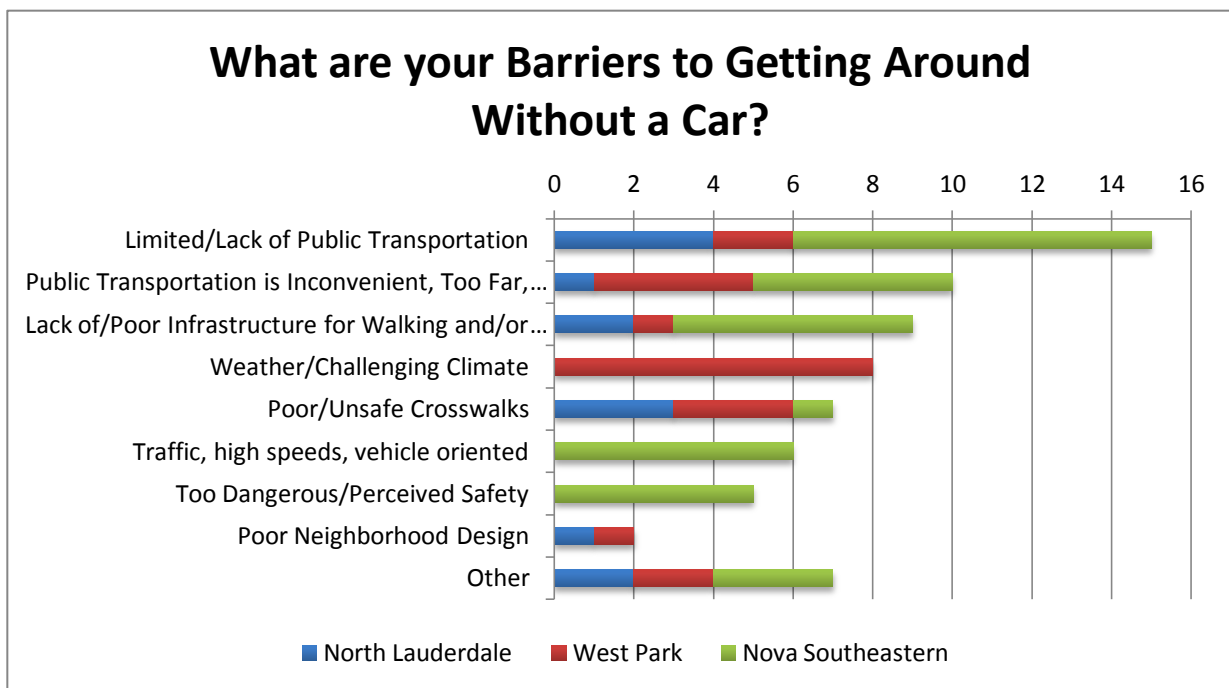

**Figure 10. What Benefit means most to you?**

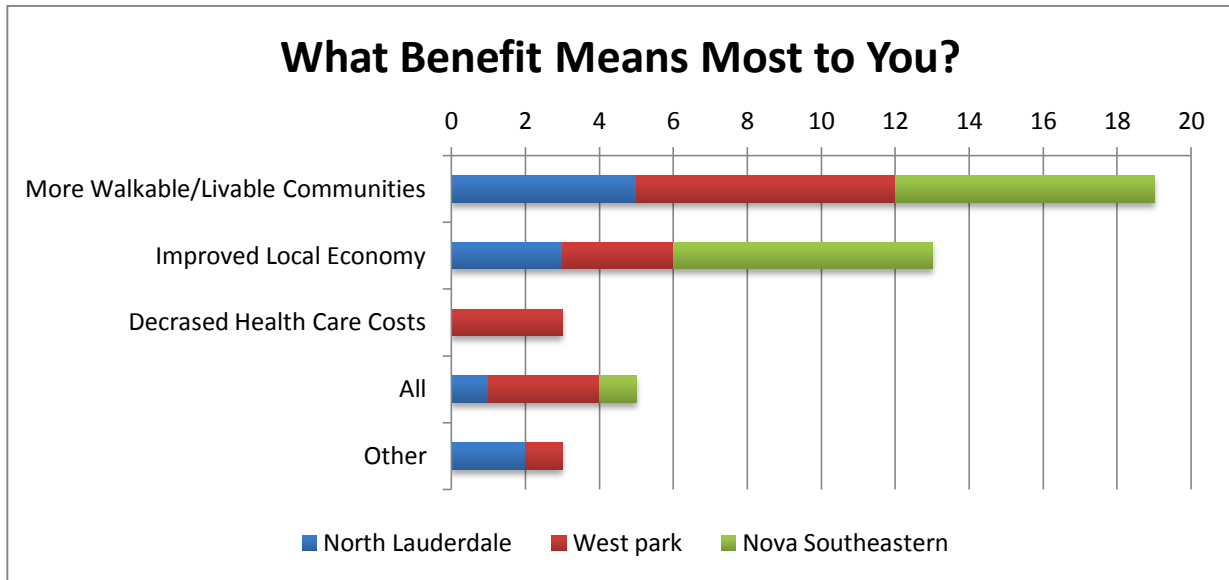

**Figure 11. What Vision Elements are Most Important to You?**

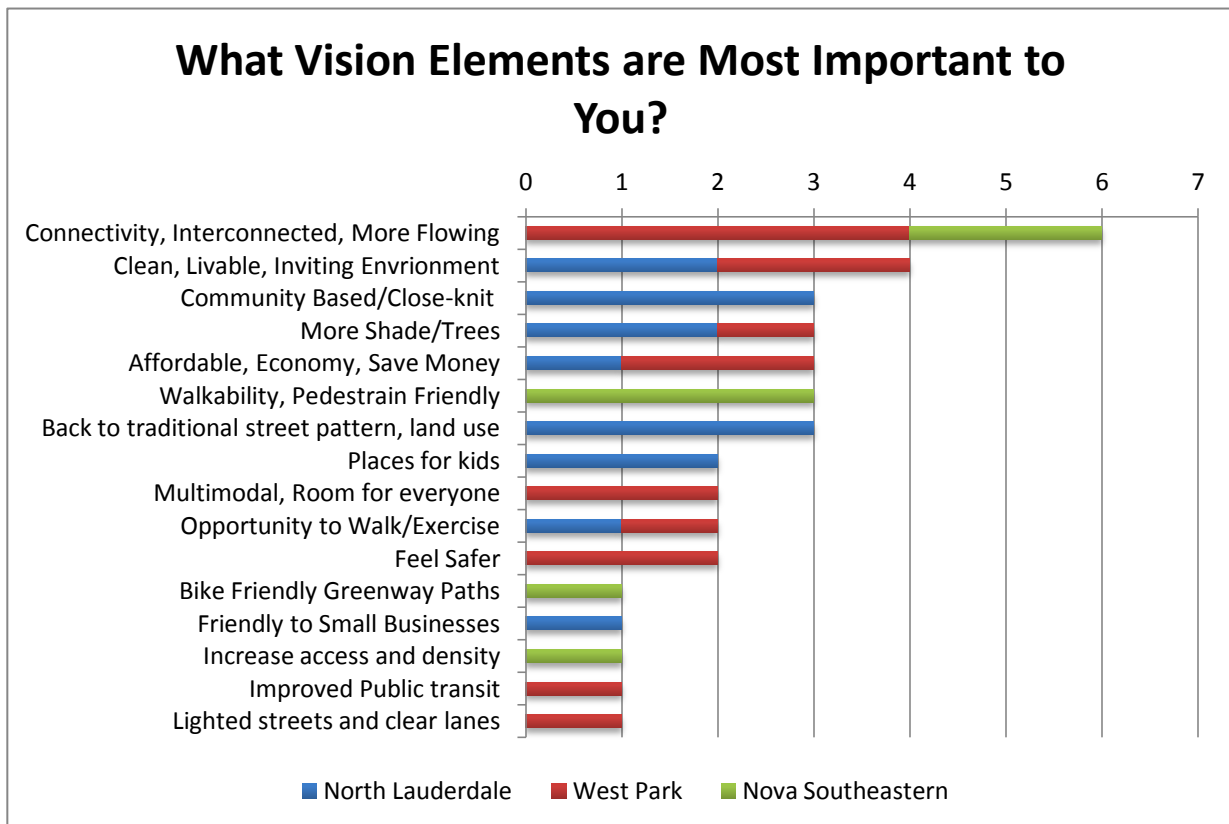

Participants were also asked how they saw themselves being involved in Complete Streets. Some of the responses included.

- Joining/Staying involved in the Technical Advisory Committee (TAC)

- Taking the Complete Streets survey
- More Public Workshops
- Educating the Public
- Build a Better block Grants
- And going to the website to educate themselves

Lastly, participants were asked about next steps; recurrently they suggested coordinating with involved agencies and posting the Complete Streets boards online - both of which have been accomplished since the workshops.

A feedback survey was additionally developed and administered to those who attended one of the three public workshops offered. There were 27 completed surveys from the North Lauderdale workshop, 22 from West Park and 6 from Fort Lauderdale, with a combined total of 55. The questions asked sought to determine whether or not the residents had any safety concerns or questions regarding the current state of the streets in Broward County, and also how receptive they would be to their community adopting the Complete Streets design standards and the Smart Growth Policies. Though the questions were specific, the survey allowed individuals to elaborate on their responses. Participants were able to provide their opinion of the workshop as well as make recommendations for future improvement.

Of the 55 survey respondents, 41 (74.5%), indicated that they had questions or concerns regarding the streets in Broward prior to this workshop while the remaining 14 (25.5%) stated they did not. 53 of the 55 participants (96.4%) responded that they would like to see Complete Streets in their community, 1 participant (1.8%) did not, and 1 participant gave no response. 53 of the 55 participants (96.4%) indicated that they would like to see Smart Growth policies adopted; the remaining 2 participants (3.6 %) failed to give a response. Participants stressed their concerns regarding the safety of pedestrians and cyclist due to a lack of sidewalks as well as bike lanes. A lack of reliable transportation was also a common concern. Respondents conveyed that they found the workshops to be enjoyable, educational and well-presented; however, they encouraged more advertising efforts in the future.

## CHAPTER V: PRESENTATIONS & FOCUS GROUP

**DISCUSSIONS** Two focus groups were held in Broward County. Each location, community and focus group feedback is described in this section.

***City of Deerfield Beach, Highland Garden Community*** The Highland Garden Community is a public housing development that caters to the elderly and disabled; Highland Garden is located in the City of Deerfield Beach.

According to the 2010 Census, the city has a population of 75,018. 18.0% of the population is under 18 years of age and 21.5% is over the age of 65. 14.2% of the population identify as Hispanic or Latino. The population by race is as follows: 65.7% White, 25.6% African American, 1.5% Asian, 0.2% American Indian and Alaska Native, 0% Native Hawaiian and Pacific Islander, 4.1% Other, and 2.7% Identified by two or more (<http://2010.census.gov>).

By 2014, the Broward MPO has projected travel time to work for most Deerfield Beach residents to be either Less than 15 minutes (20%), between 15-29 (43%) or 30-59 (29%) minutes. The forecasted means of transportation for employed individuals in 2014 is 94% Car, Truck, or Van to work with the other 6% devoted to Public or Other Transportation or working at home (Broward MPO).

At Highland Gardens, Urban Health Partnerships heard frustration from individuals who feel isolated in an environment that has little mixed-use development within walking distance and just recently lost a major bus route. It was clear that the desire to walk more exists in this community; however, this group faced many challenges. Some individuals were limited by obesity/disability physically had challenges, others had fears based on previous experiences and most found restrictions on public transportation service extremely confining/limiting—only one resident in attendance owned a car. Complete Streets comprehensively addresses all of these concerns and makes a walkable, livable community attainable. This data emphasizes how



Broward has great potential to expand their world through incremental improvements to the right of way and could become a leading model for positive mixed-use urban environments.

### ***City of West Park, Carver Ranches Public Library After School***

#### ***Program*** The second focus group at

Carver Ranches library involved elementary students ranging from first through six grade, and proved to be a much more complex challenge. The children showed a great interest in Complete Streets, however because of the crime they witness on a daily basis, their definition of “safe” involved public safety improvements that are not a



direct focus of Complete Streets. UHP, SGP and the MPO believe that by providing more opportunities to walk and bike, Complete Streets would provide more “eyes on the street” and in effect improve the safety of the neighborhood.

## CHAPTER VI: MEDIA REPORT & PUBLIC DISCOURSE

***Broward Complete Streets Micro-site Report*** The Broward Complete Streets site, available at [www.BrowardCompleteStreets.org](http://www.BrowardCompleteStreets.org) was created as a micro-site of the UHP website. This site had contained all relevant information for the initiative including links to complete the survey and information about the public workshops. Since January 2012, the UHP site has received over 5,500 page-views with over 1,128 unique visitors. Of these visits, the most popular page visited was the Complete Streets homepage with 1,143 views. The Survey, *Get Involved*, *Technical Advisory Committee* pages were also popular with 368, 219, and 185 page-views, respectively. The city with the most unique visitor page-views was Ft. Lauderdale followed by Miami Beach, Miami, Hialeah, Orlando, Pembroke Pines, Pompano Beach, Lakeland, and Hollywood, Florida, with the majority of these cities falling within Broward County lines. This micro-site continues to garner traffic as more individuals in Broward County learn about the Complete Streets Initiative. A Final Complete Streets Guidelines resource will be made available on the site in June 2012 for public use.

# CHAPTER VII: SUMMARY OF KEY FINDINGS & RECOMMENDED STRATEGIES

## *Summary of Key Findings*

- The majority of Broward residents currently travel with a car due to limitations in alternate forms of transportation. They would like to see these efforts expanded to include more sidewalks, public transit near their homes, bike lanes with painted white lines, more destinations within walking or biking distance, and a sense of safety while commuting without a car.
- There are not enough places to bike or public transportation options within an easy walk for Broward Residents. If alternatives were provided, 90% of respondents would consider traveling without a car.
- Lack of mass transit options was the greatest barrier for adults to get around without a car followed by personal safety concerns. Among children who regularly walk to and from school and neighboring facilities, safety was their biggest concern.
- Broward County's parks, playgrounds, and recreation sites were identified as assets to encouraging physical activity. The majority of respondents stated there were the right amount of parks and playgrounds (64%) and places to walk to for fun (54%). Accessing these facilities without a car would drastically increase if shaded infrastructure in forms of trees or canopies were provided.
- Half of all respondents felt there were too few stores within comfortable walking or bicycling distance from their homes. Physical ability and age were noted as major deterrents to actively commuting to destinations. Older adults living in Broward developments felt isolated due to the lack of opportunity to conveniently access daily activities by foot. These adults also felt limited in daily activities due to sparse mass transit options.
- Individuals living in low or middle income neighborhoods were more likely to feel the need to travel with a car to nearby destinations compared to those living in high income neighborhoods due to environmental barriers and safety. Those living in high-income neighborhoods were more likely to have amenities within walking distance.

- The majority of respondents were aware of the law requiring a three-foot minimum distance for motorist passing a bicyclist.
- Although approximately two-thirds of respondents were not familiar with the term Smart Growth, the vast majority described the term correctly. This suggests that these principles are inherently logical to creating a healthy urban environment yet remain absent from developing urban areas.
- Three quarters of participants in the public process indicated they had concerns regarding the streets in Broward prior to engaging in the workshop. The majority of Broward residents felt their community was ready for Complete Streets implementation, this greatly contrasts with the less than 1% who claimed to live near at least one complete street in Broward County. Complete Streets to most respondents promised the opportunity for more walkable and livable communities. Participants envisioned a better interconnected community with high social capital as a result of a commitment to developing local Complete Streets. An overwhelming proportion (96.4%) of participants indicated they would like to see Complete Streets policies adopted and implemented in their respective communities.

***Recommended Strategies*** The findings from the survey and other community engagement activities revealed a clear direction for recommended strategies. This list was compiled to guide community members and community partners in the implementation of Complete Streets. These strategies are outlined and described in this section.

### ***Strategy 1: Enhance Quality of Life by Implementing Complete Streets***

Transportation systems impact nearly every aspect of an individuals' life including the physical environment, the economy, safety and most importantly the quality. One of the foundational goals of Complete Streets is to establish a multi-modal transportation system offering pedestrian walkways, bike paths, improved and expanded public transportation options as well as improvements to existing structures such as shading, lights, and an expanded network of current options. In building upon current systems communities have an increased opportunity for social interaction, the potential to positively impact both mental and physical well-being and

to greatly improve overall quality of life. Through this process it is important to quantify and evaluate the actual outcomes and impacts of the project. Research and assessments are ideal ways to track the influence of Complete Streets; by quantitatively and qualitatively measuring outcomes then sharing results with community members stakeholders are provided the tools to monitor impact and outcomes. This is recommended for each step of the process including planning, monitoring and evaluation.

Funding studies that incorporate health considerations prior to project implementation helps to tailor the Complete Streets model to holistically fit the respective community. The recommended research tool for this is the Health Impact Assessment, which comprehensively examines all potential outcomes that may result from a project and provides an excellent foundation for communities to proceed with planning confidently. The CDC explains, “HIA is a process that helps evaluate the potential health effects of a plan, project or policy before it is built or implemented. An HIA can provide recommendations to increase positive health outcomes and minimize adverse health outcomes. HIA brings potential public health impacts and considerations to the decision-making process for plans, projects, and policies that fall outside the traditional public health arenas, such as transportation and land use.” An HIA can help anticipate both costs and benefits of Complete Streets plans on the community and can aid in the decision-making process. More information on HIA’s is available at <http://www.cdc.gov/healthyplaces/hia.htm>. The initial investment in HIA research enables communities to maximize on positive health outcomes and modify Complete Streets design, if necessary, to specific community needs.

In conjunction, a strong monitoring and evaluation plan should be developed to include a Community Needs Assessment to measure the process, outcome and impact of change via at a collection and analysis, with a Management Information Systems as a tool to collect and store data during and after the implementation of Complete Streets. This information can reveal any areas needing improvement, highlight real mental and physical health impacts and outcomes, measure sustainability and improved quality of life and inform planning for future Complete Streets projects Further, these assessments can guide future direction for funding Complete Streets projects and can establish Complete Streets as a successful evidence-based model for expanding multi-modal transportation.

## ***Strategy 2: Complement Complete Streets design with Smart Growth Principles***

Smart Growth principles can be used as a template to expand transportation options, promote regional and community collaboration, strengthen existing community features, expand upon community design that supports multi-modal transportation and further explore the transportation needs of elders by considering aging in place strategies for Broward County residents. Smart Growth emphasizes essential factors necessary to making a community livable for its residents. Its policies address items related to walkability, bikability, on-street parking, landscaping, sidewalks, retail placement and amenities, and providing a range of housing opportunities. Smart Growth promotes an environment in which community members have a “24-hour place to live, shop, and work” in a mixed-land use environment serviced by a variety of transportation options. It seeks to establish a strong sense of ‘place’ with distinct buildings, neighborhoods and communities. To grow these communities based on Smart Growth principles requires regional and community stakeholders to assume interactive and collaborative roles in leading development and neighborhood and community design. More information and resources on Smart Growth are available through the Smart Growth Partnership at <http://www.smartgrowthpartnership.org/>.

Smart Growth principles are very much aligned with Complete Streets goals. During surveys and workshops many community aspects that are components of Smart Growth design were the items to which respondents expressed a need for change. The surveys and workshops revealed a strong desire among individuals to lead active lifestyles, with the need for places to access within a feasible distance left greatly unmet among almost every community. Utilizing Smart Growth as a complement to Complete Streets provides the tools to bridge this gap of motivation to enjoy an active, healthful lifestyle and the creation of an environment built encourages one.

## ***Strategy 3: Advocate for the Expansion of Multimodal Transportation***

Based on the Broward residents' needs that are clearly delineated through this Community Engagement Report, organizational support at a County and municipal level is subsequently vital for prioritizing goals and protocols. The organizational components to

be considered include incorporation of supportive policies, assessment of funding allocation, community involvement in public projects and educating Broward decision makers and residents about Complete Streets. Transportation funding for projects related to Complete Streets can be advantageous to community design and livability.

Community members expressed a need for more bus stops and public transportation provisions, bicycle and pedestrian facilities, and connections such as sidewalks and paths. With the majority of individuals reiterating these as primary community needs, budgets for roadway costs should entice a balanced funding approach to address the needs of all commuters. Community members can request this funding to actualize complete streets and an environment that incites an active, interactive lifestyle. As urban development moves forward, alternate forms of transportation must be advocated for, explored and expanded as excessive automobile use has been reported to be expensive, isolating, and impractical at times.

The partners who have prepared this report are working towards guidelines and policies that will balance the modes of transportation and provide opportunities to shift from the automobile-dependent norm to a safe and active transit system that adequately serves its patrons.

***Strategy 4: Address the Needs of Older Adults*** South Florida is home to a large elderly population with a growing percentage of individuals going into retirement age. The majority of individuals aspire to age in their current communities independently, but access to daily needs while faced with the limitations of ageing such as disabilities, sensitivity to sun light, etc may prohibit them from realizing this desire. Considering this is a growing demographic in Broward, it is imperative that their needs be assessed and met when developing Complete Streets policies and projects. The implementation of Complete Streets should promote aging in place and instigate the removal of many isolation factors and barriers faced by the retirement community. While incorporation of universal design standards in Complete Streets can assist with creating age-friendly communities and facilities that support aging in place, input from communities is essential in meeting the needs of this specific subgroup.

A community engagement process to consider is outlined in the Safe Routes to Age in Place model. This program engages elderly community members and stakeholders to identify their travel patterns, needs and concerns then communicates these findings to community leaders. The project then collaborates with leaders to develop protocols based on this information. By creating an informal forum setting, any individuals wishing to express a desire or concern are able to do so with this aggregate information being directly presented to the individuals responsible for community development with actions being informed directly by the community. Because this demographic represents such a large percentage of the total population, while developing Complete Streets plans it will be essential to incorporate similar forums and protocol development to ensure an inclusive development process with an end result of serving an entire population rather than only specific age demographics.

### ***Strategy 5: Incorporate and Expand Programs and Policies***

***Focused on Youth*** As discussed in the focus groups section, many individuals voiced a need to feel safe and secure while using other modes of transportation. In recent years there has been an increasing focus in public health on expanding multi-modal transportation, including pedestrian safety, at local, national and international levels supported by both nonprofits specializing in transportation issues and larger organizations such as the World Health Organization. Designing safe pedestrian and transportation methods for youth is one of the unifying themes in this programming. Safe Routes to School (SRTS) programs are an excellent example which have been applied locally and are nationally successful. These are sustained by community members, organizations, and local governments to improve the health and well being of children by enabling and encouraging them to walk and bicycle safely to school. The establishment of Safe Routes using the 5-E approach – Education, Engineering, Enforcement, Encouragement and Evaluation is recommended for fostering and securing this safe commute for youth. Implementing a comprehensive SRTS or similar program to shift cultural norms would inspire increased funding allocated to infrastructure that supports active commuting. This can be an important strategy and component for implementing Complete Streets in a community and should be considered for Broward County. This will not only support a safer environment but instill a sense of need for Complete Streets from a young age.

Locally non-infrastructure models have been successful as exemplified in Miami-Dade County with the University of Miami Miller School of Medicine's Walksafe™ and BikeSafe™ Programs; more information is available at [www.walksafe.us](http://www.walksafe.us) and [www.ibikesafe.us](http://www.ibikesafe.us). Both of these programs establish safe walking and biking routes to school and teach children from an early age the importance of an active lifestyle. Other similar practices suggested in the Safe Routes to School programs include walking school buses lead by parents and using existing parent groups (i.e. Parent Teacher Associations (PTA's)) to organize safe route plans. More information on Safe Routes to School is available at <http://www.saferoutesinfo.org/>.

Miami-Dade Metropolitan Planning Organization has funded SRTS planning studies that guide the prioritization of implementing SRTS infrastructure projects. Collaborative SRTS community efforts between infrastructure and non-infrastructure partners have achieved implementing Complete Streets principals along routes that connect students to their schools. By reaching the youth, behavioral change can occur at a much earlier age and become the new cultural norm in a secure healthy environment.

### ***Strategy 6: Utilize Social Marketing to Shift Cultural Norm***

While a desire for Complete Streets was almost unanimously expressed among those reached in this process, behavioral change is challenging to inspire. Although some individuals will adopt usage as a part of their lifestyle immediately after learning the benefits, others will need to be exposed multiple times, and further still some will need to be convinced that having access to Complete Streets will positively impact them. This represents the general pattern of a societal shift in cultural norm, therefore, measures must be taken for repeated exposure to Complete Streets to establish familiarity and underscore benefits. Social marketing can be an effective tool in reaching a community to encourage this behavioral modification. Campaigns aimed at shifting cultural norms towards positive alternate transit perceptions would promote Complete Streets, active transport, and physical activity. The Centers for Disease Control and Prevention (CDC) explains that using social media tools has become an effective way to expand reach, foster engagement and increase access to credible, science-based health messages. Social media and other emerging communication technologies can connect millions of voices to: (1) Increase the timely dissemination and potential impact of health and safety information,

(2) Leverage audience networks to facilitate information-sharing, (3) Expand reach to include broader, more diverse audiences, (4) Personalize and reinforce health messages that can be more easily tailored or targeted to particular audiences, (5) Facilitate interactive communication, connection and public engagement, and (6) Empower people to make safer and healthier decisions. More information and resources and strategies for social media marketing are outlined in the Center for Disease Control's *Health Communicator's Social Media Toolkit* available at: [www.cdc.gov/socialmedia/Tools/guidelines/pdf/SocialMediaToolkit\\_BM.pdf](http://www.cdc.gov/socialmedia/Tools/guidelines/pdf/SocialMediaToolkit_BM.pdf). By highlighting the benefits of Complete Streets through mass media broadcasting awareness and support can be bolstered within the community and affect an actual positive shift in cultural behavior.

### ***Strategy 7: Educate Policy-Makers, Engage Stakeholders and Establish Coalitions***

There exist three main groups necessary to strategizing a comprehensive approach for the development of Complete Streets: (1) Policy/Decision-makers, (2) Community Stakeholders and Coalitions, and (3) Residents and Advocates. It is important to partner with community decision-makers including organizations, businesses, and individuals - through outlining community needs as well as educating this group about the impact Complete Streets can have on their community in activity, wellness and local economy they can understand the importance of their role in implementation. This collective group can act in a grassroots approach to develop, establish and promote Complete Streets if they are well-informed about the positive outcomes of a shift in community planning and, subsequently, lifestyle. Policy-makers can work to compliment this effort by creating structure for any forthcoming project; further, they have multiple outlets through which they can communicate and promote the use of Complete Streets.

To maintain momentum and implementation of Complete Streets in a community, coalitions, technical advisory committees and advocacy groups should be established in support of neighborhood Complete Streets. Coalitions can involve public health and safety advocates as well as other interest groups that may benefit from Complete Streets policies and development. Many community members expressed interest in becoming involved in an organized group of individuals or organization where they can provide feedback and help create

events to promote Complete Streets. This can serve as an excellent tool for a community in improving complete streets as the necessity arises to ensure they remain current. Coalitions can help create political and community-based support for Complete Streets projects to sustain long-term commitment and positive health outcomes. Further, community organizations can sponsor community events that promote Complete Streets and inclusive community design. By involving community-based organizations and stakeholders in the planning process these can both assist in providing a complete view of the needs of a specific neighborhood and then organize and outline appropriate protocol.

Finally, community residents play a foundational role in establishing the precedent for change. They are intimately familiar with the strengths and weaknesses of their communities. Photovoice is a strategy that can be used to promote participation of community residents into the research and implementation process of Complete Streets. Photovoice is a technique where individuals can “identify, represent and enhance their community” through photographs. Community members are given cameras and asked to record their perspective as well as potentially help to catalyze change. Photovoice is a flexible technique and encourages community members to record and reflect on their community’s strengths and weaknesses, promote a dialogue about these and also provide a way to reach policy-makers regarding the issues (Wang, 1997). Photovoice may be an ideal format for Complete Streets because Complete Streets deals with the physical environment, something that can be photographed easily by community members and will show stakeholders the views and needs of those taking the photographs. Community members can be encouraged to show their pictures and describe why they chose the picture and how it affects them physically and socially. It also empowers the community to be involved in the effort and to voice their needs as a part of a needs assessment. These inputs are vital to understanding where and why Complete Streets are envisioned and important to the community.

## Appendix A: TECHNICAL ADVISORY COMMITTEE MEMBERS

Urban Health Partnerships facilitated the recruitment, communication, and engagement of the Metropolitan Planning Organization's Technical Advisory Committee (TAC) for the Broward Complete Streets Initiative. The members referenced below committed to serving for the duration of the project's first phase February - September 2012. The TAC brought expertise and representation from urban and regional planners, public health professionals, educators, engineers, researchers, transit and transportation departments, city officials and government staff, bicycle and pedestrian coordinators, smart growth and sustainability partners, urban designers, and not-for profits, among other areas.



### *Technical Advisory Committee Members*

**Alena Alberani**, Sustainable Community Partners  
**Scott Brunner**, Broward County Traffic Engineering  
**Paul Carpenter**, City of Coral Springs  
**Aylin Costa**, Broward County Highway Construction and Engineering  
**Andi Crawford**, Broward YMCA  
Bill Cross, South Florida Regional Transportation Authority  
**Heslop Daley**, City of Fort Lauderdale  
Arlene Davis, City of Port Everglades  
**Eric Dumbaugh**, Florida Atlantic University  
**Ellen Feiler**, Broward County Department of Health  
**Maribel Feliciano**, Broward County Air Quality  
**Jerry Ferguson**, City of Deerfield Beach  
**Pattie Gertenbach**, Broward Bicycle/Pedestrian Advisory Committee  
**Carolina Gutierrez**, University of Miami- Miller School of Medicine  
**Lori Hall**, City of Miramar  
**Ronald Kareiva**, FDOT  
**Gloria Katz**, Smart Growth Partnerships  
**Lynn Kunins**, Florida Introduces Physical Activity and Nutrition to Youth (FLIPANY)

**Rick Labinsky**, Hallandale Beach  
**Michael Madfis**, Community Involvement Roundtable/Smart Growth Partnership  
**Amanda Martinez**, City of Deerfield Beach  
**John-Mark Palacios**, FDOT Office of Modal Development  
**Teina Phillips**, Broward Regional Health Planning Council  
**John Ramos**, Broward County Transit  
**Joy Riddell**, AARP  
**Jonathan Roberson**, Broward County Transit  
**John Rude**, Broward Urban River Trails  
**Peter Schwarz**, Broward County Planning Council  
**Richard Tornese**, Broward County Highway Construction and Engineering  
**Kevin Walford**, City of Fort Lauderdale  
**Ben Ziskal**, City of Margate

#### *Staff:*

**Priscila Clawges**, Broward MPO  
**Anamarie Garces**, Urban Health Partnerships  
**Patrice Gillespie Smith**, Urban Health Partnerships

## Appendix B: COMMUNITY RESOURCES

Broward Complete Streets Guidance Document and related Broward Complete Street Initiative information: [www.BrowardCompleteStreets.org](http://www.BrowardCompleteStreets.org)

Transforming Our Community Health Initiative: <http://www.touchbroward.org/>

Centers for Disease Control and Prevention Community Transformation Grant: <http://www.cdc.gov/communitytransformation/index.htm>

Model Design Manual for Living Streets: <http://www.modelstreetdesignmanual.com/>

## **Appendix C: ENDNOTES & PHOTO CREDITS**

1. Pages 17-19 – Workshop and Focus Groups Pictures, Patrice Gillespie-Smith
2. Page 28 - Appendix A Technical Advisory Committee Group Picture, Patrice Gillespie-Smith



**APPENDIX B:  
BROWARD COMPLETE STREETS INITIATIVE  
POLICY SCAN**



This page left blank intentionally.



Broward  
*Complete Streets*  
Initiative



POLICY SCAN  
*July 12, 2012*

*Safer, Healthier Streets for ALL Users*  
[www.BrowardCompleteStreets.org](http://www.BrowardCompleteStreets.org)



This publication was supported by the Cooperative Agreement Award Number U58DP003661-01 from the Centers of Disease Control and Prevention. Its contents are solely the responsibility of the authors and do not necessarily reflect the official views of the Centers of Disease Control and Prevention.

## ***Broward Complete Streets Initiative Policy Scan:***

In order to ensure Broward Complete Streets Guidelines are implemented throughout the County, it is critical to create a policy framework that helps cultivate an understanding and expedite the adoption of Complete Streets practices. Throughout the public engagement process for the Broward Complete Streets Initiative, residents articulated two steps as critical to realizing complete streets in their communities: 1) policies that enable and encourage a complete street approach to the design, construction and operation of local roads and 2) a shift in funding priorities that rewarded those projects that include complete streets elements.

Through a recently awarded Center for Disease Control and Prevention (CDC) grant, the Transforming Our Community's Health (TOUCH) Initiative, the Broward Regional Health Planning Council (BRHPC) asked partners, including the Broward MPO, Urban Health Partnerships and Smart Growth Partnership, to create healthy and safe places in Broward County that support active lifestyles. As the regional transportation planning agency for Broward County, the Broward MPO developed Complete Streets Guidelines for use by all local governments.

As local jurisdictions begin the process of adopting the Broward Complete Streets Guidelines, they should remember that they have the power to create safer, healthier streets in their communities. National research indicates that by accommodating all transportation modes and all users in street design, construction and operations, local governments can significantly decrease traffic-related accidents, build social capital, increase economic development, improve environmental settings and dramatically increase quality of life. With a balanced infrastructure in place, pedestrians, bicyclists and public transportation users are given a higher priority and thus will grow their prominence on our public rights-of-way. A successful policy will help a local jurisdiction achieve these improvements, thus it is beneficial for all stakeholders to spend time developing a comprehensive framework in the beginning of the process to help drive effective practices in the long-term.

When researching model policies, dozens of models were available for review, but this scan pulls from several key resources, including:

- National Complete Street Coalition's (NCSC) Website [www.completestreets.org](http://www.completestreets.org),
- American Planning Association's "[\*Complete Streets Best Policy and Implementation Practices\*](#)" and "[\*From Pavement to Policy\*](#)" documents
- National Policy and the Legal Analysis Network (NPLAN) to Prevent Childhood Obesity's "[\*Model Local Ordinance on Complete Streets\*](#)."

While the research on Complete Streets policies is voluminous, the Broward Complete Streets Initiative team was fortunate to also receive preliminary guidance by two instructors at a recent Complete Streets Policy workshop in the City of Deerfield Beach.

At the Deerfield Beach training, the NCSC consultants distributed the attached "[\*Elements of an Ideal Complete Streets Policy\*](#)" as its guide. In an attempt to help local governments adopt successful policies, NCSC offered the following list of critical ingredients:

1. Sets a vision.
2. Includes all modes.
3. Applies to both new and retrofit projects.
4. Emphasizes connectivity.
5. Applies to all phases of all applicable projects.
6. Specifies and limits exceptions, with management approval required.
7. Uses latest design guidelines, is flexible.
8. Is context-sensitive. (Smart Growth policies can help achieve this objective)
9. Sets performance standards.
10. Includes implementation steps.

As this Policy Scan was conducted, it was clear that there are many parts of the country that have conducted their own “best practices” scan, facilitating the identification of which polices and approaches have withstood the test of time. Rather than re-inventing the wheel, this Policy Scan takes the lessons learned from other best practices assessments and combines it with primary research.

Depending on a local jurisdiction’s Complete Streets Vision and the desires of its leadership, a spectrum of options to implement complete streets policies is available: 1) *pass a resolution* to indicate its support of complete streets (which serves as a precursor to policy change, but is not easily enforceable 2) *update the transportation element* in its comprehensive plan; 3) *update its street design manual* (which usually follows a resolution or an ordinance); 4) *pass an ordinance* directing changes within existing codes and standards and finally, 5) do all of the above *and* build in accountability measures that ensure a swift transition (by a multitude of local agencies) to complete streets practices. The San Diego Complete Streets Task Force developed the following matrix to show the pros and cons associated with the various approaches:

**Table 1: Types of Complete Street Policies: Pros and Cons of Various Policy Options**

Policy Type	Pros	Cons
City Council Resolution	<ul style="list-style-type: none"> <li>• Quick and easy, sets the vision.</li> </ul>	<ul style="list-style-type: none"> <li>• Not comprehensive, may lack specificity and leave priorities, standards, and procedures and performance measures unchanged.</li> </ul>
City Council Policy	<ul style="list-style-type: none"> <li>• Can include most of the elements of an ideal policy.</li> </ul>	<ul style="list-style-type: none"> <li>• Possibly involves more steps, requiring longer preparation.</li> <li>• Not integrated with other policies with which it may conflict.</li> </ul>
Ordinance	<ul style="list-style-type: none"> <li>• Implements the vision and provides specific standards and procedures; has the force of law.</li> </ul>	<ul style="list-style-type: none"> <li>• More steps, requiring longer preparation.</li> <li>• May not have adequate policy support.</li> </ul>

Internal Policy	<ul style="list-style-type: none"> <li>• Quicker implementation.</li> <li>• Required buy-in from affected agencies provides education opportunity across departments and disciplines.</li> </ul>	<ul style="list-style-type: none"> <li>• Not necessarily anchored in official policy.</li> <li>• May lack accountability mechanism such as performance measures and regular reports.(Dependent upon key personnel for execution.)</li> </ul>
General Plan Policy	<ul style="list-style-type: none"> <li>• Ideal policy vehicle for creating a Complete Streets policy and exceptions to Level of Service.</li> <li>• The GP is the jurisdiction’s “constitution”. All other policies, zoning, and regulations must be consistent with the GP.</li> </ul>	<ul style="list-style-type: none"> <li>• General plan amendments can require a lengthy process.</li> <li>• Must be followed up with specific implementation steps.</li> </ul>
Street Design Manual	<ul style="list-style-type: none"> <li>• Provides specific design guidelines allowing flexible options for complete street features.</li> </ul>	<ul style="list-style-type: none"> <li>• May lack necessary policy underpinning, including priorities, design flexibility, maintenance and operation details, performance measures, and a reporting requirement.</li> </ul>
Pedestrian/Bike Plans	<ul style="list-style-type: none"> <li>• Provide specific improvements and/or a framework for additional improvements.</li> </ul>	<ul style="list-style-type: none"> <li>• Tend not to provide guidance for balancing pedestrian or bicycle accommodations with those for other modes.</li> </ul>
Focused Plans  (Specific Plans, Corridor Plans, etc.)	<ul style="list-style-type: none"> <li>• Tailored to a particular geographic area and population.</li> <li>• Provide a pilot to test ideas.</li> <li>• Successful strategies can be adapted to other projects, but may require a design-exception approval process.</li> </ul>	<ul style="list-style-type: none"> <li>• Limits applicability to a small area.</li> <li>• May lack some key elements that apply to a citywide policy, such as flexibility and accountability.</li> </ul>

Adapted from: Table 3-1 Pros and Cons of Various Policy Options, [From Policy to Pavement: Implementing Complete Streets in the San Diego Region](#), San Diego Complete Streets Task Force, June 2012.

**Regional Policies:**

Representing 31 diverse jurisdictions, the Broward Metropolitan Planning Organization (MPO) is required to consider the broad needs presented by a range of local government agencies. In an attempt to capture these varying needs, this Policy Scan will first feature agencies, similar in structure to the Broward MPO, to identify successful examples where an MPO or a regional planning agency has developed a model for its member jurisdictions. Two examples were identified that seemed applicable to the Broward MPO’s efforts: the Sacramento Area Council of Governments (SACOG), and the Mid-

Ohio Regional Planning Council (MORPC). While these agencies had similar outcomes, they each took a different path, as outlined below:

- 1) **Sacramento Area Council of Governments (SACOG)** - In 2010, SACOG used the development of its 2035 [Metropolitan Transportation Plan](#) to express its support for Complete Streets. It “implemented a Community Design Funding Program that provides transportation dollars for Smart Growth developments that promote walking, bicycling and transit use. The plan also includes a Complete Streets strategy that provides technical guidance to local agencies and invests regional funds to build complete streets projects through designated and planned community activity centers. This ensured bicycles, pedestrians, and transit can share the road safely and compatibly with autos. Finally, the plan calls for equity funding for the maintenance of complete streets.” (Analysis taken from the [Maricopa Association of Governments Regional Council Complete Streets Guide, April 2011](#))

To facilitate ongoing commitment and accountability, SACOG also established a “Complete Streets Coalition of Sacramento” that meets on a regular basis and offers guidance for walkability audits. By tying its federal funds to complete streets, SACOG employed an important incentive available to MPOs across the country. This approach could be adopted by the Broward MPO as it prepares to begin its 2040 Long Range Transportation Plan (LRTP). While Complete Streets is mentioned in the 2035 LRTP, the Broward MPO may want to take steps to specifically incorporate the Broward Complete Streets Guidelines into the 2040 LRTP. Furthermore, it may want to consider developing its own Complete Streets Coalition or Task Force, as several TAC members have indicated a desire to continue working on the Broward Complete Streets Initiative to ensure the implementation of the Guidelines.

- 2) **Mid-Ohio Regional Planning Council (MORPC)** - Using a more incremental approach, MORPC first adopted a [Complete Streets Policy](#) in April 2010. As a result, two member municipalities have adopted the Complete Streets policy and two other cities are in the process of adopting a similar policy. To support its regional policy it developed a “[Complete Streets Checklist](#)” as a way of encouraging its members to pursue Complete Streets elements when applying for federal transportation dollars. While this checklist is comprehensive in its review of candidate projects, it is so detailed that technical assistance may be required to answer some of the questions. As follow up, it developed a [Complete Streets Toolkit](#) this month, which is comparable to the Broward Complete Streets Guidelines.

Should the Broward MPO want to take a similar path, it could develop a Complete Streets Checklist to reinforce the importance of Complete Streets with its members. The checklist is a type of performance measure which clearly outlines ways a local jurisdiction could incorporate Complete Streets elements into its transportation priorities. The toolkit is a more in-depth resource that, like the Broward Complete Street Guidelines, helps transportation professionals understand how to incorporate these new standards into their existing codes and regulations.

## ***Municipal Policies:***

The intent of the Broward Complete Streets Guidelines is to help facilitate the implementation of Complete Streets in Broward's 31 municipalities. Thus, this analysis also provides an overview of the broad range of implementation strategies other cities have used across the country.

Seattle, WA provides an example of an ordinance that includes broad directives and relies on the appropriate agencies for the specifics. Passed in 2007, [the ordinance](#) "directs the city's transportation department to implement Complete Streets in construction of all new streets and the retrofitting of existing streets." With this general direction, the Seattle Department of Transportation and the Department of Planning and Design were given the latitude to develop their own design guidelines. The Seattle Department of Transportation ultimately updated its [Right of Way Improvements Manual](#) to reflect the changes. This manual sends a strong message to all users of the street and instructs both private developers and public agencies how to design future corridors to accommodate all users.

Because the updating of the *Right Of Way Improvements Manual* was intensive lengthy process, management developed an internal policy to immediately seek Complete Streets elements wherever practicable and that it must have a written explanation of where it would be unable to produce a Complete Street on a resurfacing or construction project.

On the opposite end of the spectrum, the City of Charlotte started first with its [Urban Street Design Guidelines](#) (USDG) and included policy elements within the guidelines, stating, "By adopting the document entitled the USDG, the City Council declares that the Guidelines are the policy of the City of Charlotte." The document then lists the 12 steps the City of Charlotte is taking to adopt and implement Complete Streets. While this appears to be an efficient form of implementing the guidelines, behind-the-scenes work will be necessary to help staff understand the shift away from existing policies and into the new guidelines.

In an attempt to change the culture of an entire city, New York City released the ["Sustainable Streets" Strategic Plan](#) in Spring 2008. In this bold plan, it outlined very specific goals to achieve a more sustainable transportation system, with the overall mission of "Making the Nation's Safest Big City Even Safer." By including a comprehensive listing of its existing traffic statistics and audacious goals of changing not only the department's behaviors, but those of the traveling public, the NY Department of Transportation executed a targeted approach to a broad problem. In the end, the Sustainable Streets Strategic Plan probably increased buy-in dramatically by creating a readable document with the promise of measuring progress. Demonstrating their commitment to accountability, the Mayor and the Director of the New York Department of Transportation reported the Department's success to the public one year after the adoption of Sustainable Streets. While this method of introducing Complete Streets may be time intensive and heavily dependent upon the city's administration, it is a transparent method of bringing the public with you every step of the way.

In Florida, jurisdictions have taken a range of approaches to introduce the concept of Complete Streets to its public officials and residents. In 2010, West Palm Beach updated the [Transportation Element](#) of its Comprehensive Plan. It first identified Complete Streets in the principles of its vision:

**“Develop Complete Streets:** The City shall promote the development of “Complete Streets” that are designed, built, and maintained in a manner that accommodates not only automobiles, but transit vehicles and non-motorized modes of travel such as pedestrians and bicyclists. “Complete Streets” shall seek to be aesthetically pleasing and provide for a comfortable environment for its different users.”

The Comprehensive Plan subsequently identified supportive policies that could help advance the implementation of Complete Streets. The update also includes some right-of-way set back standards, for specific streets and other mandates that will help advance Complete Street elements.

By inserting Complete Streets in a municipality’s Comprehensive Plan, a municipality empowers staff to reference that “it’s in the Comp Plan” when new projects are brought before the Planning and Zoning commissions or other agencies for review. Unfortunately, this broader approach sometimes leaves room for interpretation and thus can be challenging to enforce.

Despite this diverse array of implementing Complete Streets, the first step every local jurisdiction can begin with is adopting a resolution. Last year, Winter Park, Florida adopted a [4 page resolution](#) not only stating why it was supportive of Complete Streets, but also outlining impacted policies and practices. Resolutions are an effective way of establishing a Vision with leaders and constituents and sending a message that a City intends to change its policies and practices. Because resolutions are non-binding, they can serve as a tool that can be used when a local jurisdiction isn’t sure how others might receive a newer concept like Complete Streets. On the other hand, ordinances, because they are enforceable, carry more weight, but also can require more work to get passed.

In Broward, municipalities have a great opportunity through the Transforming Our Community’s Health (TOUCH) grant focused on the adoption of Smart Growth policies. The Smart Growth Partnership is currently providing technical assistance to numerous cities in Broward County to help them realize “Smart Codes.” These policies support walkable, livable communities with mixed-use development and Complete Streets Guidelines. Municipalities pursuing Smart Growth policies should consider using this effort as a way of incorporating Complete Streets policies into their codes.

By way of example, the City of Deerfield Beach and the City of North Lauderdale have taken this route by coupling the Smart Growth and Complete Street initiatives. Recently both cities passed resolutions ([City of Deerfield Resolution 2011/184](#) and [North Lauderdale Resolution March 2012](#)) that stated their intent to pursue both Smart Growth and Complete Street policies. West Park and Pompano Beach also have adopted resolutions in support of smart growth policies that include developing Complete Streets. By September 2012, the Smart Growth Partnership will have worked with more than one third of

Broward’s municipalities to make a commitment, by resolution, to support smart growth principles, which will further the next steps needed in implementing the Complete Street Guidelines. Furthermore, the City of Deerfield Beach has taken the next step in advancing Complete Street Guidelines by developing an interdepartmental team that meets monthly to plan for the adoption of the Complete Street Guidelines into its Comprehensive Plan and Engineering Standards.

### ***County Policies:***

Similarly, Martin County, FL also updated its [Comprehensive Plan in 2010](#) to reflect its desire to have Complete Streets:

“Policy 5.2A.14. Promote ‘Complete Streets’ to the extent feasible, the County shall promote and implement the concept of ‘Complete Streets’ that accommodate all users, including motorized vehicles, bicyclists, public transportation vehicles and riders, and pedestrians of all ages and abilities.”

Since Martin County’s Comprehensive Plan was updated to include Complete Streets, it has recently issued several promotional videos to encourage Complete Streets concepts to its residents. Counties contemplating this first step may want to consider a follow-up ordinance or update in the County’s street design manual to help provide more guidance to those developing near or designing; constructing; and operating in county corridors.

Locally, Broward County adopted the: [Alternative Roadway Design Plan in 2008](#) which encouraged a shift from autocentric design to one that is more pedestrian and bicycle friendly. While the document does not specifically mention Complete Streets, it references numerous related concepts. If Broward County has received significant buy-in to these new design guidelines, it may want to consider trying to merge the new Broward Complete Streets Guidelines with the existing Alternative Roadway Design Plan. By building on the foundation established by the Alternative Guidelines, staff and consultants can incrementally incorporate the Complete Streets Guidelines into their policies and practices.

Another relevant County document, the 2007 [Countywide Community Design Guidebook](#), states:

“The greatest potential for realizing the community goal of improving the overall quality of life in Broward County lies in connecting transportation with actual land use, and acknowledging that the key functions of the transportation corridor should include:”

- providing public space for wayfinding and exchange
- providing access to properties and land
- providing a route for multiple modes of transportation
- providing infrastructure for supporting services and utilities

From both documents, it is evident the County is placing a greater emphasis on alternative modes of transportation. The emphasis on Smart Growth concepts as they relate to the public right of way is

encouraging: complementary land use is critical to the success of any Complete Street. However, the County will want to reconcile the Guidelines with these previous efforts.

One approach that Broward County may consider was used by Lee County, FL, who formed a Complete Streets Interdepartmental team in 2010 and tasked it with updating its Comp Plan and preparing for the adoption of Complete Streets Guidelines. Citing the US Complete Streets Act of 2009, this interdepartmental team was responsible for saving the County \$58.5 million by reprogramming five road-widening projects approved in the 2035 Long Range Transportation Plan. Each was slated for four lanes, but was scaled back to two lanes with median and turn lanes, and cycling and walking facilities. (National Complete Streets Coalition, [Costs of Complete Streets: What We are Learning from State and Local Governments](#)). It should be noted that Lee County is in the process of adopting Complete Streets and is looking to the Broward Complete Street Guidelines as a potential tool for its municipalities.

At the regional level, the Broward MPO can provide a catalyst for local jurisdictions to begin considering Complete Streets guidelines by changing its current review process for competitive grants to include a priority ranking for projects that include Complete Streets Initiative. It is through this financial incentive that local jurisdictions will see the merits of quickly incorporating Complete Streets elements.

### ***A Proposed Road Map to Adopting Complete Streets in Your Community***

While several approaches were reviewed in this analysis, there is no silver bullet to implementation; rather, success lies in a multi-step, incremental approach. As mentioned above, any Complete Streets policy will be bolstered by incorporating land use considerations into its vision. The path below outlines steps, not content, to consider when implementing Complete Streets. Many resources cited in this Policy Scan provide model language for consideration when drafting a policy.

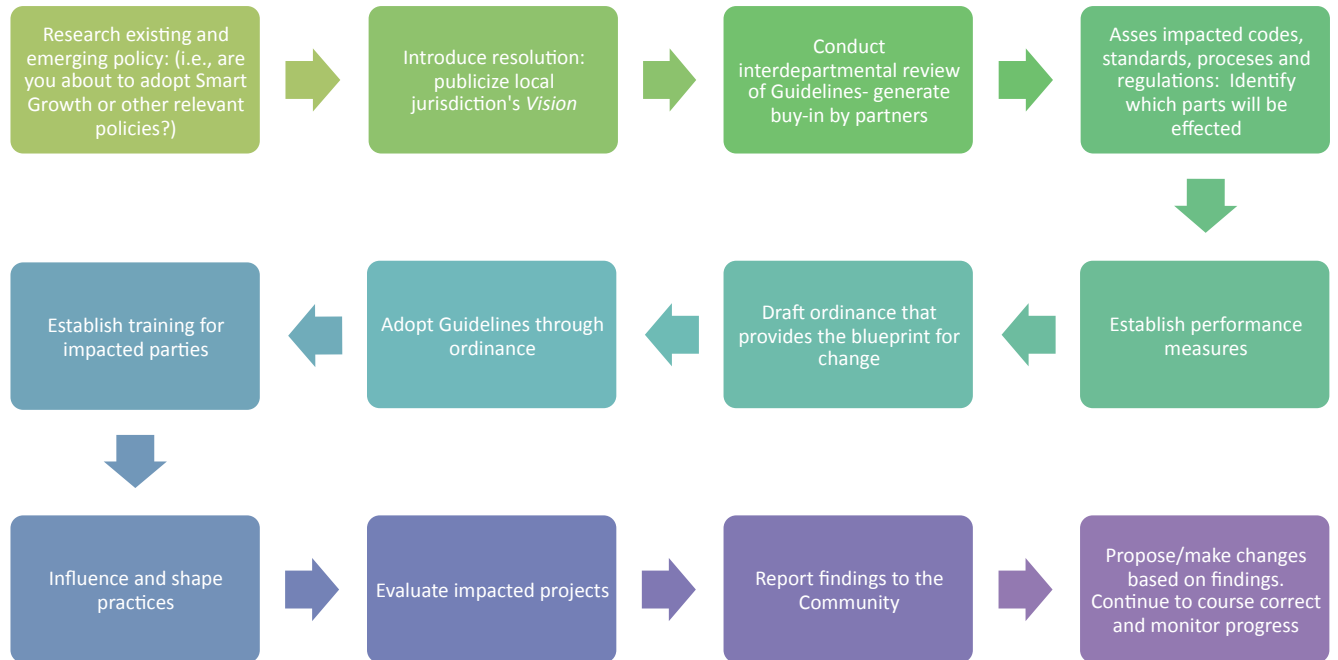

While this flow chart exemplifies the ideal path to achieving Complete Streets in one's community, it is understood that various jurisdictions may choose a different route due to mitigating circumstances. In this instance, it is recommended to anchor back to the *Vision* or resolution in each step that the local jurisdiction takes. The step of continually reminding your stakeholders of the *Vision* will help them understand why changes are necessary. Painting a *Vision* reminds partners and constituents that the short-term inconvenience of changing standards, code or regulations will have a long-term payoff for the entire community. Equally important to the *Vision* is a local jurisdiction's willingness to evaluate and report its findings to the community. A county or a municipality will want to be armed with data about the impact of the Complete Streets improvements rather than relying on anecdotes. Data should include safety and health measurements that include physical activity and crash statistics. To find sample language for a municipal Complete Streets ordinance, readers are encouraged to read National Policy & Legal Analysis Network's (NPLAN) ["Model Local Ordinance on Complete Streets."](#)

In conclusion, it is clear that depending on a jurisdiction's goals and objectives, the path to achieving Complete Streets will vary. The Broward MPO has the ability to provide the foundation for Complete Streets policies and the incentives to warrant the implementation of Complete Streets. However, it will be up to the local government to take the appropriate steps to change its current and future practices to accommodate all modes of transportation for users of all ages and abilities. If local jurisdictions want to expedite the implementation of Complete Streets, they will want to choose a path that is enforceable, but also that includes incentives for buy-in. Establishing a *Vision* is a great start, but may not be realized if it is left as a standalone document.

Interested parties are encouraged to review the highlighted sources in this document, which can be accessed by clicking on the blue links within the report; a list of resources is also available at the end of this document.

## Resources:

- National Complete Streets Coalition. *National Complete Street Coalition Website*. Available at: [www.completestreets.org](http://www.completestreets.org)
- National Complete Streets Coalition. *Complete Streets Atlas*. Available at: <http://www.completestreets.org/complete-streets-fundamentals/complete-streets-atlas/>
- American Planning Association. *Complete Streets Best Policy and Implementation Practices*. Available at: <http://urbanhs.com/wp-content/uploads/2012/06/Best-CS-Policy-and-Implementation-Practices.pdf>
- American Planning Association California Chapter. *From Pavement to Policy*. Available at: [http://sdapa.org/go/wp-content/uploads/2012/03/Policy\\_to\\_Pavement\\_low\\_res.pdf](http://sdapa.org/go/wp-content/uploads/2012/03/Policy_to_Pavement_low_res.pdf)
- American Planning Association. *National Policy*. Available at: [www.planning.org](http://www.planning.org)
- Legal Analysis Network to Prevent Childhood Obesity (NPLAN). *Model Local Ordinance on Complete Streets*. Available at: [https://docs.google.com/document/d/1Ny5x8AGZQ3bAmWX\\_N490kH-LxJlF5EnDQP5UCQ0Bw/preview?pli=1](https://docs.google.com/document/d/1Ny5x8AGZQ3bAmWX_N490kH-LxJlF5EnDQP5UCQ0Bw/preview?pli=1)
- National Complete Streets Coalition. *Elements of an Ideal Complete Streets Policy*. Available at: <http://www.completestreets.org/webdocs/policy/cs-policyelements.pdf>
- San Diego Complete Streets Task Force. (2012, June). *From Policy to Pavement: Implementing Complete Streets in the San Diego Region*. [http://sdapa.org/go/wp-content/uploads/2012/03/Policy\\_to\\_Pavement\\_low\\_res.pdf](http://sdapa.org/go/wp-content/uploads/2012/03/Policy_to_Pavement_low_res.pdf)
- Sacramento Area Council of Governments (SACOG). *Complete Streets Technical Assistance Tools*. Available at: [http://urbanhs.com/wp-content/uploads/2012/06/sacog\\_complete-streets-wkshop\\_07102009\\_bg.pdf](http://urbanhs.com/wp-content/uploads/2012/06/sacog_complete-streets-wkshop_07102009_bg.pdf)
- Sacramento Area Council of Governments (SACOG). (2010). *Chapter 5: Policies and Supportive Strategies. Metropolitan Transportation Plan*. Available at: <http://urbanhs.com/wp-content/uploads/2012/06/SACOG05-Policies-and-Supportive-Strategies.pdf>
- Maricopa Association of Governments Regional Council (2011, April). *Complete Streets Guide*. Available at: [http://www.azmag.gov/Documents/BaP\\_2011-01-25\\_MAG-Complete-Streets-Guide-December-2010.pdf](http://www.azmag.gov/Documents/BaP_2011-01-25_MAG-Complete-Streets-Guide-December-2010.pdf)

- Mid-Ohio Regional Planning Council (MORPC). *Complete Streets policy*. Available at: [http://www.morpc.org/trans/CompleteStreets\\_MORPC\\_CS\\_PolicyFINAL2010-03-31.pdf](http://www.morpc.org/trans/CompleteStreets_MORPC_CS_PolicyFINAL2010-03-31.pdf)
- Mid-Ohio Regional Planning Council (MORPC). (2011). *Complete Streets Checklist*. Available at: [http://www.morpc.org/trans/CompleteStreets\\_MORPC\\_CS\\_ChecklistFINAL2010-03-31WithAppendices.pdf](http://www.morpc.org/trans/CompleteStreets_MORPC_CS_ChecklistFINAL2010-03-31WithAppendices.pdf)
- Mid-Ohio Regional Planning Council (MORPC). (2011). *Complete Streets Toolkit*. Available at: [http://www.morpc.org/trans/CS\\_Toolkit\\_Web\\_Lo\\_Res.pdf](http://www.morpc.org/trans/CS_Toolkit_Web_Lo_Res.pdf)
- City of Seattle, Legislative Department. *Ordinance 122386*. Available at: [http://clerk.ci.seattle.wa.us/~archives/Ordinances/Ord\\_122386.pdf](http://clerk.ci.seattle.wa.us/~archives/Ordinances/Ord_122386.pdf)
- Seattle Department of Transportation. *Right of Way Improvements Manual*. Available at: <http://www.seattle.gov/transportation/rowmanual/>
- City of Charlotte. *Urban Street Design Guidelines*. Available at: [http://charmeck.org/city/charlotte/Transportation/PlansProjects/Documents/USDG\\_Full\\_Document\\_small.pdf](http://charmeck.org/city/charlotte/Transportation/PlansProjects/Documents/USDG_Full_Document_small.pdf)
- New York City. (2008). *"Sustainable Streets" strategic plan*. Available at: [http://www.nyc.gov/html/dot/downloads/pdf/stratplan\\_compplan.pdf](http://www.nyc.gov/html/dot/downloads/pdf/stratplan_compplan.pdf)
- West Palm Beach. (2010). *Transportation Element*. Available at: [http://www.cityofwpb.com/plan/CompPlan/3\\_Transportation\\_Element\\_Final.pdf](http://www.cityofwpb.com/plan/CompPlan/3_Transportation_Element_Final.pdf)
- Winter Park, Florida. *Resolution 2083-11*. Available at: <https://www.cityofwinterpark.org/Docs/Government/ordinances/2083-11.pdf>
- City of Deerfield Beach. (2011, October). *Resolution No. 2011/184*. Available at: <http://urbanhs.com/wp-content/uploads/2012/07/Smart-Growth-Assistance-Resolution.pdf>
- City of North Lauderdale. (2012, March). *Resolution Supporting Smart Growth and Complete Street Principles*. Available at: [http://urbanhs.com/wp-content/uploads/2012/07/northlauderdaleRESO\\_Smart\\_Growth.pdf](http://urbanhs.com/wp-content/uploads/2012/07/northlauderdaleRESO_Smart_Growth.pdf)
- Martin County, Florida. *Comprehensive Plan in 2010*. Available at: <http://library.municode.com/index.aspx?clientId=13591>
- Broward County. (2008). *Alternative Roadway Design Plan in 2008*. Available at: <http://urbanhs.com/wp-content/uploads/2012/06/BC-Design-Guidelines.pdf>

- Broward County. (2007). *Countywide Community Design Guidebook*. Available at: <http://www.broward.org/PlanningAndRedevelopment/DemographicsAndEconomics/Pages/UrbanDesign.aspx>
- National Complete Streets Coalition. *Costs of Complete Streets: What we are Learning from State and Local Governments*. Available at: <http://completestreets.org/webdocs/factsheets/cs-costs-2.pdf>



# **APPENDIX C: SMART GROWTH MODEL RESOLUTION**





This page left blank intentionally.

**TO: Mayor and City Commission**

**FROM:**

**BY:**

**DATE:**

**SUBJECT: Resolution Supporting Smart Growth Principles**

Tonight we are requesting the City Commission's consideration of adopting the attached Resolution supporting Smart Growth Principles and a motion authorizing the submission of a request for technical assistance to the Smart Growth Partnership Organization.

**Background:**

The Smart Growth Public Infrastructure Policy Act was passed in 2010 requiring State agencies to consider smart growth criteria when evaluating public infrastructure projects. Smart growth practices promote economic growth and reinvestment in developed and developing areas, while preserving open space and protecting natural resources. Development decisions affect many of the things that touch people's everyday lives - their homes, their health, the schools their children attend, the taxes they pay, their daily commute, the natural environment around them, economic growth in their community, and opportunities to achieve their dreams and goals. What, where, and how communities build will affect our residents' lives for generations to come

Smart growth values long-range, regional considerations of sustainability over a short-term focus. Its goals are to achieve a unique sense of community and place; expand the range of transportation through a mix of transit, walking and bicycle-friendly land use, employment, and housing choices; equitably distribute the costs and benefits of development; preserve and enhance natural and cultural resources; and promote public health. As \_\_\_\_\_ undertakes redevelopment, we encourage the City to adopt these principles and utilize them during the review of development applications. Administration requests Commission's consideration of the attached Resolution that endorses the City's support of Smart Growth Principles.

The City was awarded technical assistance from the Smart Growth Partnership organization to: educate staff and the community regarding smart growth policies, audit the city's existing policies and the Smart Growth Partnership will provide policies for the City to consider adding, amending to meet Smart Growth Principles.

**Recommendation:**

At this time, Administration recommends that the City Commission adopt the attached Resolution and authorize the City Manager, or her designee, and City Clerk to forward the Resolution to the Smart Growth Partnership Organization.

The above language is meant to help support the adoption of the resolution. Fill in the "city" name. Also, if the city has accomplished any smart growth initiatives, it would be helpful to add this to your memorandum. The background information, first paragraph comes from the EPA's Office of Sustainable Communities, smart growth background. Additional, facts, and information can be located [http://www.epa.gov/dced/about\\_sg.htm](http://www.epa.gov/dced/about_sg.htm) and [www.smartgrowthamerica.org](http://www.smartgrowthamerica.org), [www.smartgrowthpartnership.org](http://www.smartgrowthpartnership.org). Smart Growth Partnership, also developed a "what is smart growth" FQ sheet that can also be provided

**RESOLUTION NO. \_\_\_\_\_**

**A RESOLUTION OF THE CITY COMMISSION OF THE CITY OF \_\_\_\_\_, FLORIDA, EXPRESSING COMMITMENT WHICH FOSTERS A UNIQUE IDENTIFY FOR \_\_\_\_\_ AND INCPORATES THE PRINCIPLES OF SMART GROWTH AND EXPRESSING SUPPORT OF THE SMART GROWTH PARTNERSHIP’S TECHNICAL ASSISTANCE AND STRIVES TO IMPLEMENT SMART GROWTH STRATEGIES THAT ENHANCE AND STRENGTH, AND SUPPORT THE LONG TERM HEALTH OF THE COMMUNITY.**

**WHEREAS**, the City \_\_\_\_\_ wishes to create a fiscally healthy and sustainable community through the evaluation and implementation of Smart Growth principles; and

**WHEREAS**, the term “smart growth” roots in planning and transportation that concentrates growth to avoid urban sprawl and advocates compact, transit-oriented, walkable, bicycle-friendly land use, including neighborhood schools, mixed-use development with a range of housing choices appropriate for the context of the City; and

**WHEREAS**, the City \_\_\_\_\_ has already shown commitment to these principles by applying for and receiving Smart Growth Partnership’s technical assistance grant to evaluate and educate the City on Smart Growth techniques that strive to strengthen and improve the health of its citizenry and community;

**WHEREAS**, the City of \_\_\_\_\_ wishes to continue the momentum created from the technical assistance’s suggested next steps for the City to incorporate smart growth principles;

**NOW, THEREFORE, BE IT RESOLVED BY THE CITY COMMISSION OF THE CITY OF XX, FLORIDA, AS FOLLOWS:**

Section 1: The foregoing recitals contained in the preamble to this Resolution are incorporated by reference herein.

Section 2: The City Commission will strive to continue the effort to adopt, enforce, and educate property owners about land-use policies that reduce sprawl, preserve open space and create compact, walk able urban communities while promoting transportation options such as bicycle trails, commute trip reduction programs, opportunities for car pooling and public transit.

Section 3: The Commission members, in their roles as local government leaders, consider the relationship between decisions made today and their long-term impacts, and recognize that our success as community leaders is dependent on an open decision-making process that takes into account the long-term economic, environmental, health and social well-being of our communities well into the next century.

PASSED AND ADOPTED by the City Commission of the City \_\_\_\_\_, Florida, this \_\_\_\_\_ day of \_\_\_\_\_.

## APPENDIX D: VISIONS OF TRANSFORMING STREETS

The photo-simulations in Appendix D present images of how streets can be changed to make better places and neighborhoods. The simulations show the application of principles and concepts described throughout this manual.





Credit: Todd Clements

*Note: Use of red colored pavement within the bicycle lane is a decorative treatment and is not considered a traffic control device. See Chapter 9 for information on the use of green colored pavement for bike lanes.*



*Credit: Dan Burden*

APPENDIX D: VISIONS OF TRANSFORMING STREETS



Credit: Alexis Lantz

APPENDIX D: VISIONS OF TRANSFORMING STREETS



Credit: Marty Bruinsma



*(Credit: Marty Bruinsma)*



(Credit: Marty Bruinsma)



This page left blank intentionally.



## APPENDIX E: HELPFUL LINKS

Broward Complete Streets Initiative

<http://urbanhs.com/initiatives/completestreets/>

Broward Regional Health Planning Council (BRHPC)

<http://www.brhpc.org/>

Broward Metropolitan Planning Organization (MPO)

<http://www.browardmpo.org/>

Smart Growth Partnership

<http://www.smartgrowthpartnership.org/>

National Complete Streets Coalition

<http://www.completestreets.org/>

National Center for Safe Routes to School

<http://www.saferoutesinfo.org/>

Federal Highway Administration (FHWA), *Manual on Uniform Traffic Control Devices for Streets and Highways* (MUTCD), 2009 Edition with Revisions 1 and 2, 2012.

[http://mutcd.fhwa.dot.gov/kno\\_2009r1r2.htm](http://mutcd.fhwa.dot.gov/kno_2009r1r2.htm)

Institute of Transportation Engineers. *Designing Walkable Urban Thoroughfares: A Context Sensitive Approach*, 2010.

<http://www.ite.org/emodules/scriptcontent/orders/ProductDetail.cfm?pc=RP-036A-E>

National Association of City Transportation Officials (NACTO), *Urban Bikeway Design Guide*, 2011.

<http://nacto.org/cities-for-cycling/design-guide/>

Florida Department of Transportation (FDOT) *Manual of Uniform Minimum Standards for Design, Construction, and Maintenance for Streets and Highways* (The Florida Greenbook), 2011.

<http://www.dot.state.fl.us/rddesign/FloridaGreenbook/FloridaGreenbook.pdf>

Florida Department of Transportation (FDOT), *2012 Plans Preparation Manual*.

<http://www.dot.state.fl.us/rddesign/PPMManual/2012/Volume1/2012Vol1.shtm>

Charlotte-Mecklenburg County Urban Street Design Guidelines – Glossary of Terms

<http://charmeck.org/city/charlotte/Transportation/PlansProjects/Documents/RevUSDGChapter6KHO23.pdf>